



THE HARD WORKING PUMP

The result of superior technology and expertise that has stood the test of time.



END SUCTION CHEMICAL & PROCESS PUMPS **TEC** - SERIES

50 Hz

C O N T E N T S

END SUCTION CHEMICAL & PROCESS PUMPS (ANSI/ASME B73.1) TEC SERIES (50Hz)

	Page No.
Model Identification Code & Materials of Construction	4
Description, Key Features, Applications & Technical Specifications	5
General Pump Selection & Operation Instructions	6
Exploded View	7
Cross Sectional Drawing	8
Performance Curves	9-44
Interchangeability Chart	45-46
Details of Standard Components	47
Bare Shaft Pump - Mounting Dimensions	48

END SUCTION LIGHT CHEMICAL & PROCESS LOW FLOW PUMPS TEC - IL SERIES (50Hz)

	Page No.
Description, Key Features, Applications & Technical Specifications	49
Exploded View	50
Cross Sectional Drawing	51
Performance Curves	52-61
Interchangeability Chart	62
Bare Shaft Pump - Mounting Dimensions	63
Overall Range & Performance Details	64

GENERAL DATA

Model Identification Code

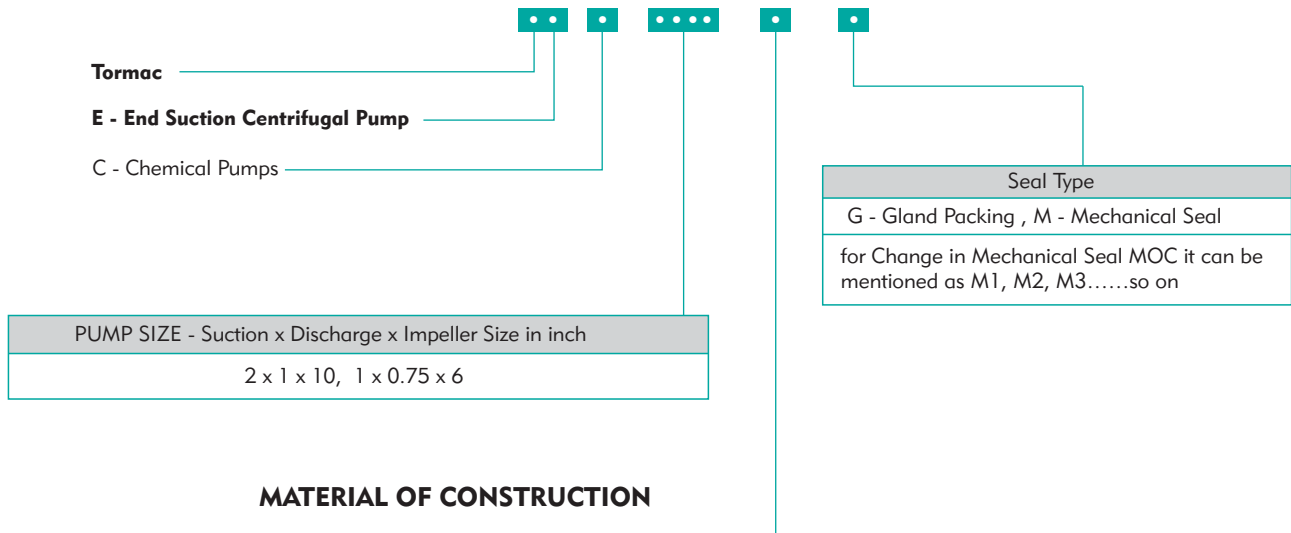

MATERIAL OF CONSTRUCTION

TYPE S

Parts Name	Material	EUROPEAN	DIN	SAE/AISI
Casing & Stuffing Box	CF 8	X5CrNi18-9	1.4308	ASTM A743 / A351 CF8
Impeller	CF 8	X5CrNi18-9	1.4308	ASTM A743 / A351 CF8
GLAND	CF 8	X5CrNi18-9	1.4308	ASTM A743 / A351 CF8
Shaft	SS 316	X5CrNiMo 18 10	1.4401	ASTM A276 AISI 316
Shaft Sleeve	SS 316	X5CrNiMo 18 10	1.4401	ASTM A276 AISI 316
Bearing Housing & Connecting Frame	Cast Iron	EN-GJL-220	(0.6020) GG20	ASTM A48 class 30B

TYPE N

Parts Name	Material	EUROPEAN	DIN	SAE/AISI
Casing & Stuffing Box	SS 316	X6CrNiMo 18 10	1.4408	ASTM A743 / A351 CF8M
Impeller	SS 316	X6CrNiMo 18 10	1.4408	ASTM A743 / A351 CF8M
GLAND	SS 316	X6CrNiMo 18 10	1.4408	ASTM A743 / A351 CF8M
Shaft	SS 316	X5CrNiMo 18 10	1.4401	ASTM A276 AISI 316
Shaft Sleeve	SS 316	X5CrNiMo 18 10	1.4401	ASTM A276 AISI 316
Bearing Housing & Connecting Frame	Cast Iron	EN-GJL-220	(0.6020) GG20	ASTM A48 class 30B

General Instructions

- Performance curves are as per specific gravity and viscosity of water.
- Performance curve tolerances are as per HI : 14.6 / ISO: 9906, Grade 2B
- For Safety consider a margin of 0.5m higher of NPSH.
- All dimensions are in mm

END SUCTION CHEMICAL & PROCESS PUMPS > TEC - SERIES (ANSI/ASME B73.1)

The TEC series of chemical and process pumps are horizontal, end-suction, single-stage pumps designed for reliability and safety. These pumps meet ASME (ANSI) B73.1 standards for dimensional, configuration, and design features, ensuring ease of installation. They feature a semi-open scallop-cut impeller that is ideal for pumping low-viscosity fluids with suspended solids. This impeller design also simplifies cleaning and maintenance. The TEC series offers a variety of material options to suit different applications, and a cooling jacket is available for processes requiring temperature control to maintain optimal pumping performance.

Technical data

Head Range	5 - 154.5m
Flow Range	5 - 860m ³ /h
Speed	1450 / 2900 rpm
Impeller Type	Semi Open Impeller
Outlet Size	1" - 8"
Power Range	0.55 - 93kW
Maximum Liquid Temperature	-20°C to 140°C Optional : Cooling Jacket models max. 260°C
Shaft Seal	Standard : Gland Packing
	Optional : Mechanical Seal
Bearing Lubrication	Oil
Flange Standard	ASME 16.5 Class 150
Maximum working Pressure	8-16 bar



Applications

- Chemical processing
- Erosive / Corrosive Liquors
- Chemical dosing and injection
- Demineralized Water
- Condensate Water
- Acid Transfer
- Distilled liquid transfer
- Brine Transfer
- Pharmaceutical
- Process liquids with suspended solids
- Solvent transfer

Design Features

- Back Pull-out Design for ease of maintenance
- High Efficiency & optimized performance
reduces the operating Cost
- Robust shaft and bearing design
- Non clog impeller
- Modular design helps reduce spare parts
inventory

Note: The company reserves the right to modify the technical specifications and illustrations without prior notice.

GENERAL PUMP SELECTION & OPERATION INSTRUCTIONS

1. All performance curves are based on water (specific gravity = 1.0; low viscosity). Corrections must be applied for fluids with different properties.
2. Select a motor or engine with sufficient power margin above the pump duty point. This prevents overloading under normal and transient operating conditions.
3. Always calculate NPSHA (Net Positive Suction Head Available) carefully, especially when pumping hot or cold liquids with negative or positive suction. Account for vapor pressure effects.
4. Ensure $NPSHA \geq NPSHR + 0.5m$ to avoid cavitation during both negative and positive suction conditions.
5. For high-viscosity fluids, apply viscosity correction factors to head, flow and efficiency.
6. Choose pumps to operate within 70% to 120% of the Best Efficiency Point (BEP) against flow. Operating within this range ensures better efficiency, reliability, and reduced wear.
7. Select pump materials based on fluid properties:
 - i. Chemical compatibility
 - ii. Operating temperature
 - iii. Abrasiveness or corrosiveness
8. Use suction and discharge piping at least one nominal size larger than the pump nozzle to reduce friction losses and turbulence.
9. Delivery Side:
 - i. Install a Non-Return Valve (NRV) to prevent backflow.
 - ii. Install a gate or globe valve to control flow during start-up/shutdown.
10. Start-Up and Shut-Down Procedure:
 - i. Keep the delivery valve closed when starting or stopping the pump.
 - ii. For mixed flow pumps and pumps with a rising power curve toward shut-off, the pump must be started and stopped with the delivery valve in the open position, or as per the manufacturer's specific recommendations.
11. All pump performance curve tolerances conform to HI : 14.6 / ISO : 9906 Grade 2B standards.

EXPLODED VIEW

GLAND PACKING CONSTRUCTION

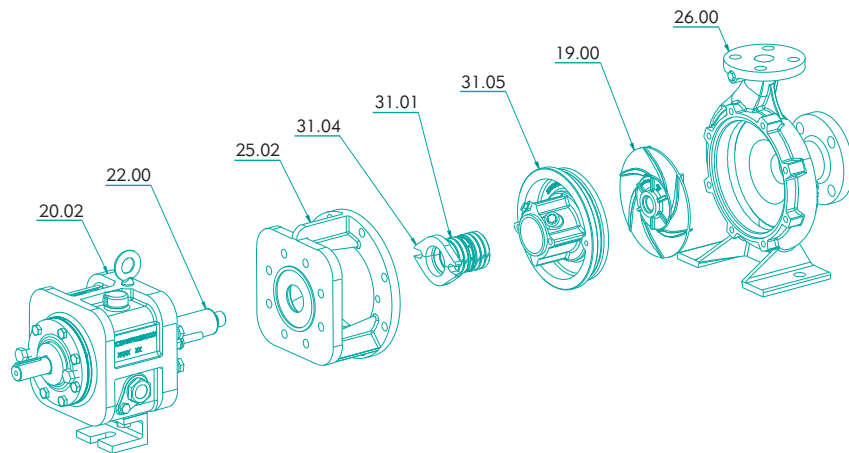

MECHANICAL SEAL CONSTRUCTION

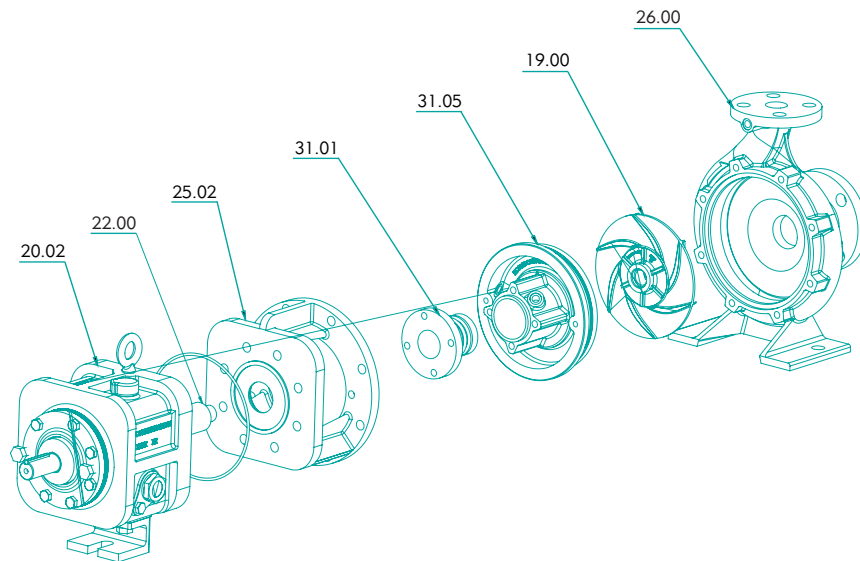

PART NO	PART NAME
26.00	Casing
19.00	Impeller
31.05	Stuffing Box
31.01	Gland Packing / Mechanical Seal
25.02	Connecting Frame
20.02	Bearing Frame
22.00	Pump Shaft
31.04	Gland

CROSS SECTIONAL DRAWING

GLAND PACKING CONSTRUCTION

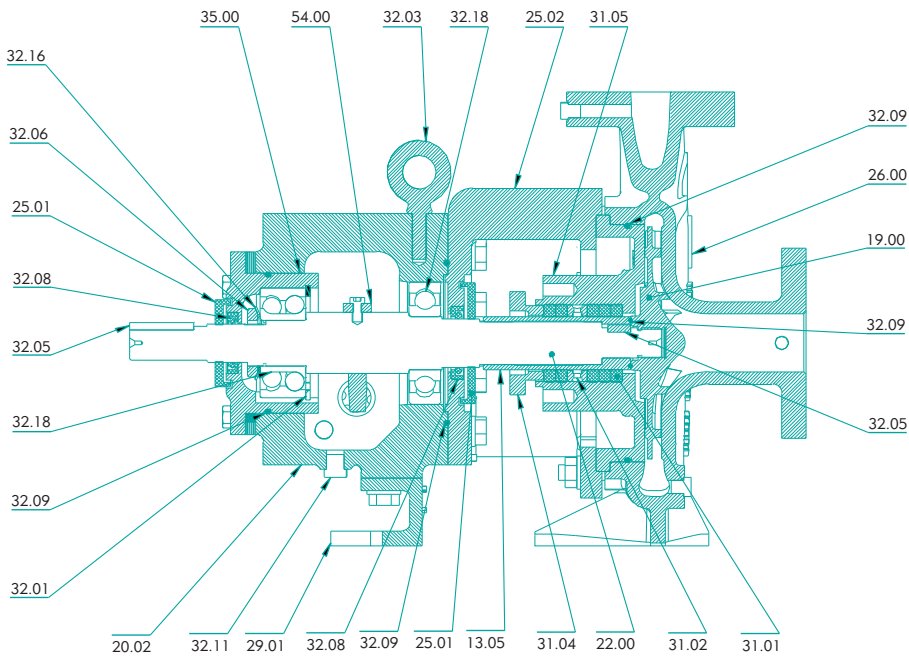

PART NO	PART NAME
32.11	Plug
20.02	Bearing Frame
32.01	Circlip
32.18	Bearing
32.06	Lock Nut
32.16	Washer
35.00	Bearing Housing
54.00	Thrower
32.03	Eye Bolt
25.02	Connecting Frame
31.05	Stuffing Box
32.09	O-ring
26.00	Casing
19.00	Impeller
32.05	Key
31.01	Gland Packing / Mechanical Seal
31.02	Lantern Ring
22.00	Pump Shaft
31.04	Gland
13.05	Sleeve
25.01	Deflector
32.08	Oil Seal
29.01	Frame Support

MECHANICAL SEAL CONSTRUCTION

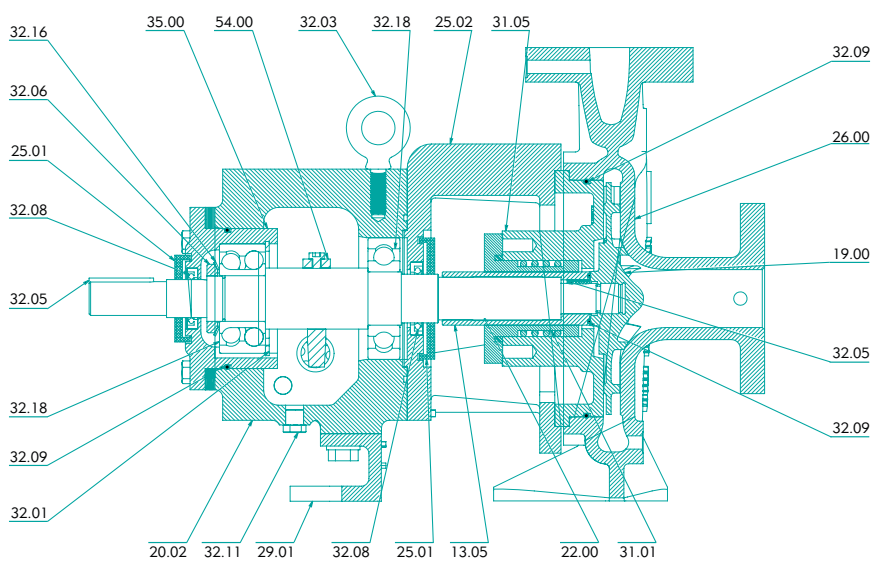

PERFORMANCE CURVES

Model : **TEC - 1.5 x 1 x 6**

Speed : **1450 rpm**

Suc x Del (in Inches) : **1.5 x 1**

Max. Impeller Ø : **150mm**

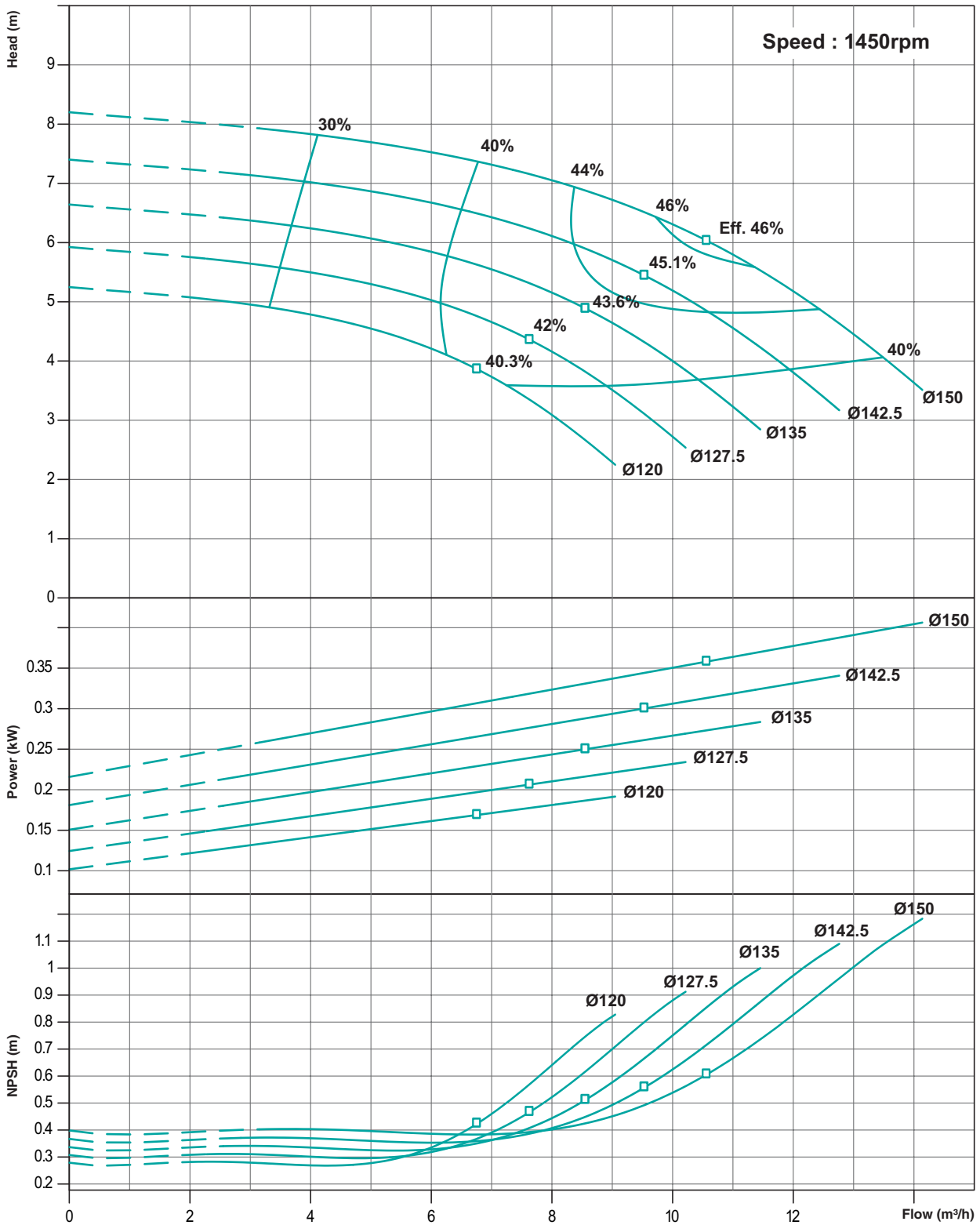

Performance curve tolerances are as per HI : 14.6 / ISO: 9906, Grade 2B

Note : Performance curve are as per specific gravity and viscosity of water.

PERFORMANCE CURVES

Model : **TEC - 1.5 x 1 x 6**

Speed : **2900 rpm**

Suc x Del (in Inches) : **1.5 x 1**

Max. Impeller Ø : **150mm**

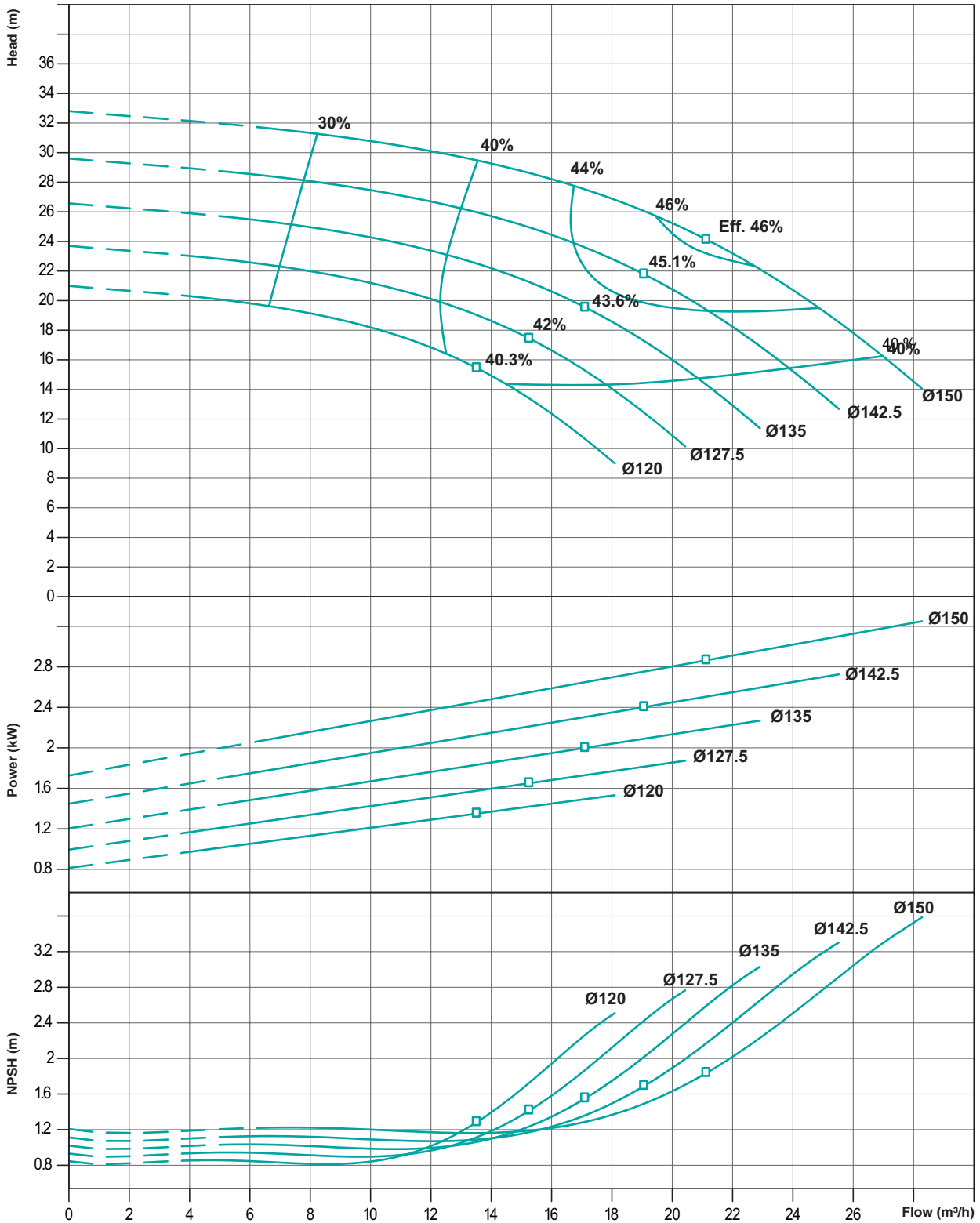

Performance curve tolerances are as per HI : 14.6 / ISO: 9906, Grade 2B

Note : Performance curve are as per specific gravity and viscosity of water.

PERFORMANCE CURVES

Model : **TEC - 3 x 1.5 x 6**

Speed : **1450 rpm**

Suc x Del (in Inches) : **3 x 1.5**

Max. Impeller Ø : **150mm**

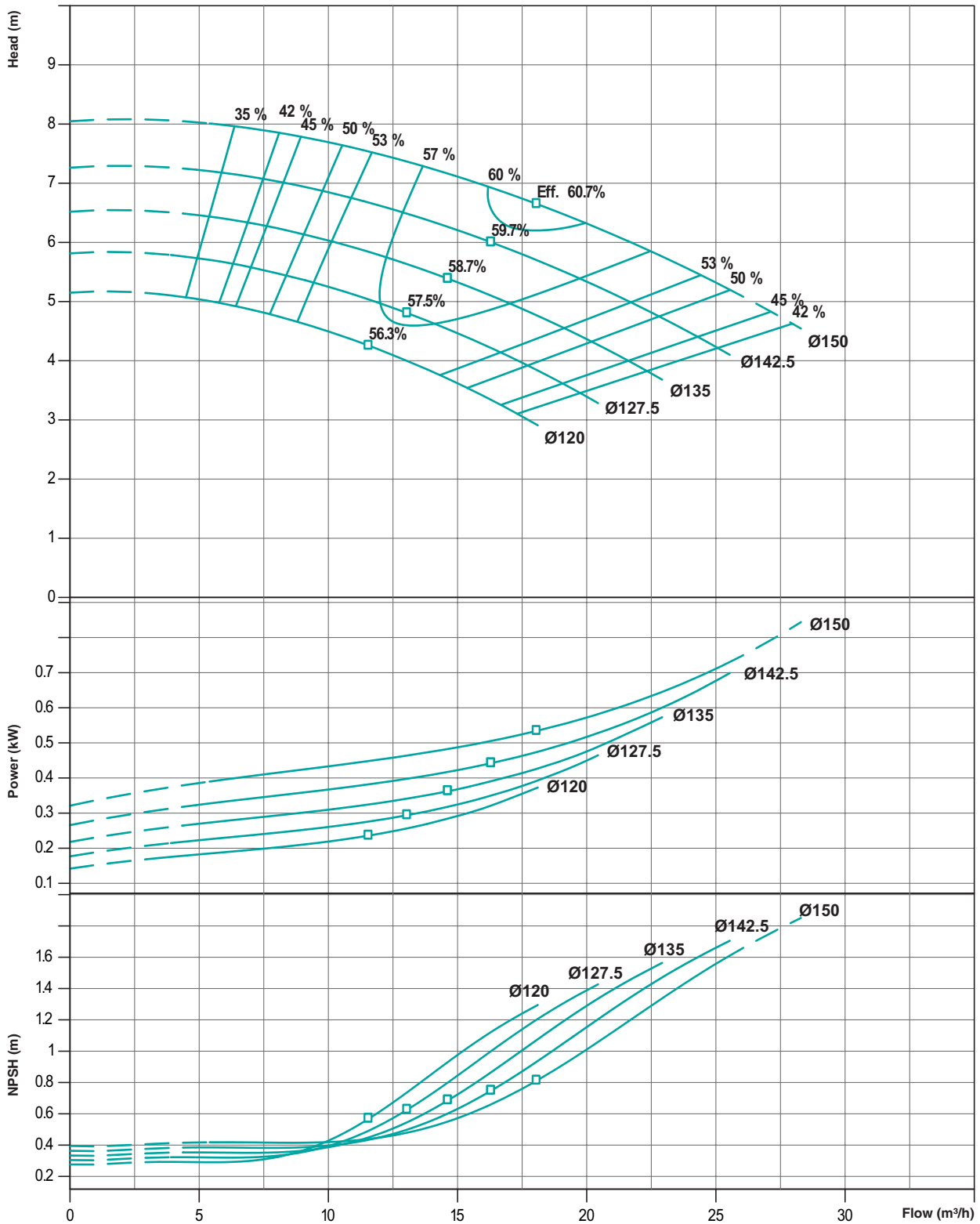

Performance curve tolerances are as per HI : 14.6 / ISO : 9906, Grade 2B

Note : Performance curve are as per specific gravity and viscosity of water.

PERFORMANCE CURVES

Model : **TEC - 3 x 1.5 x 6**

Speed : **2900 rpm**

Suc x Del (in Inches) : **3 x 1.5**

Max. Impeller Ø : **150mm**

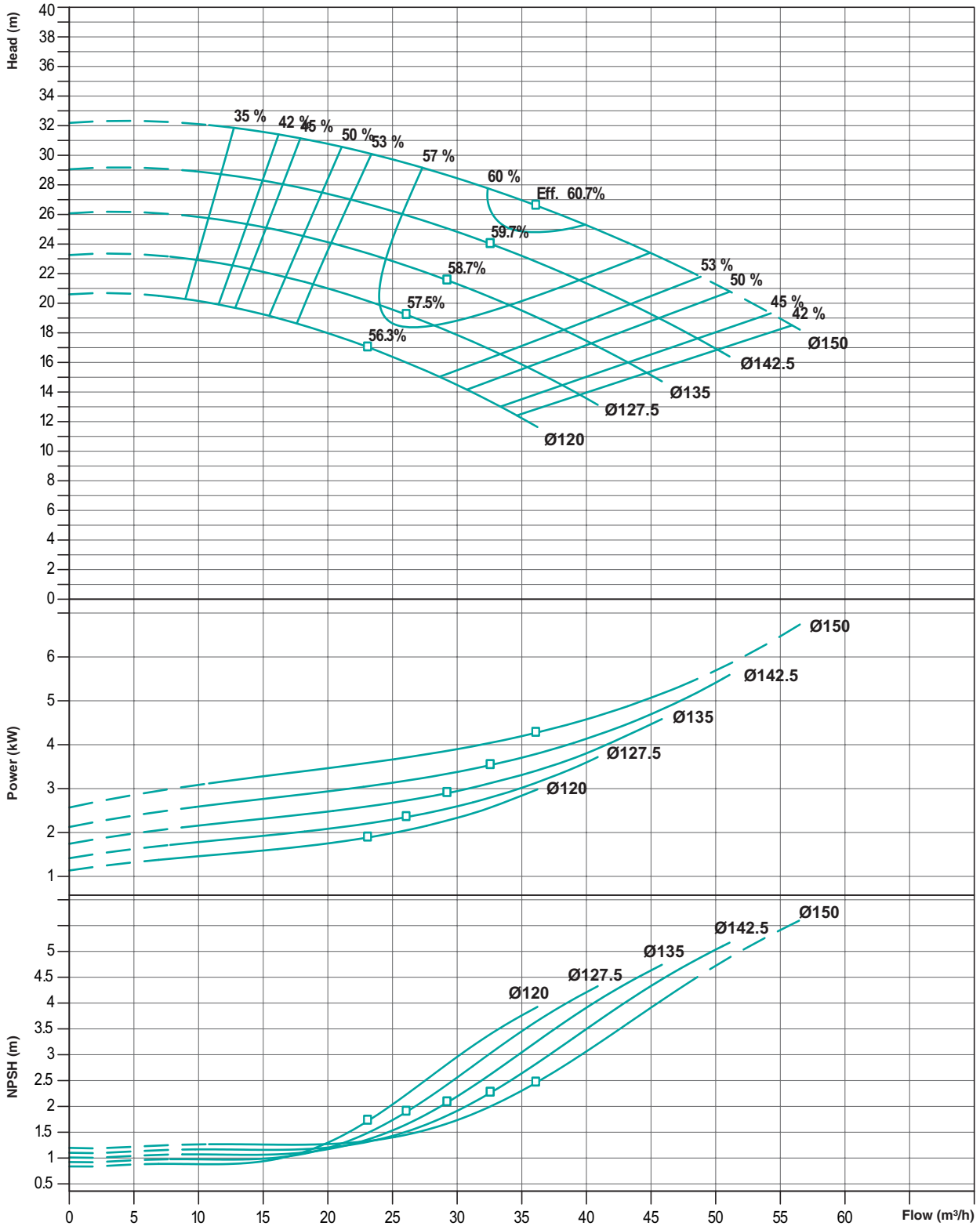

Performance curve tolerances are as per HI : 14.6 / ISO : 9906, Grade 2B

Note : Performance curve are as per specific gravity and viscosity of water.

PERFORMANCE CURVES

Model : **TEC - 3 x 2 x 6**

Speed : **1450 rpm**

Suc x Del (in Inches) : **3 x 2**

Max. Impeller Ø : **150mm**

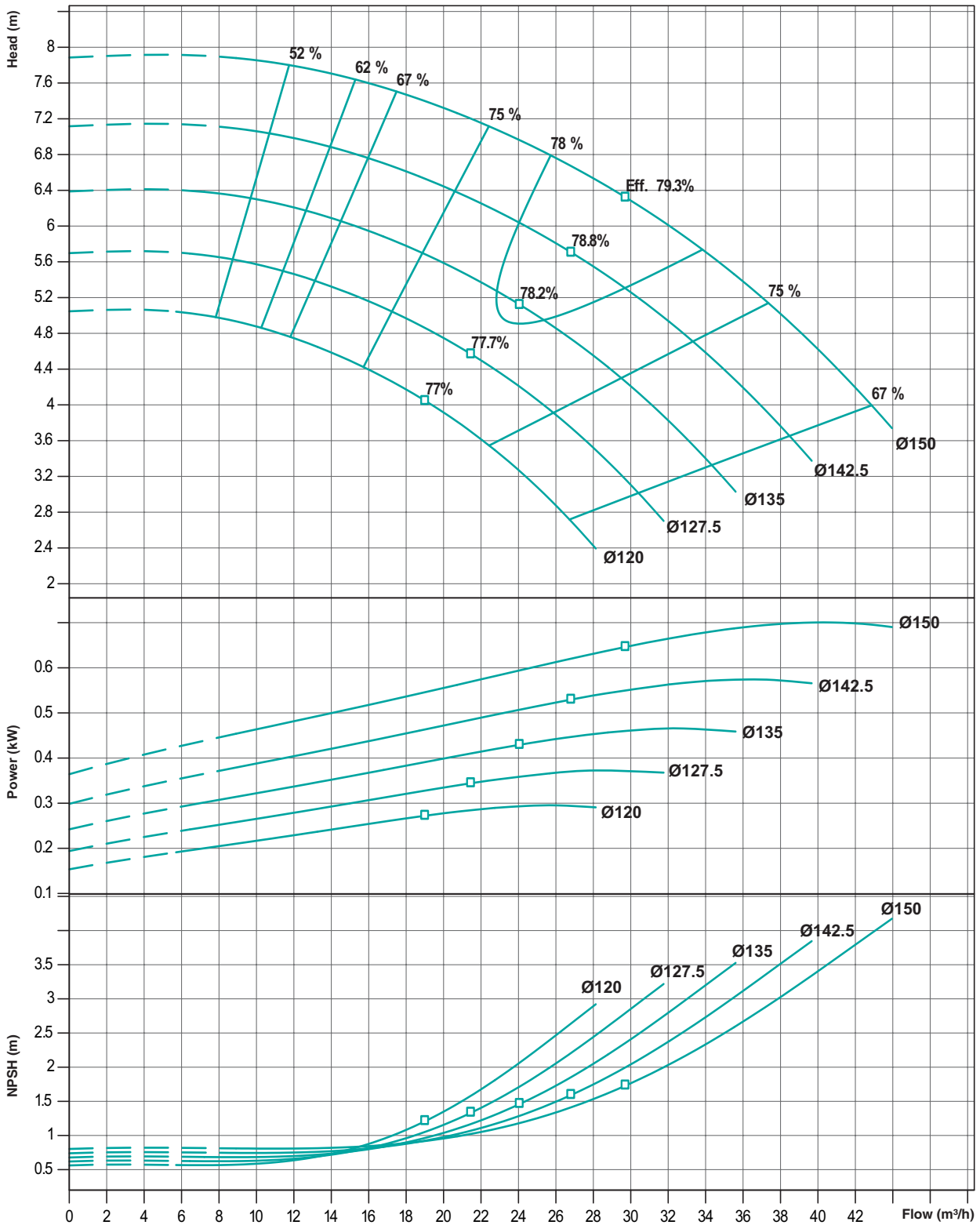

Performance curve tolerances are as per HI : 14.6 / ISO : 9906, Grade 2B

Note : Performance curve are as per specific gravity and viscosity of water.

PERFORMANCE CURVES

Model : **TEC - 3 x 2 x 6**

Speed : **2900 rpm**

Suc x Del (in Inches) : **3 x 1.5**

Max. Impeller Ø : **150mm**

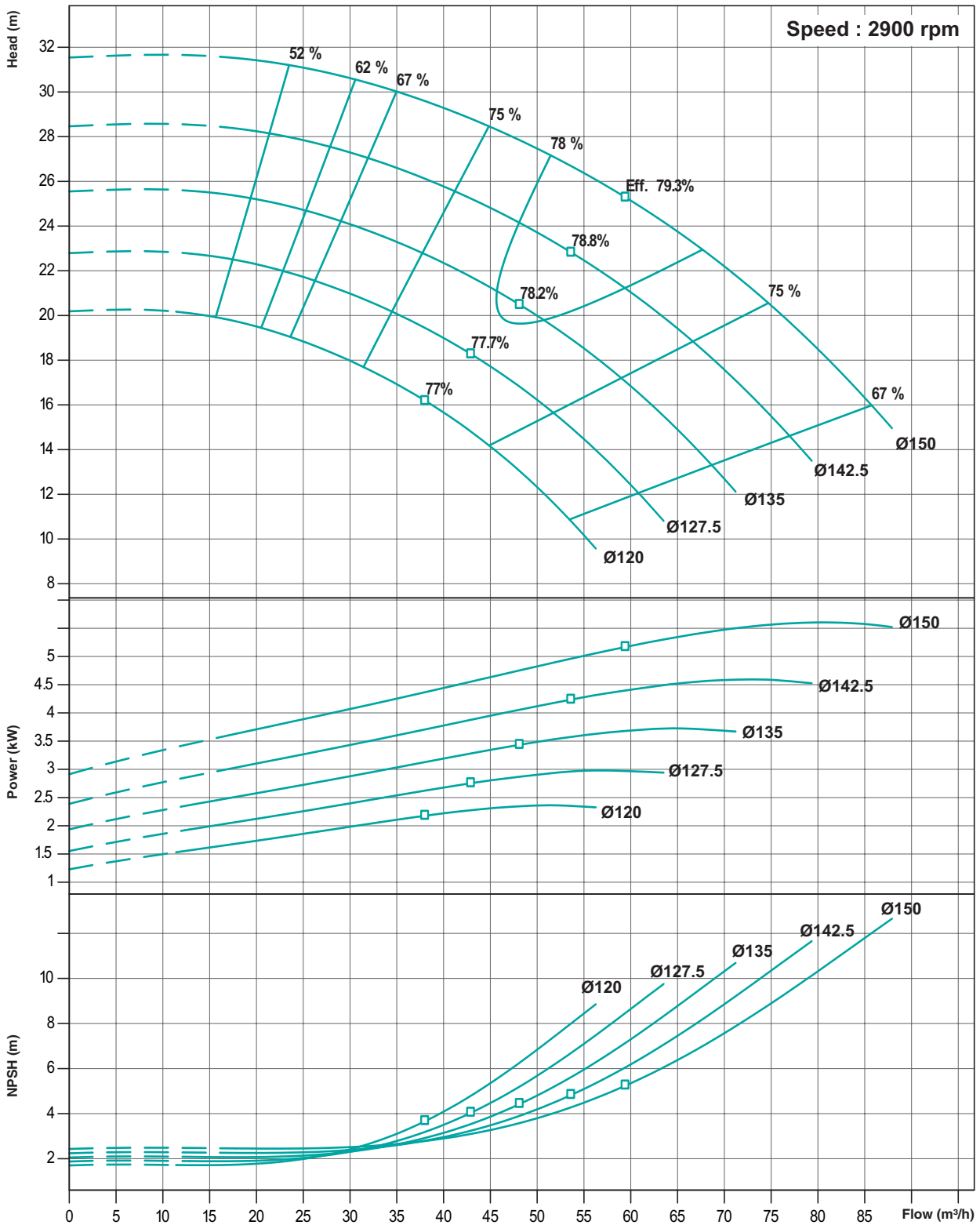

Performance curve tolerances are as per HI : 14.6 / ISO: 9906, Grade 2B

Note : Performance curve are as per specific gravity and viscosity of water.

PERFORMANCE CURVES

Model : **TEC - 1.5 x 1 x 8**

Speed : **1450 rpm**

Suc x Del (in Inches) : **1.5 x 1**

Max. Impeller Ø : **205mm**

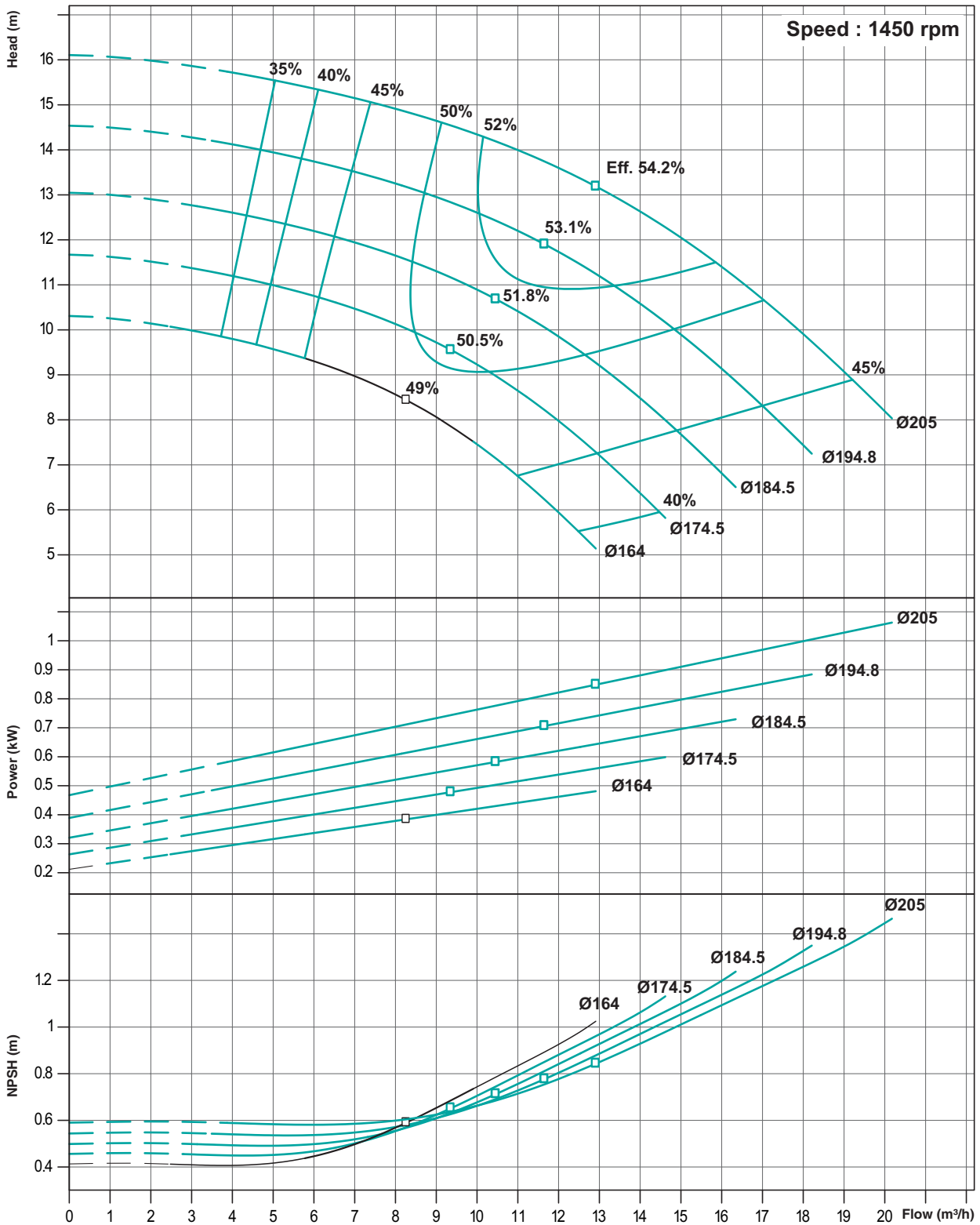

Performance curve tolerances are as per HI : 14.6 / ISO: 9906, Grade 2B

Note : Performance curve are as per specific gravity and viscosity of water.

PERFORMANCE CURVES

Model : **TEC - 1.5 x 1 x 8**

Speed : **2900 rpm**

Suc x Del (in Inches) : **1.5 x 1**

Max. Impeller Ø : **205mm**

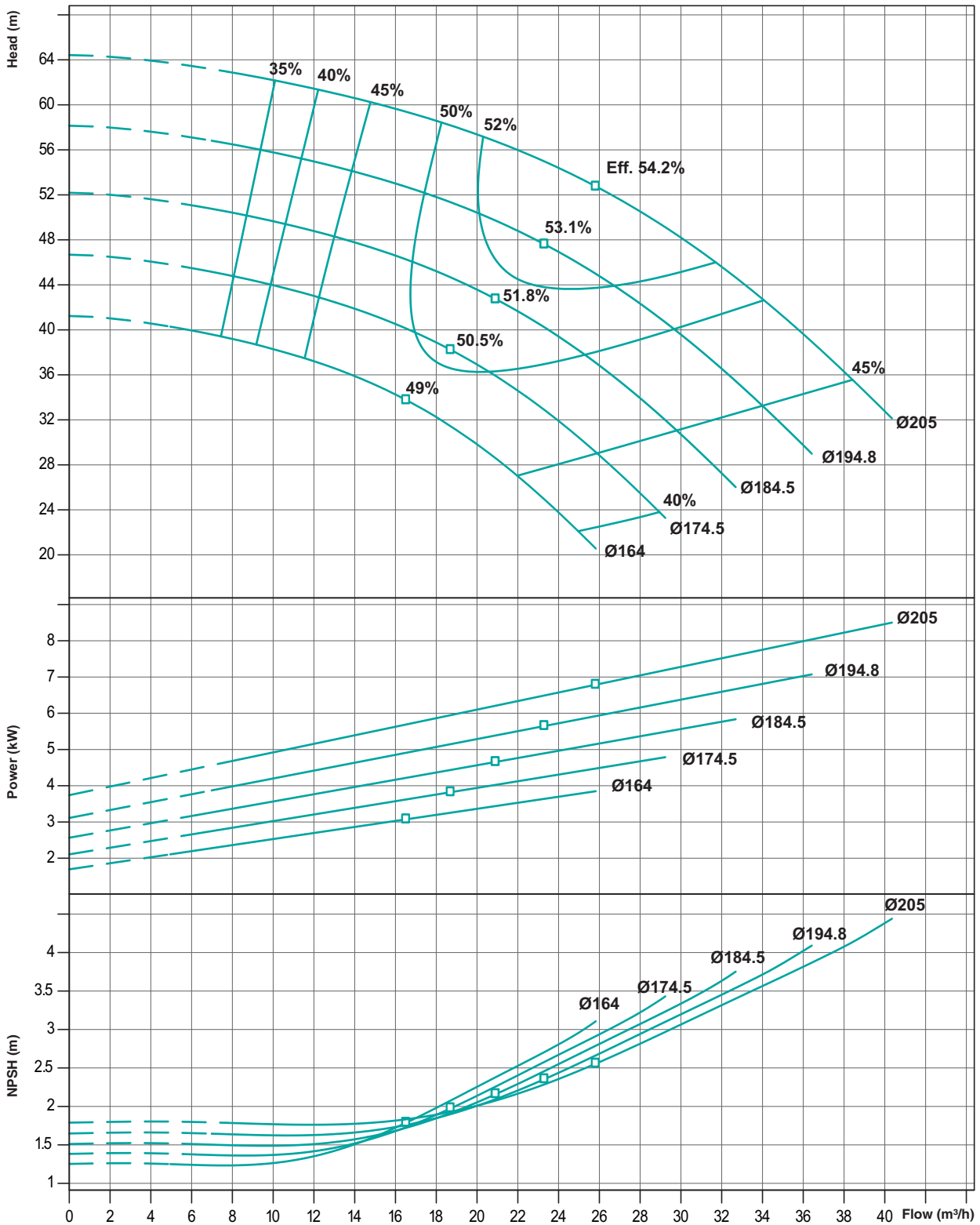

Performance curve tolerances are as per HI : 14.6 / ISO: 9906, Grade 2B

Note : Performance curve are as per specific gravity and viscosity of water.

PERFORMANCE CURVES

Model : **TEC - 3 x 1.5 x 8**

Speed : **1450 rpm**

Suc x Del (in Inches) : **3 x 1.5**

Max. Impeller Ø : **205mm**

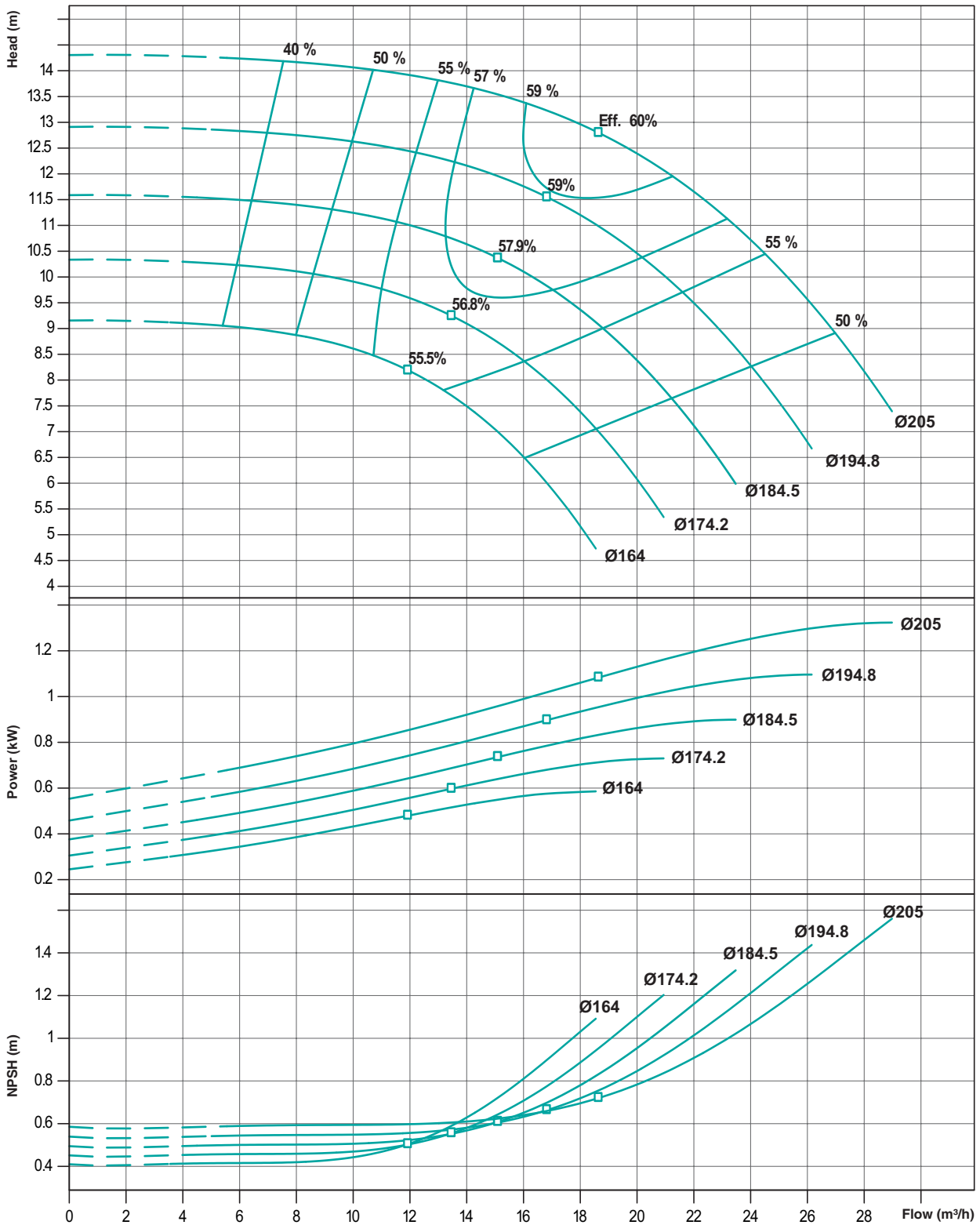

Performance curve tolerances are as per HI : 14.6 / ISO: 9906, Grade 2B

Note : Performance curve are as per specific gravity and viscosity of water.

PERFORMANCE CURVES

Model : **TEC - 3 x 1.5 x 8**

Speed : **2900 rpm**

Suc x Del (in Inches) : **3 x 1.5**

Max. Impeller Ø : **205mm**

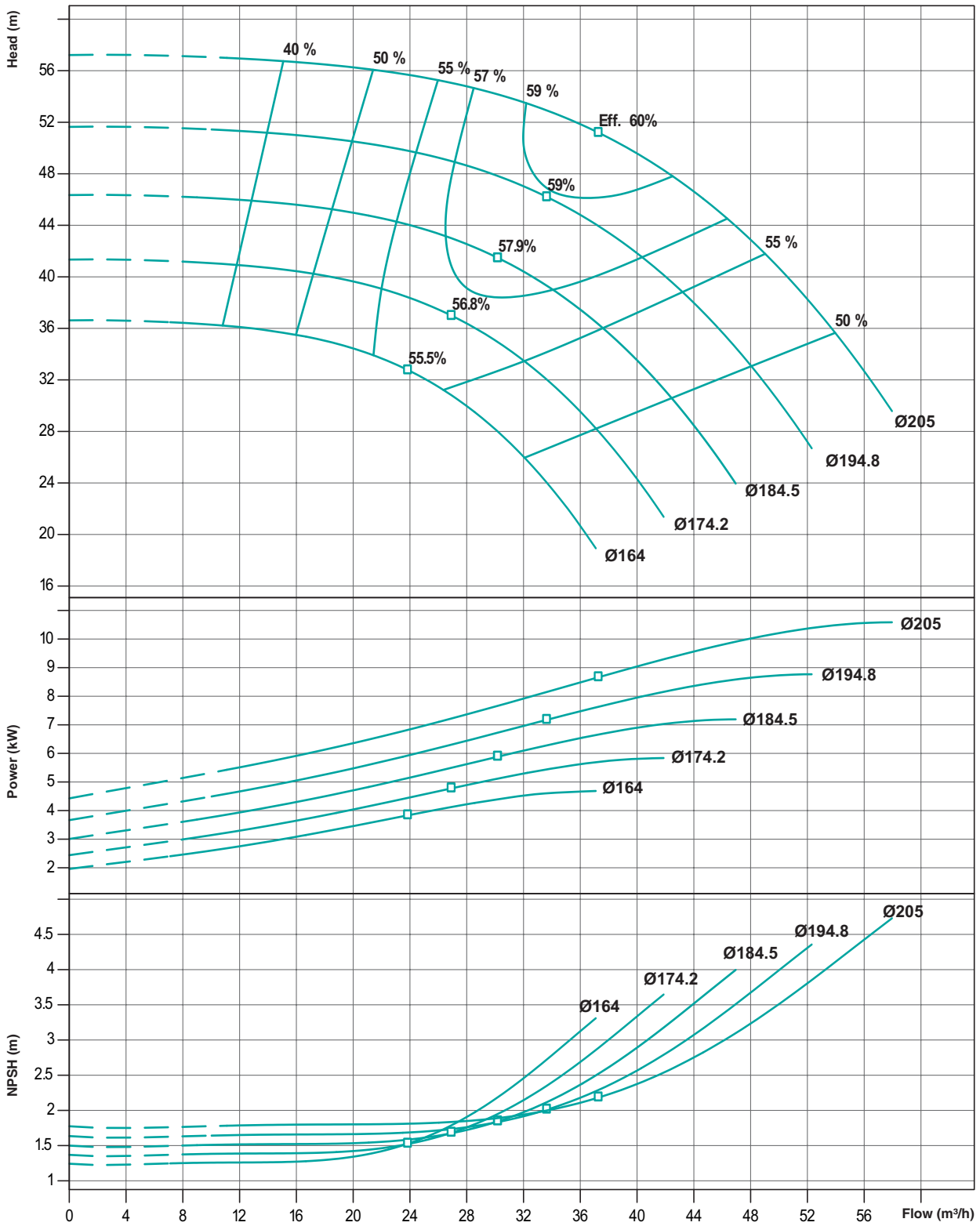

Performance curve tolerances are as per HI : 14.6 / ISO: 9906, Grade 2B

Note : Performance curve are as per specific gravity and viscosity of water.

PERFORMANCE CURVES

Model : **TEC - 3 x 1.5 x 8.5**

Speed : **1450 rpm**

Suc x Del (in Inches) : **3 x 1.5**

Max. Impeller Ø : **215mm**

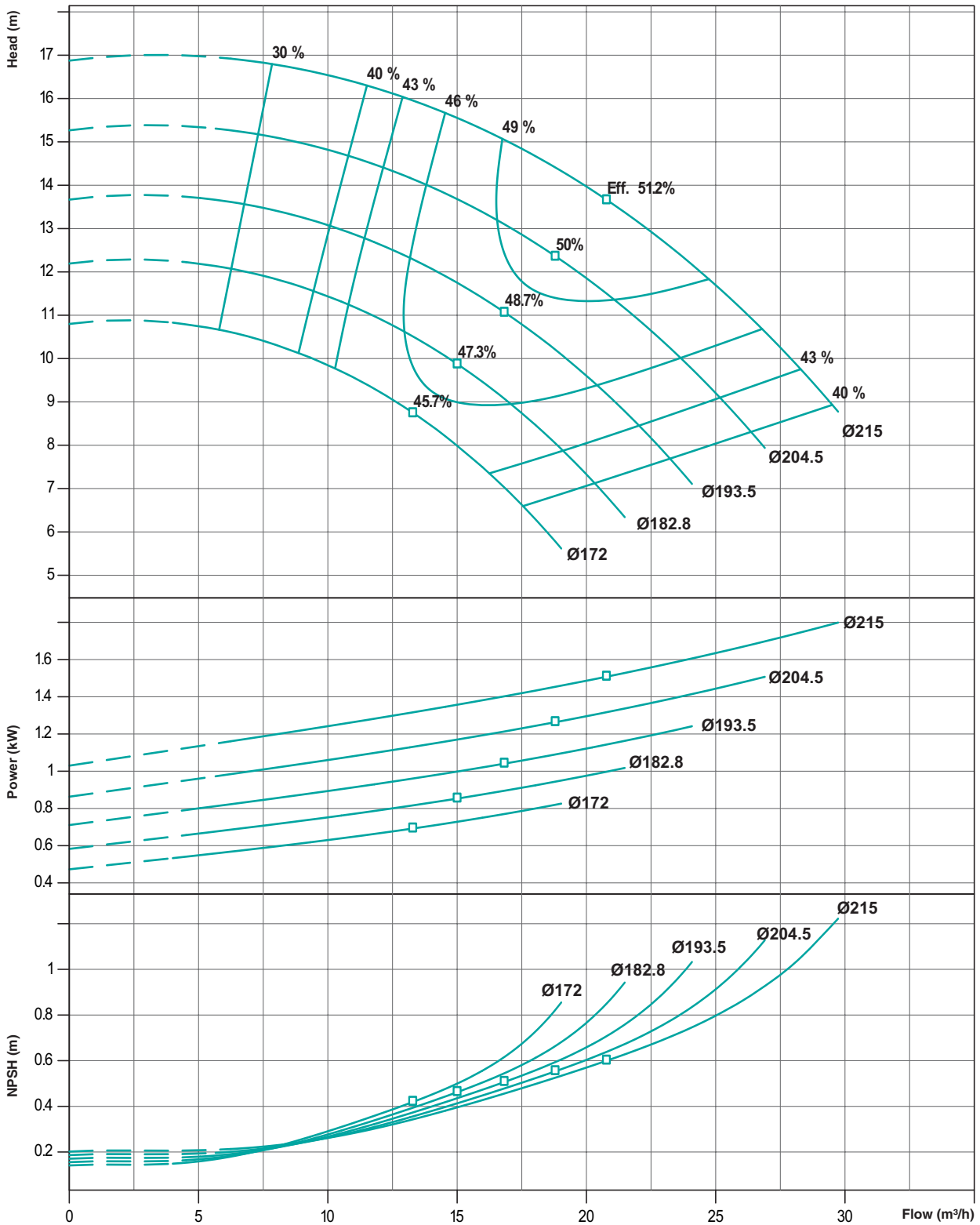

Performance curve tolerances are as per HI : 14.6 / ISO : 9906, Grade 2B

Note : Performance curve are as per specific gravity and viscosity of water.

PERFORMANCE CURVES

Model : **TEC - 3 x 1.5 x 8.5**

Speed : **2900 rpm**

Suc x Del (in Inches) : **3 x 1.5**

Max. Impeller Ø : **215mm**

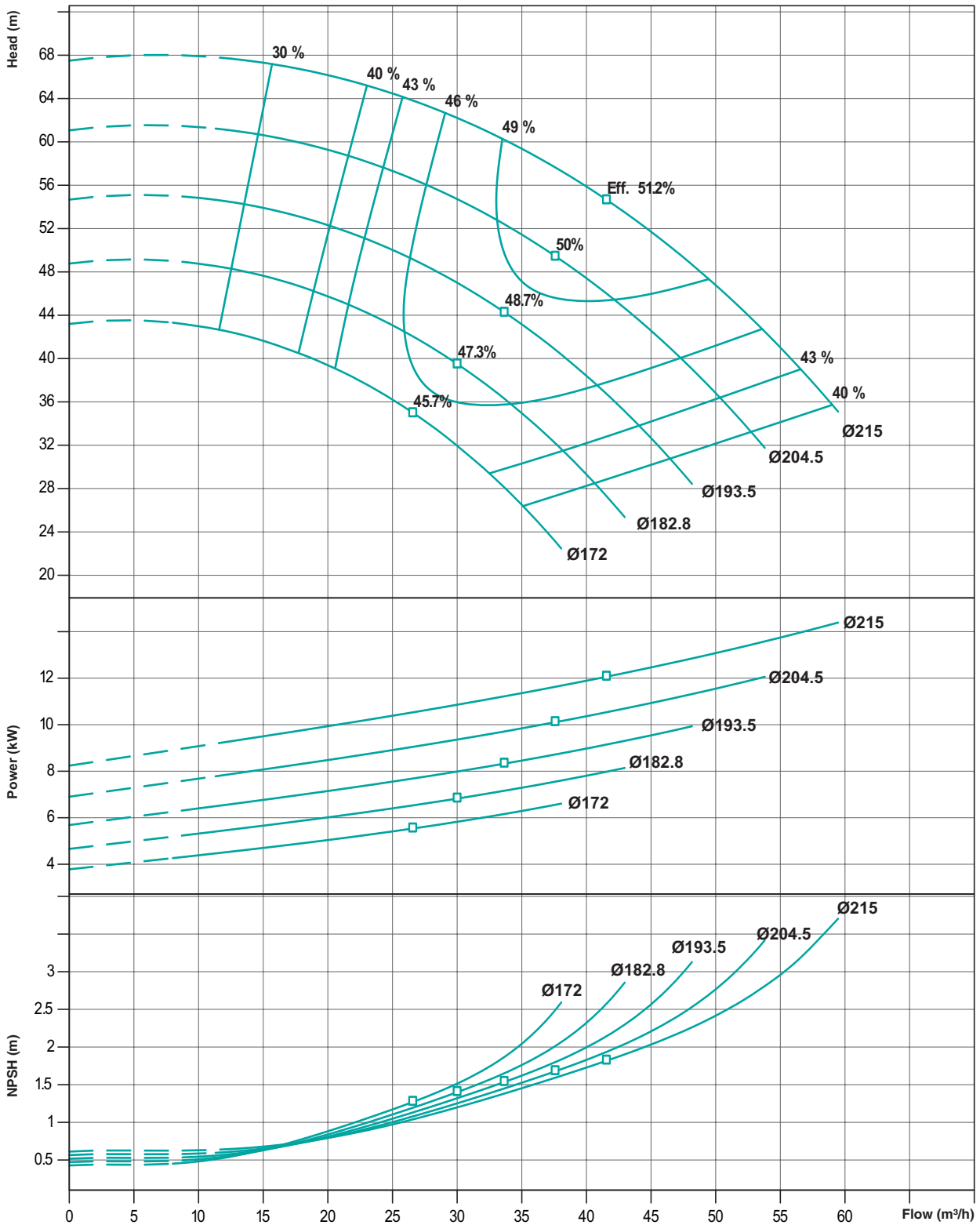

Performance curve tolerances are as per HI : 14.6 / ISO : 9906, Grade 2B

Note : Performance curve are as per specific gravity and viscosity of water.

PERFORMANCE CURVES

Model : **TEC - 3 x 2 x 8.5**

Speed : **1450 rpm**

Suc x Del (in Inches) : **3 x 2**

Max. Impeller Ø : **215mm**

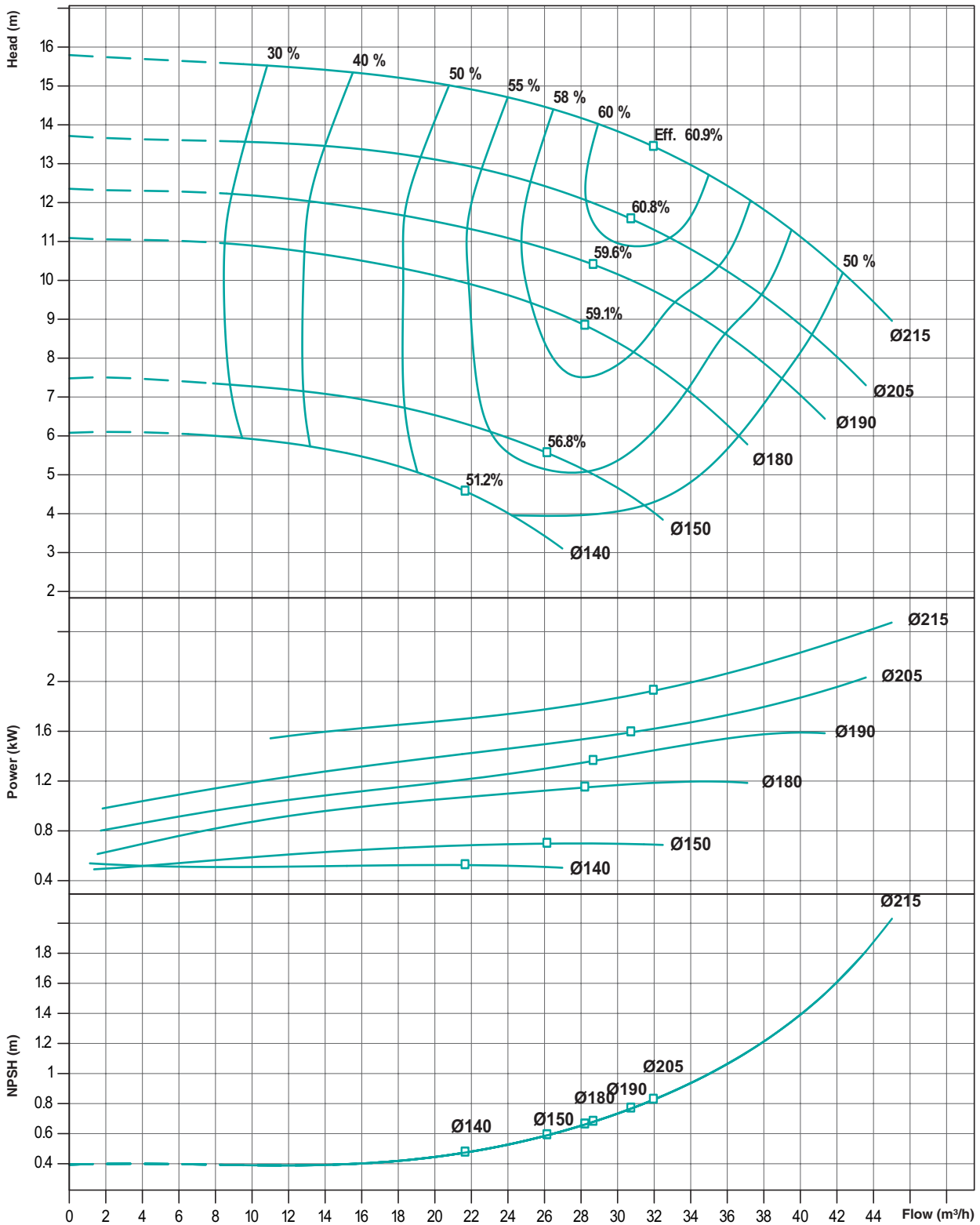

Performance curve tolerances are as per HI : 14.6 / ISO: 9906, Grade 2B

Note : Performance curve are as per specific gravity and viscosity of water.

PERFORMANCE CURVES

Model : **TEC - 3 x 2 x 8.5**

Speed : **2900 rpm**

Suc x Del (in Inches) : **3 x 2**

Max. Impeller Ø : **215mm**

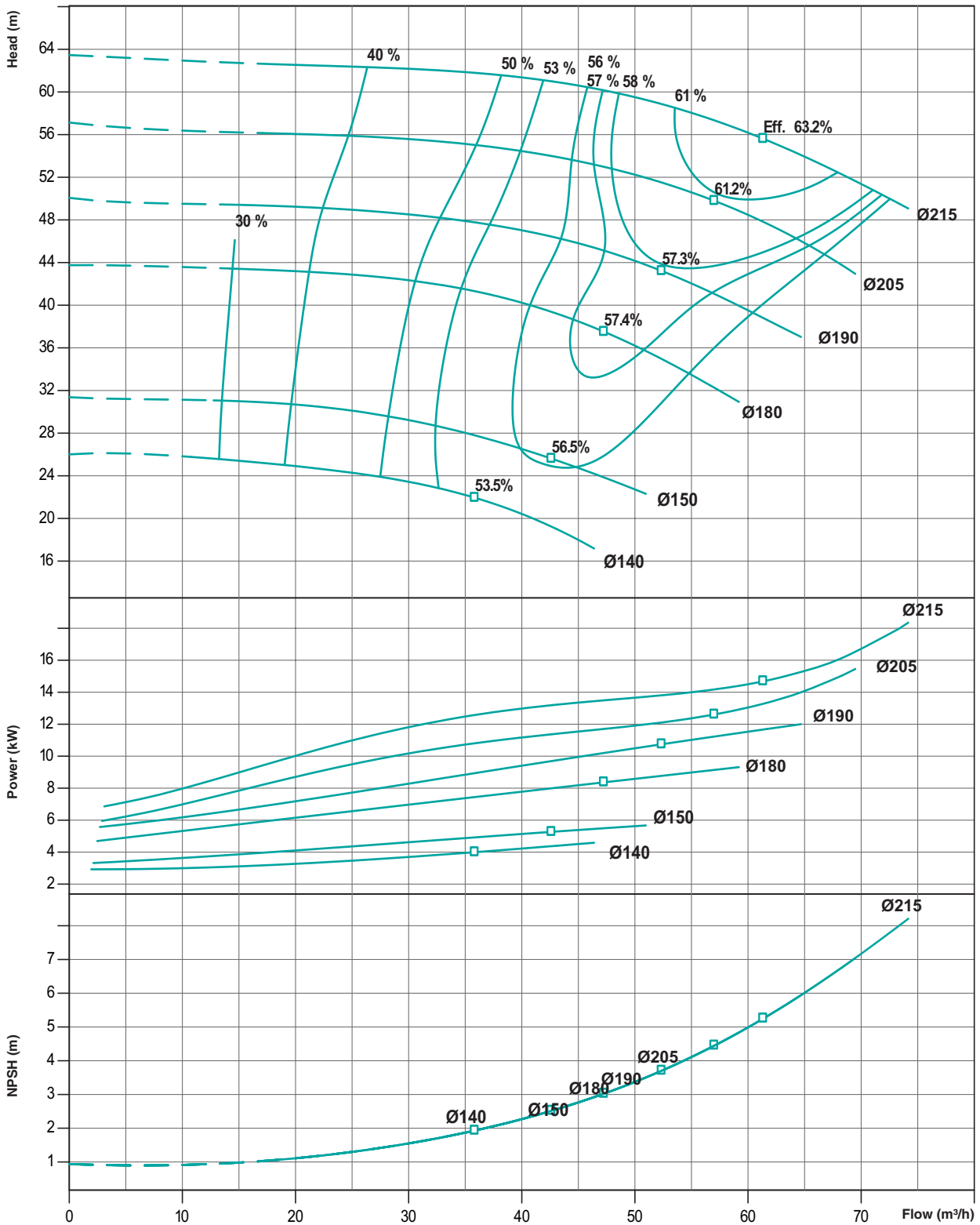

Performance curve tolerances are as per HI : 14.6 / ISO : 9906, Grade 2B

Note : Performance curve are as per specific gravity and viscosity of water.

PERFORMANCE CURVES

Model : **TEC - 4 x 3 x 8.5**

Speed : **1450 rpm**

Suc x Del (in Inches) : **4 x 3**

Max. Impeller Ø : **215mm**

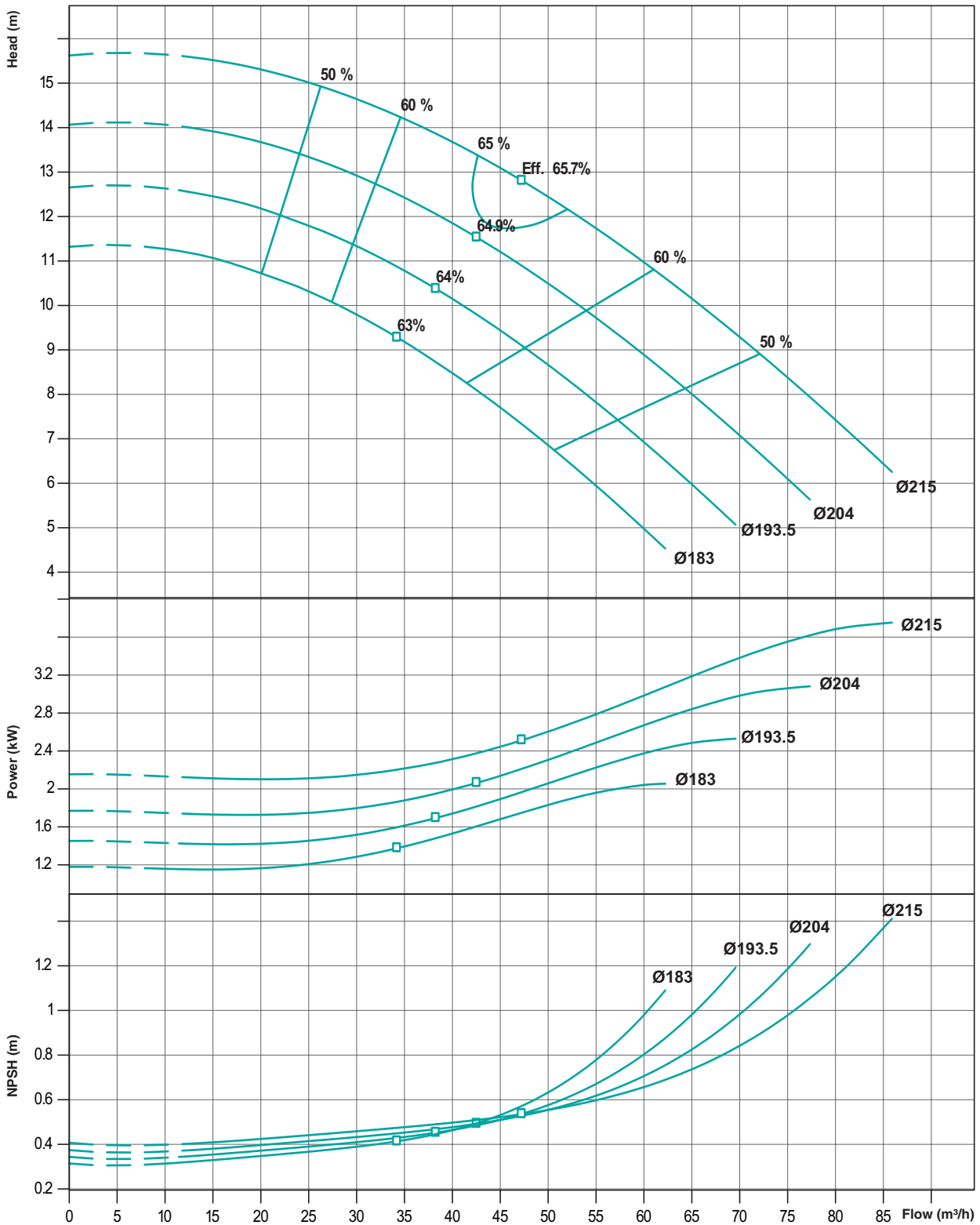

Performance curve tolerances are as per HI : 14.6 / ISO: 9906, Grade 2B

Note : Performance curve are as per specific gravity and viscosity of water.

PERFORMANCE CURVES

Model : **TEC - 4 x 3 x 8.5**

Speed : **2900 rpm**

Suc x Del (in Inches) : **4 x 3**

Max. Impeller Ø : **215mm**

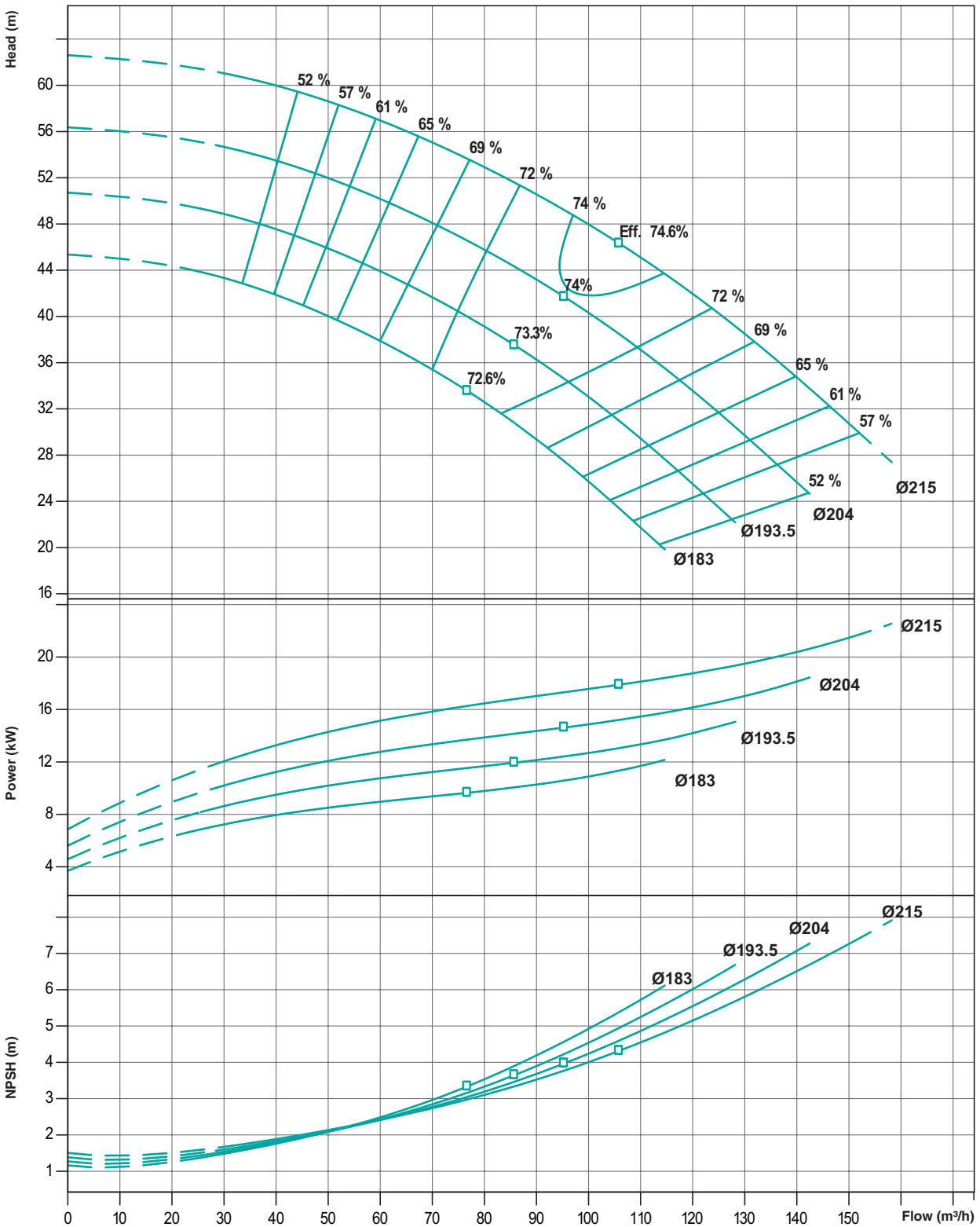

Performance curve tolerances are as per HI : 14.6 / ISO: 9906, Grade 2B

Note : Performance curve are as per specific gravity and viscosity of water.

PERFORMANCE CURVES

Model : **TEC - 6 x 4 x 8.5**

Speed : **2900 rpm**

Suc x Del (in Inches) : **6 x 4**

Max. Impeller Ø : **215mm**

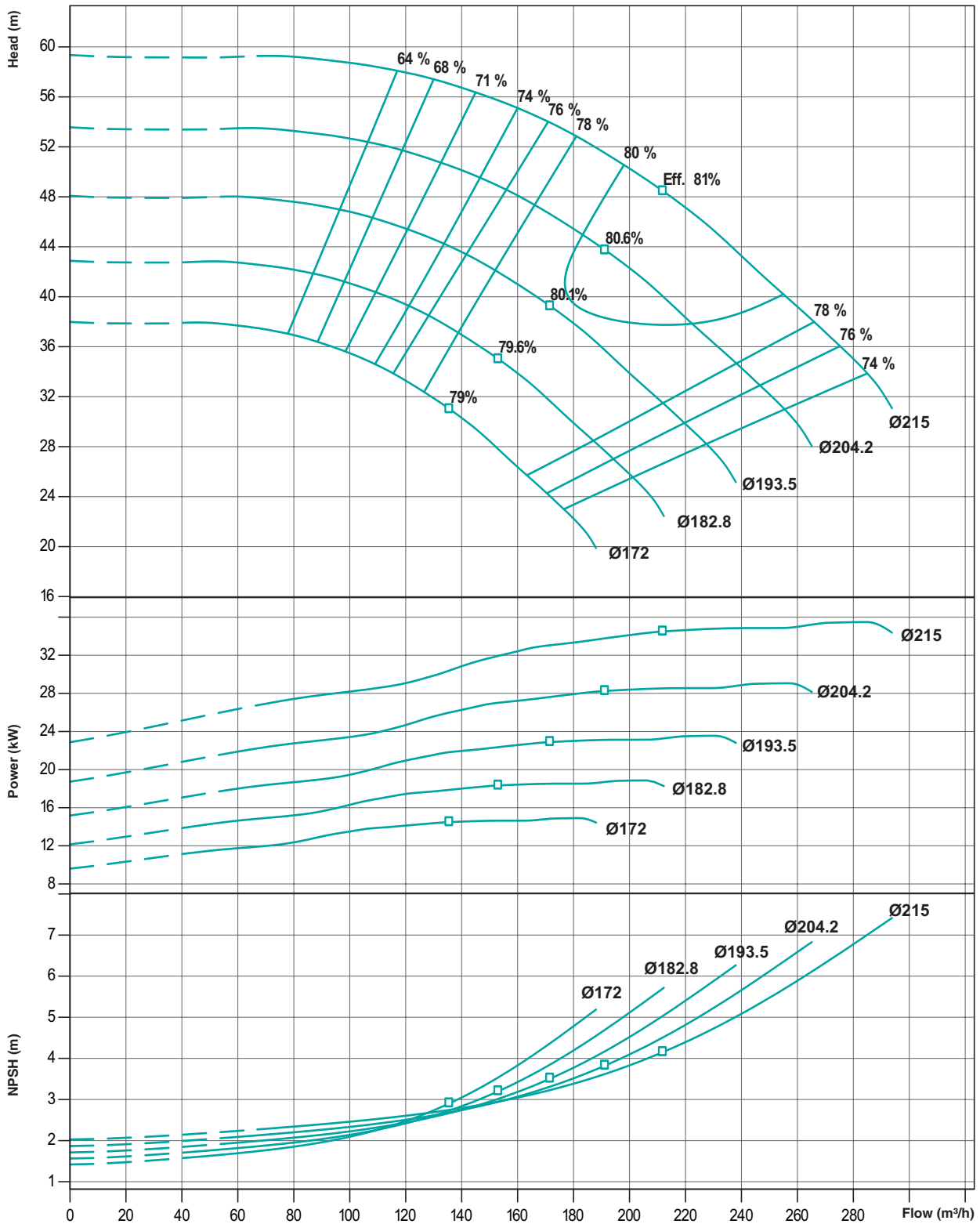

Performance curve tolerances are as per HI : 14.6 / ISO : 9906, Grade 2B

Note : Performance curve are as per specific gravity and viscosity of water.

PERFORMANCE CURVES

Model : **TEC - 2 x 1 x 10**

Speed : **1450 rpm**

Suc x Del (in Inches) : **2 x 1**

Max. Impeller Ø : **255mm**

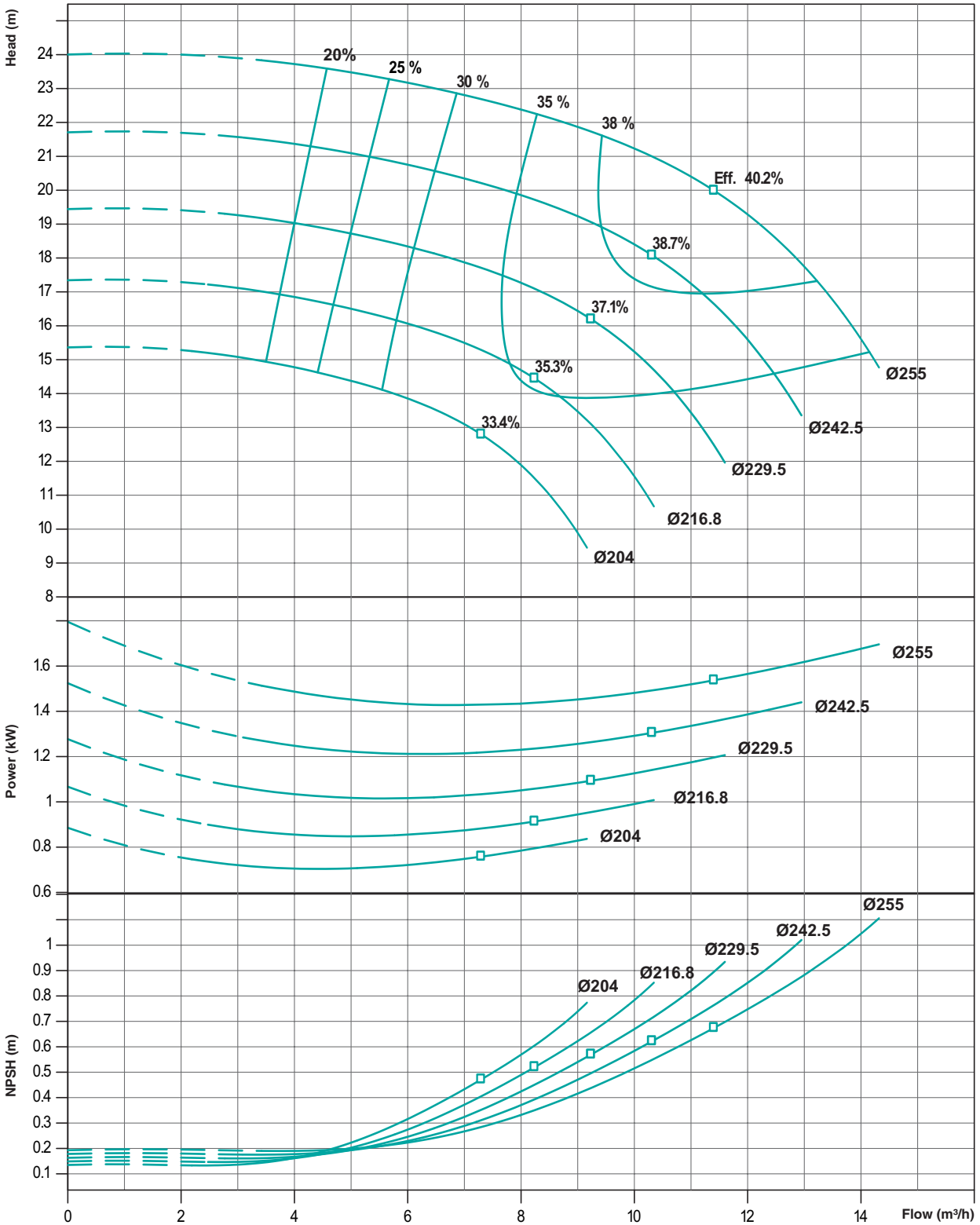

Performance curve tolerances are as per HI : 14.6 / ISO: 9906, Grade 2B

Note : Performance curve are as per specific gravity and viscosity of water.

PERFORMANCE CURVES

Model : **TEC - 2 x 1 x 10**

Speed : **2900 rpm**

Suc x Del (in Inches) : **2 x 1**

Max. Impeller Ø : **255mm**

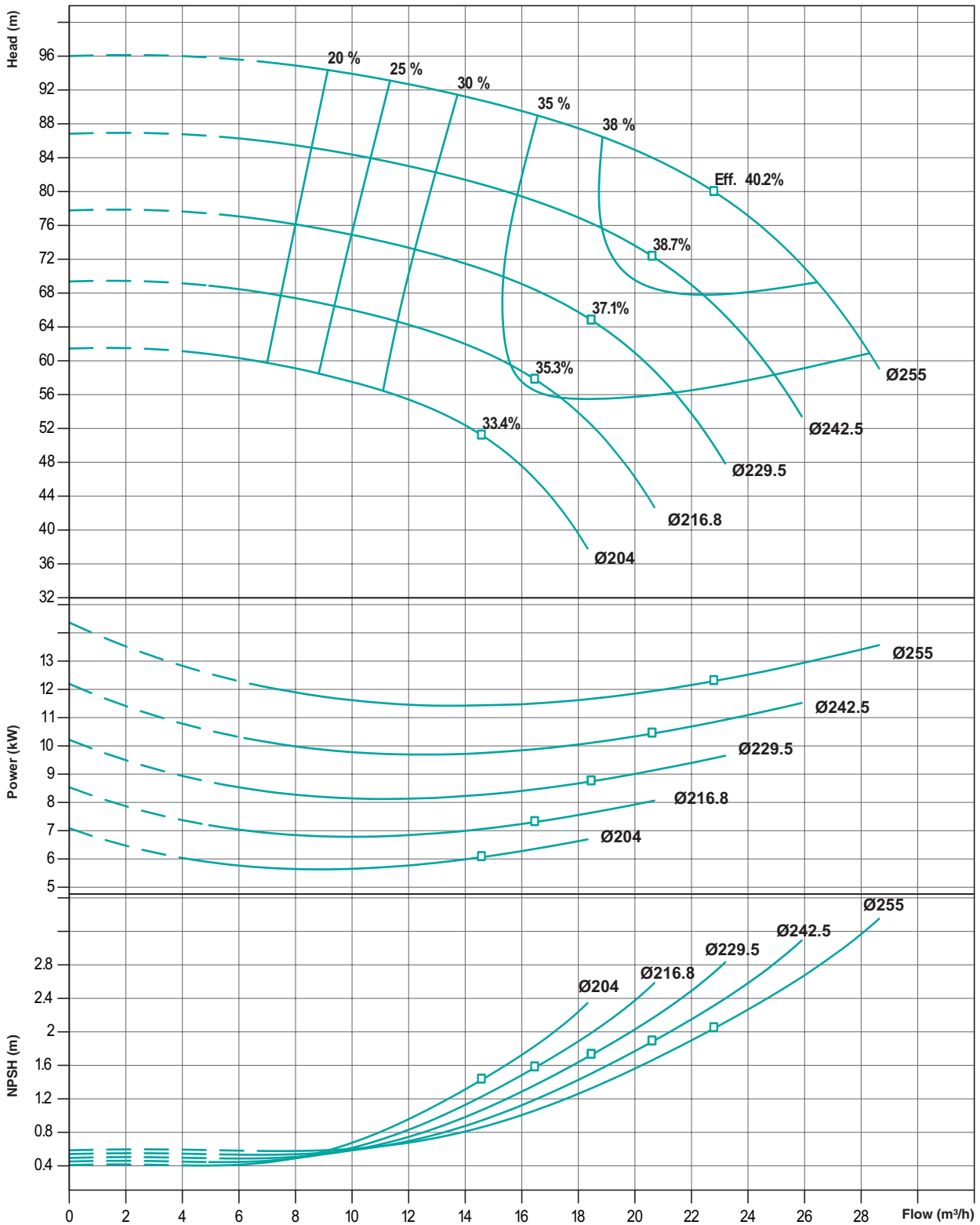

Performance curve tolerances are as per HI : 14.6 / ISO: 9906, Grade 2B

Note : Performance curve are as per specific gravity and viscosity of water.

PERFORMANCE CURVES

Model : **TEC - 5 x 4 x 10**

Speed : **1450 rpm**

Suc x Del (in Inches) : **5 x 4**

Max. Impeller Ø : **250mm**

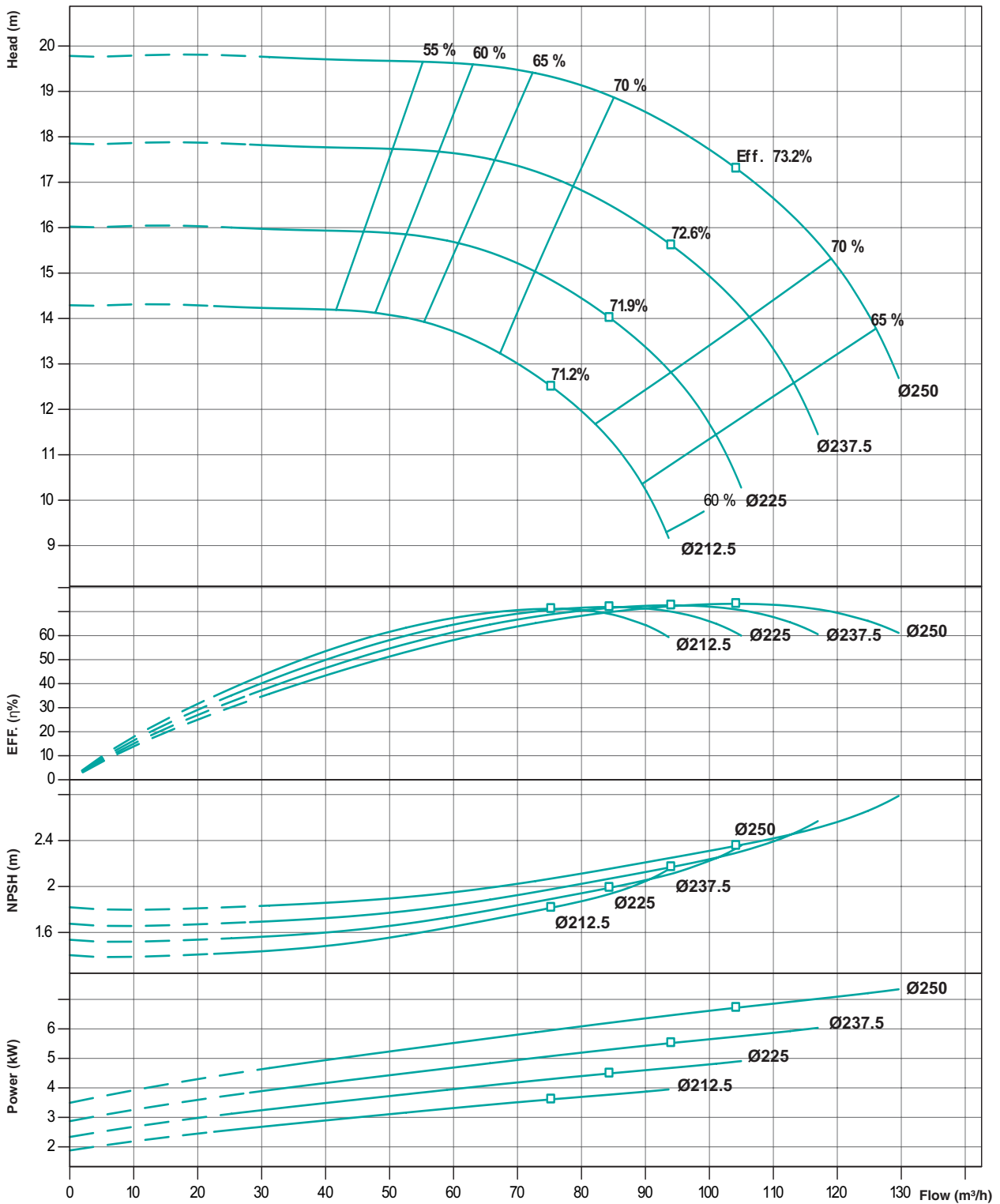

Performance curve tolerances are as per HI : 14.6 / ISO : 9906, Grade 2B

Note : Performance curve are as per specific gravity and viscosity of water.

PERFORMANCE CURVES

Model : **TEC - 5 x 4 x 10**

Speed : **2900 rpm**

Suc x Del (in Inches) : **5 x 4**

Max. Impeller Ø : **250mm**

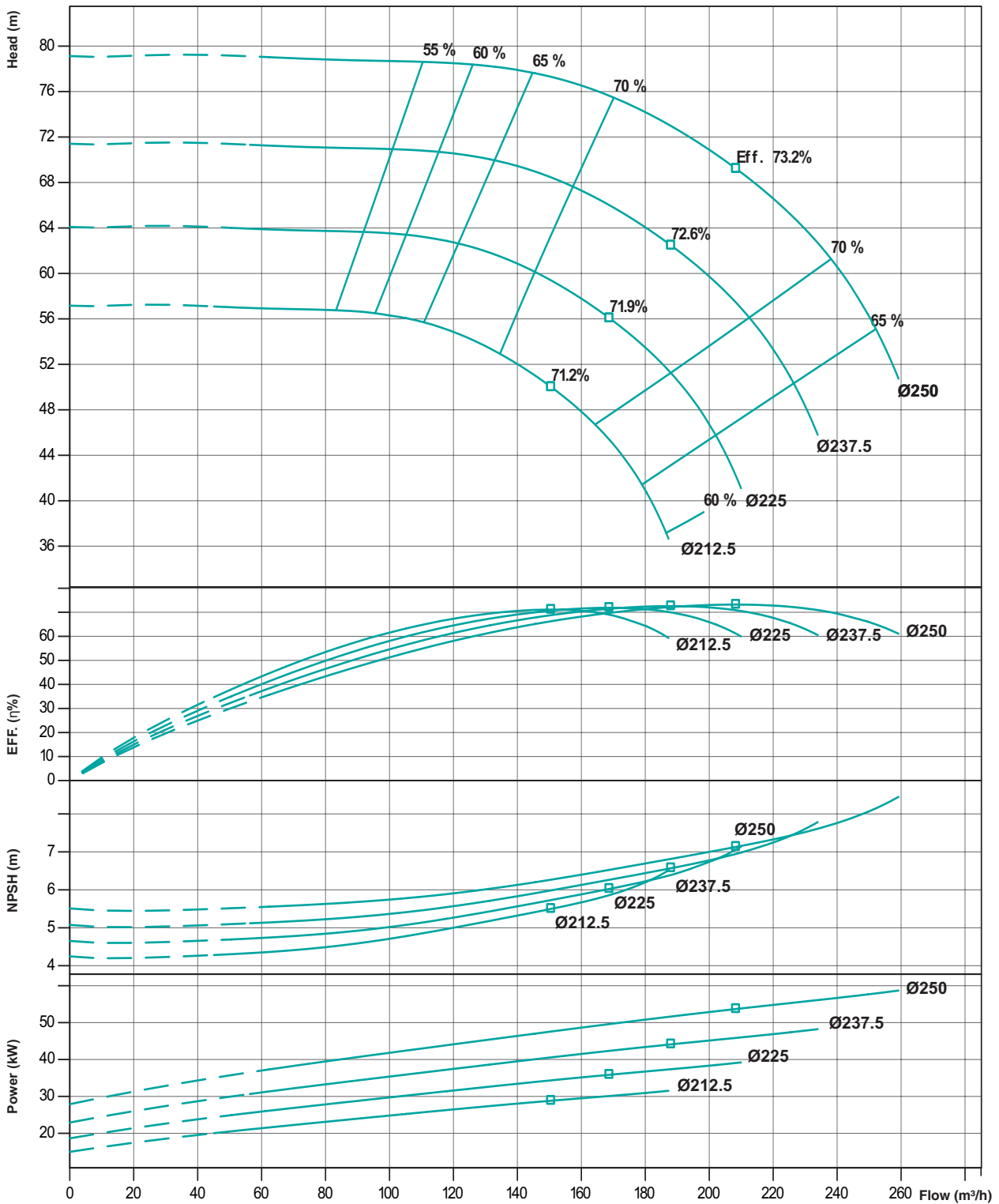

Performance curve tolerances are as per HI : 14.6 / ISO: 9906, Grade 2B

Note : Performance curve are as per specific gravity and viscosity of water.

PERFORMANCE CURVES

Model : **TEC - 3 x 1.5 x 11**

Speed : **1450 rpm**

Suc x Del (in Inches) : **3 x 1.5**

Max. Impeller Ø : **280mm**

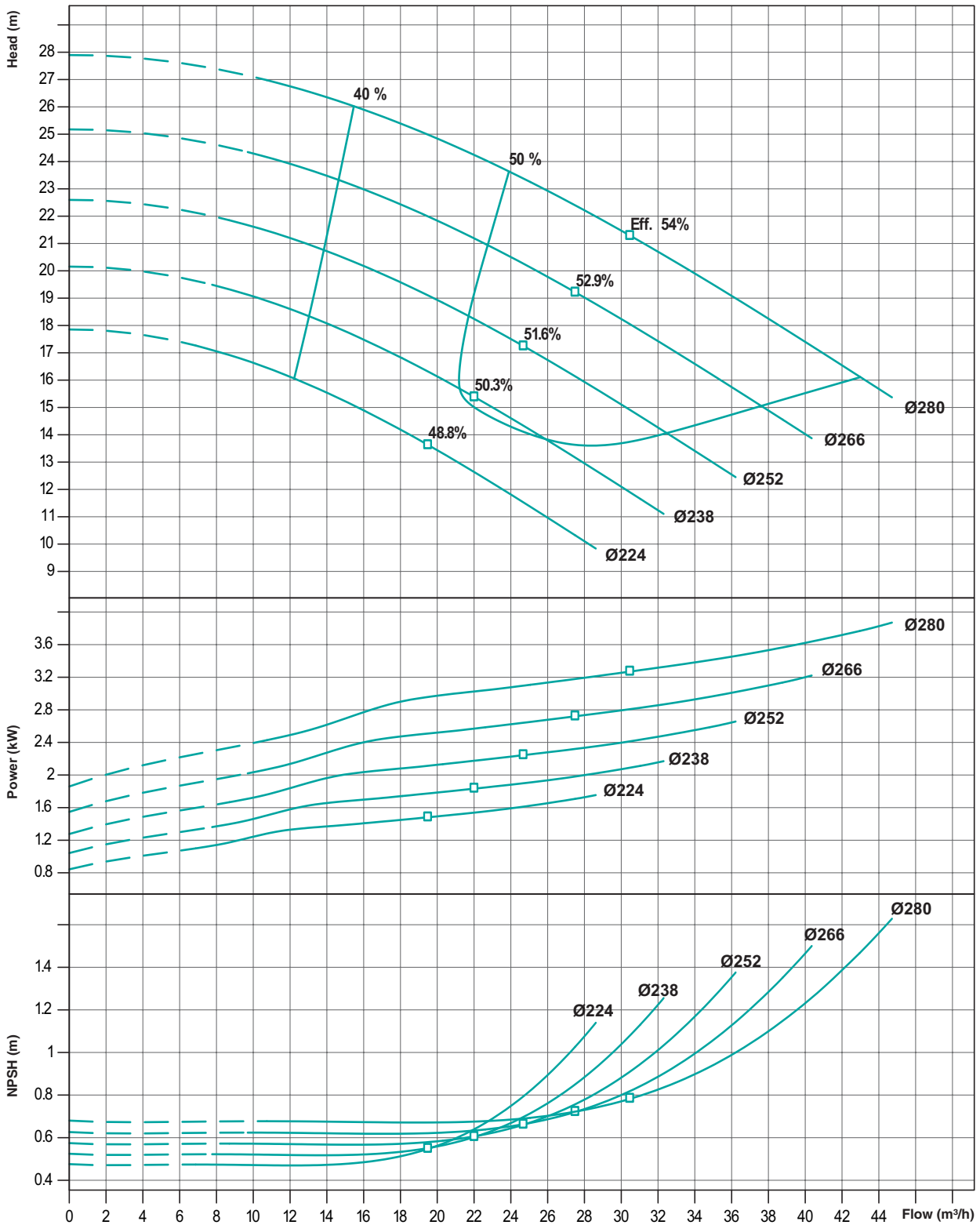

Performance curve tolerances are as per HI : 14.6 / ISO: 9906, Grade 2B

Note : Performance curve are as per specific gravity and viscosity of water.

PERFORMANCE CURVES

Model : **TEC - 3 x 1.5 x 11**

Speed : **2900 rpm**

Suc x Del (in Inches) : **3 x 1.5**

Max. Impeller Ø : **280mm**

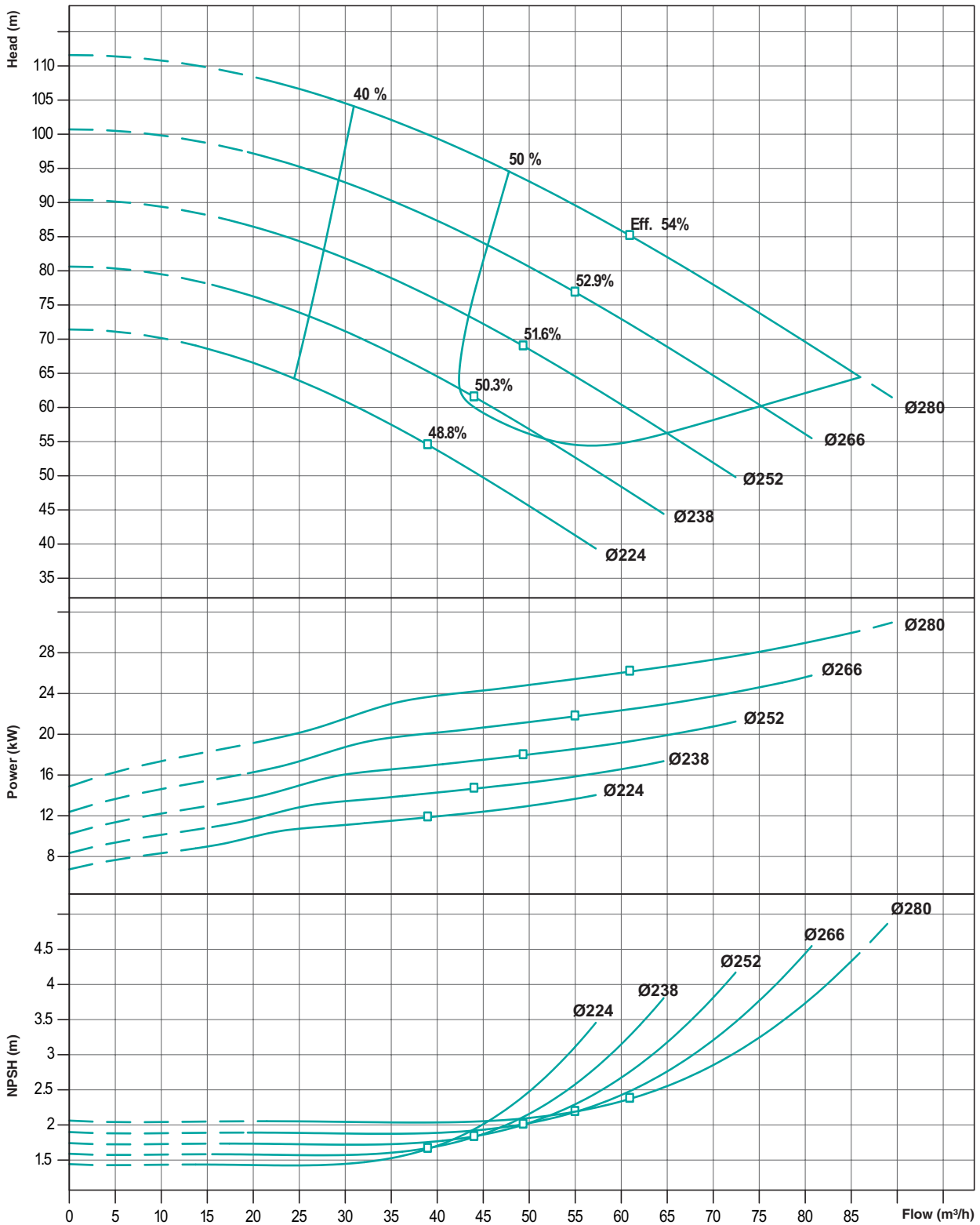

Performance curve tolerances are as per HI : 14.6 / ISO: 9906, Grade 2B

Note : Performance curve are as per specific gravity and viscosity of water.

PERFORMANCE CURVES

Model : **TEC - 3 x 2 x 11**

Speed : **1450 rpm**

Suc x Del (in Inches) : **3 x 2**

Max. Impeller Ø : **280mm**

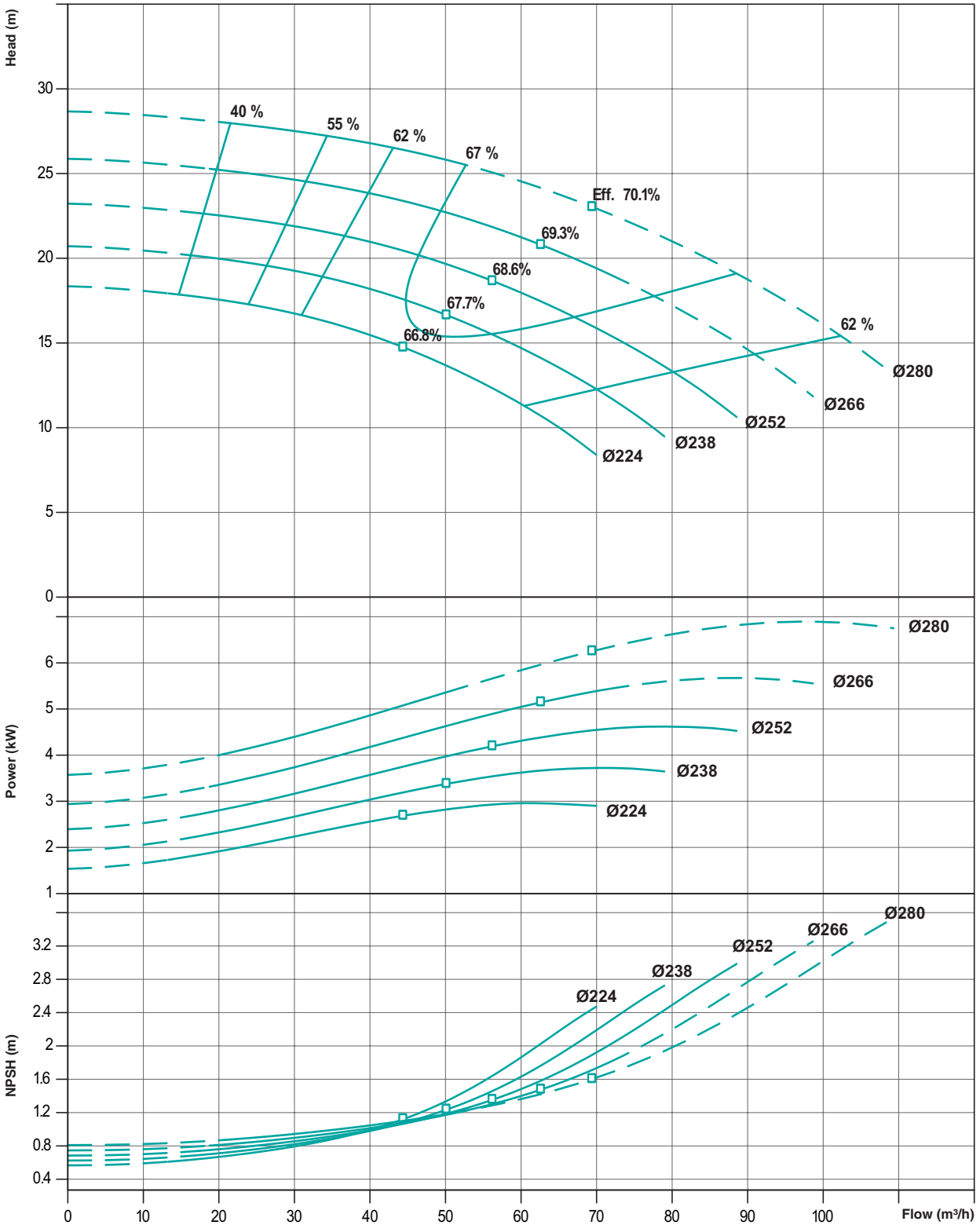

Performance curve tolerances are as per HI : 14.6 / ISO: 9906, Grade 2B

Note : Performance curve are as per specific gravity and viscosity of water.

PERFORMANCE CURVES

Model : **TEC - 3 x 2 x 11**

Speed : **2900 rpm**

Suc x Del (in Inches) : **3 x 2**

Max. Impeller Ø : **280mm**

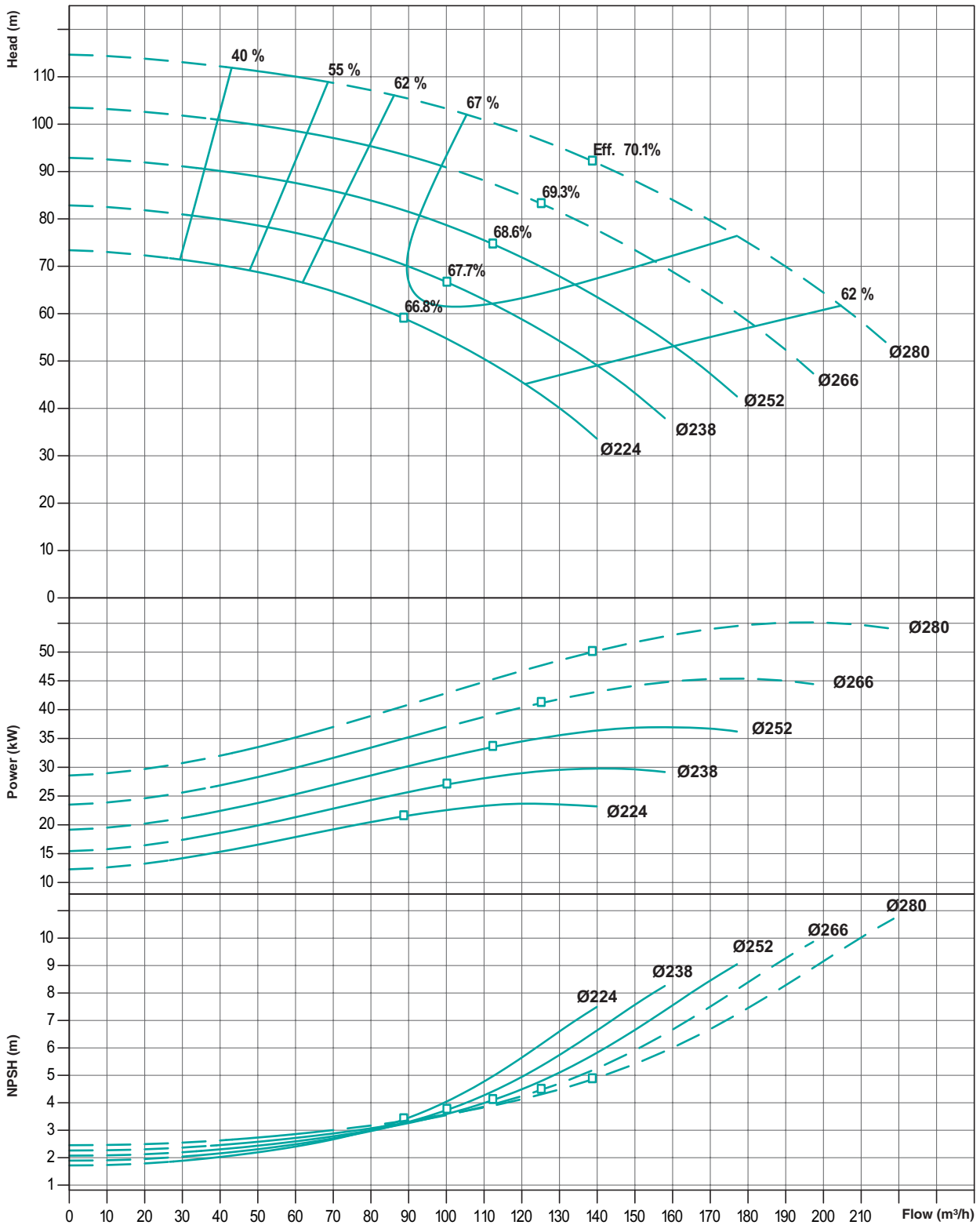

Performance curve tolerances are as per HI : 14.6 / ISO : 9906, Grade 2B

Note : Performance curve are as per specific gravity and viscosity of water.

PERFORMANCE CURVES

Model : **TEC - 4 x 3 x 11**

Speed : **1450 rpm**

Suc x Del (in Inches) : **4 x 3**

Max. Impeller Ø : **280mm**

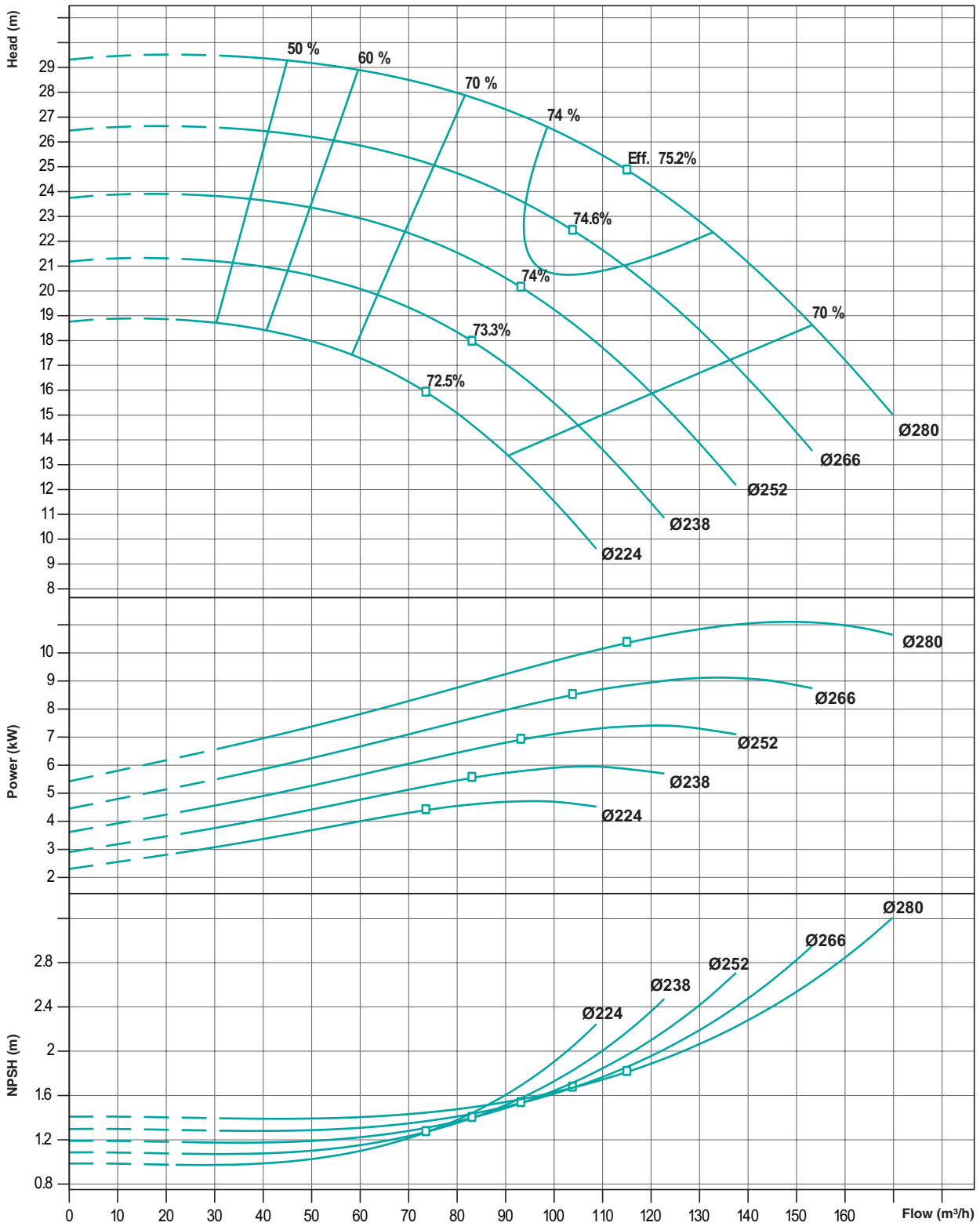

Performance curve tolerances are as per HI : 14.6 / ISO : 9906, Grade 2B

Note : Performance curve are as per specific gravity and viscosity of water.

PERFORMANCE CURVES

Model : **TEC - 4 x 3 x 11**

Speed : **2900 rpm**

Suc x Del (in Inches) : **4 x 3**

Max. Impeller Ø : **280mm**

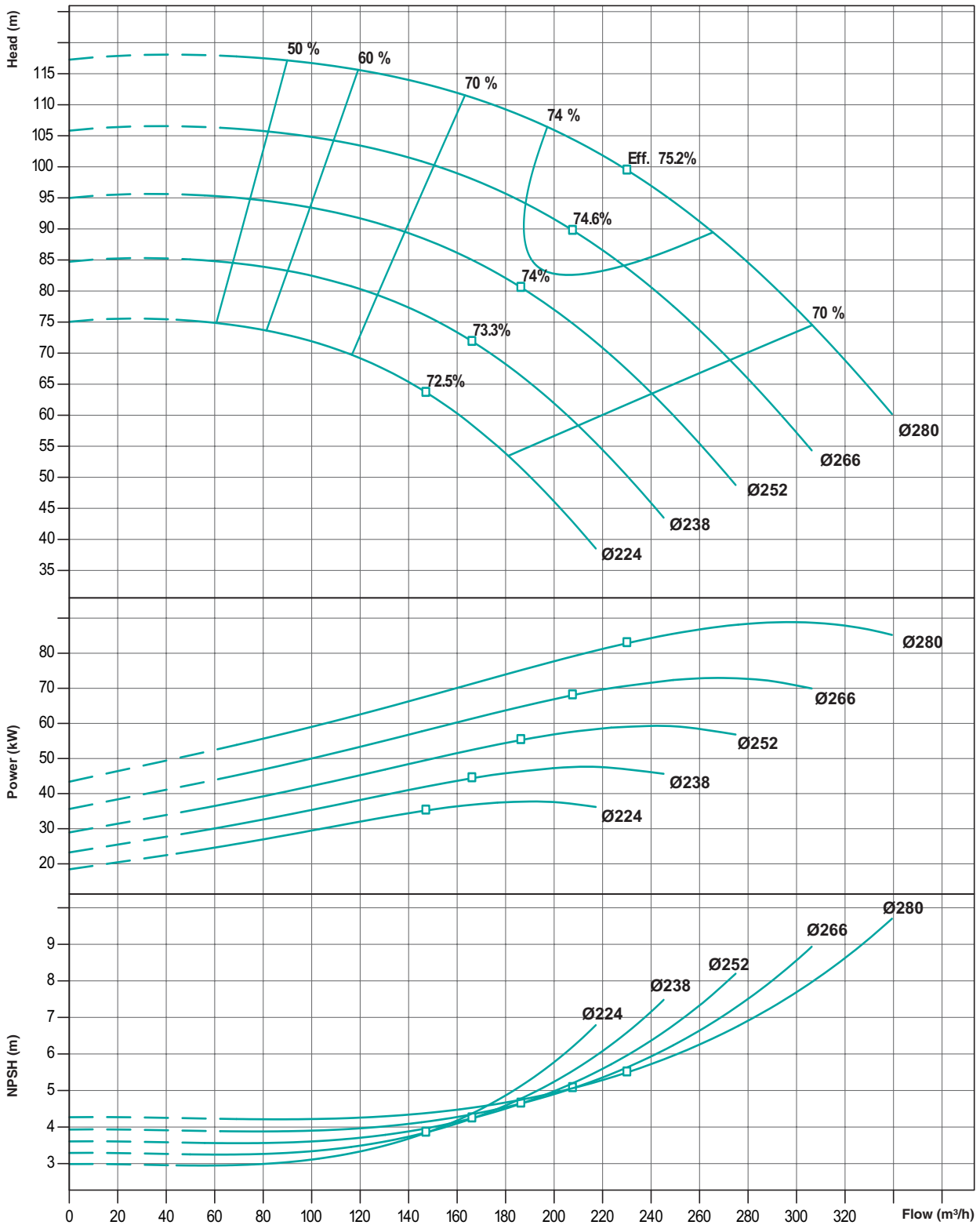

Performance curve tolerances are as per HI : 14.6 / ISO : 9906, Grade 2B

Note : Performance curve are as per specific gravity and viscosity of water.

PERFORMANCE CURVES

Model : **TEC - 3 x 1.5 x 13**

Speed : **1450 rpm**

Suc x Del (in Inches) : **3 x 1.5**

Max. Impeller Ø : **330mm**

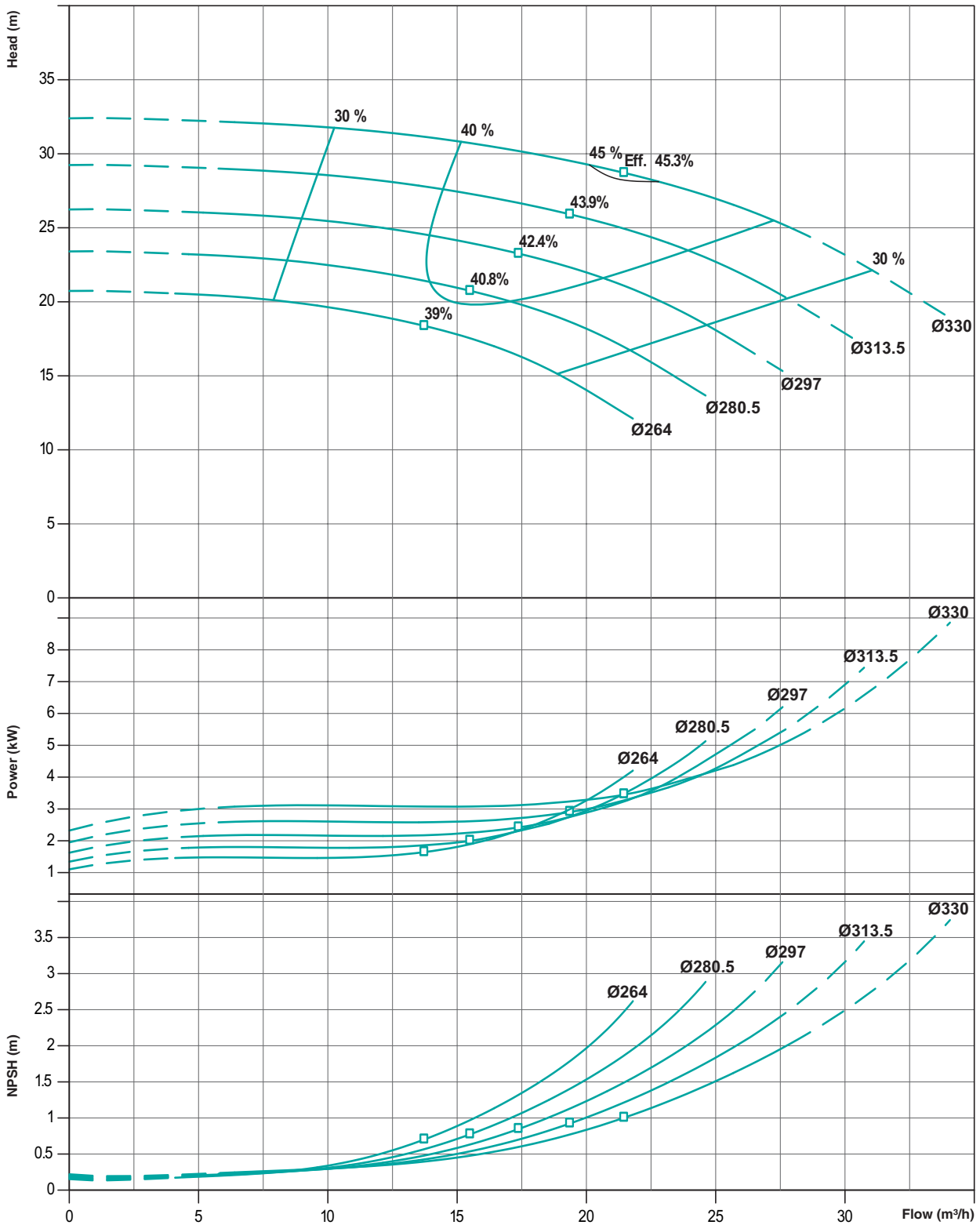

Performance curve tolerances are as per HI : 14.6 / ISO : 9906, Grade 2B

Note : Performance curve are as per specific gravity and viscosity of water.

PERFORMANCE CURVES

Model : **TEC - 3 x 1.5 x 13**

Speed : **2900 rpm**

Suc x Del (in Inches) : **3 x 1.5**

Max. Impeller Ø : **330mm**

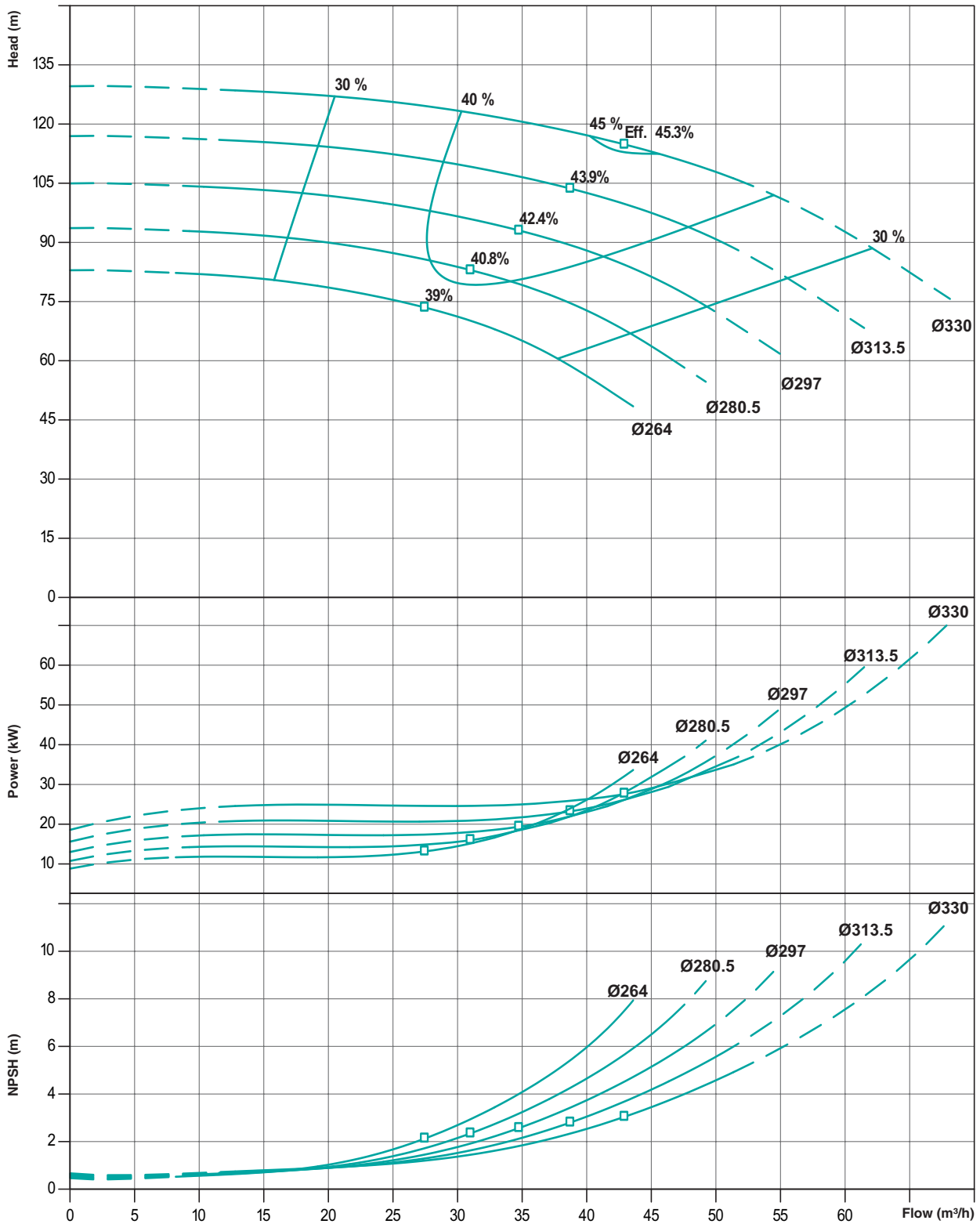

Performance curve tolerances are as per HI : 14.6 / ISO: 9906, Grade 2B

Note : Performance curve are as per specific gravity and viscosity of water.

PERFORMANCE CURVES

Model : **TEC - 3 x 2 x 13**

Speed : **1450 rpm**

Suc x Del (in Inches) : **3 x 2**

Max. Impeller Ø : **330mm**

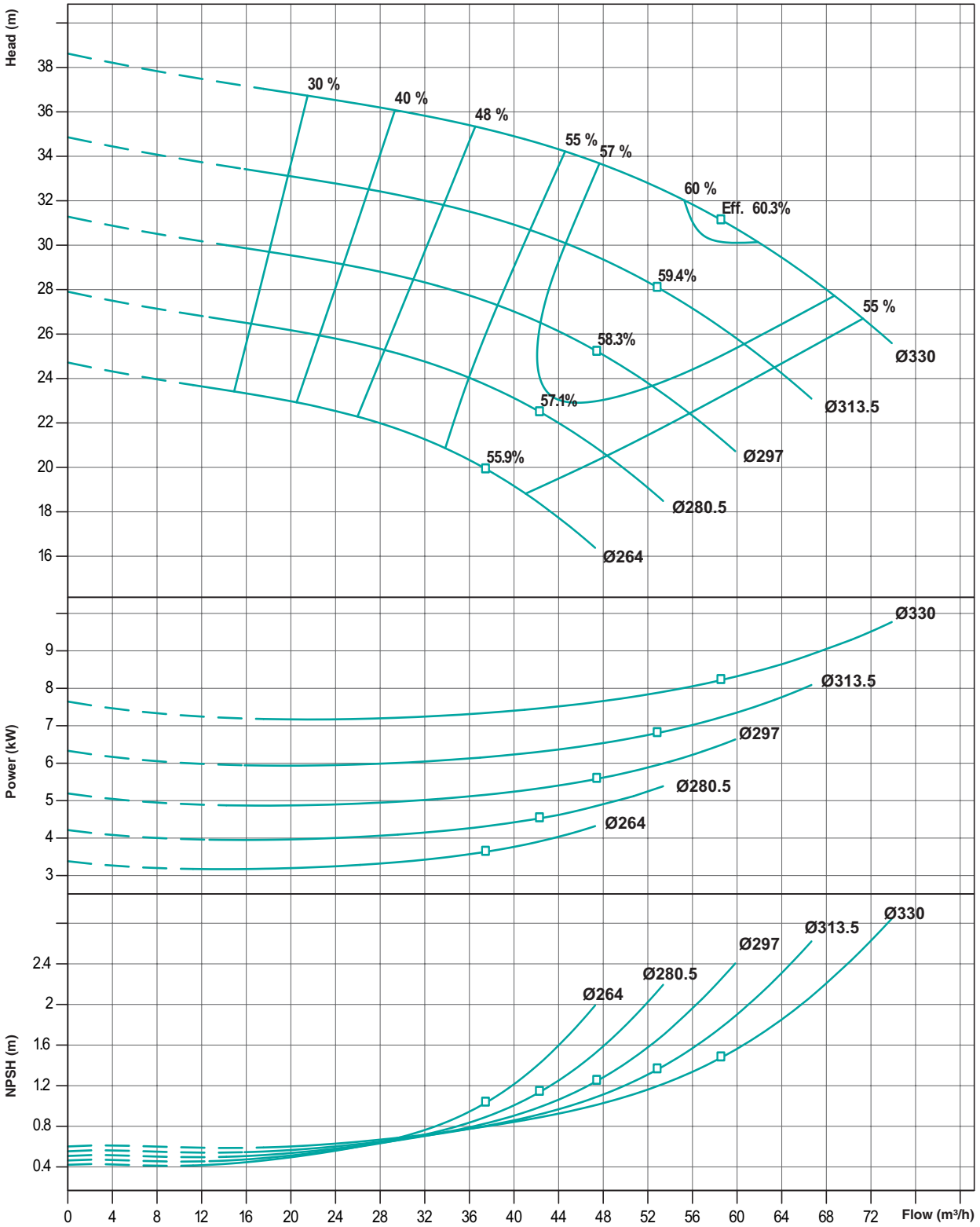

Performance curve tolerances are as per HI : 14.6 / ISO : 9906, Grade 2B

Note : Performance curve are as per specific gravity and viscosity of water.

PERFORMANCE CURVES

Model : **TEC - 3 x 2 x 13**

Speed : **2900 rpm**

Suc x Del (in Inches) : **3 x 2**

Max. Impeller Ø : **330mm**

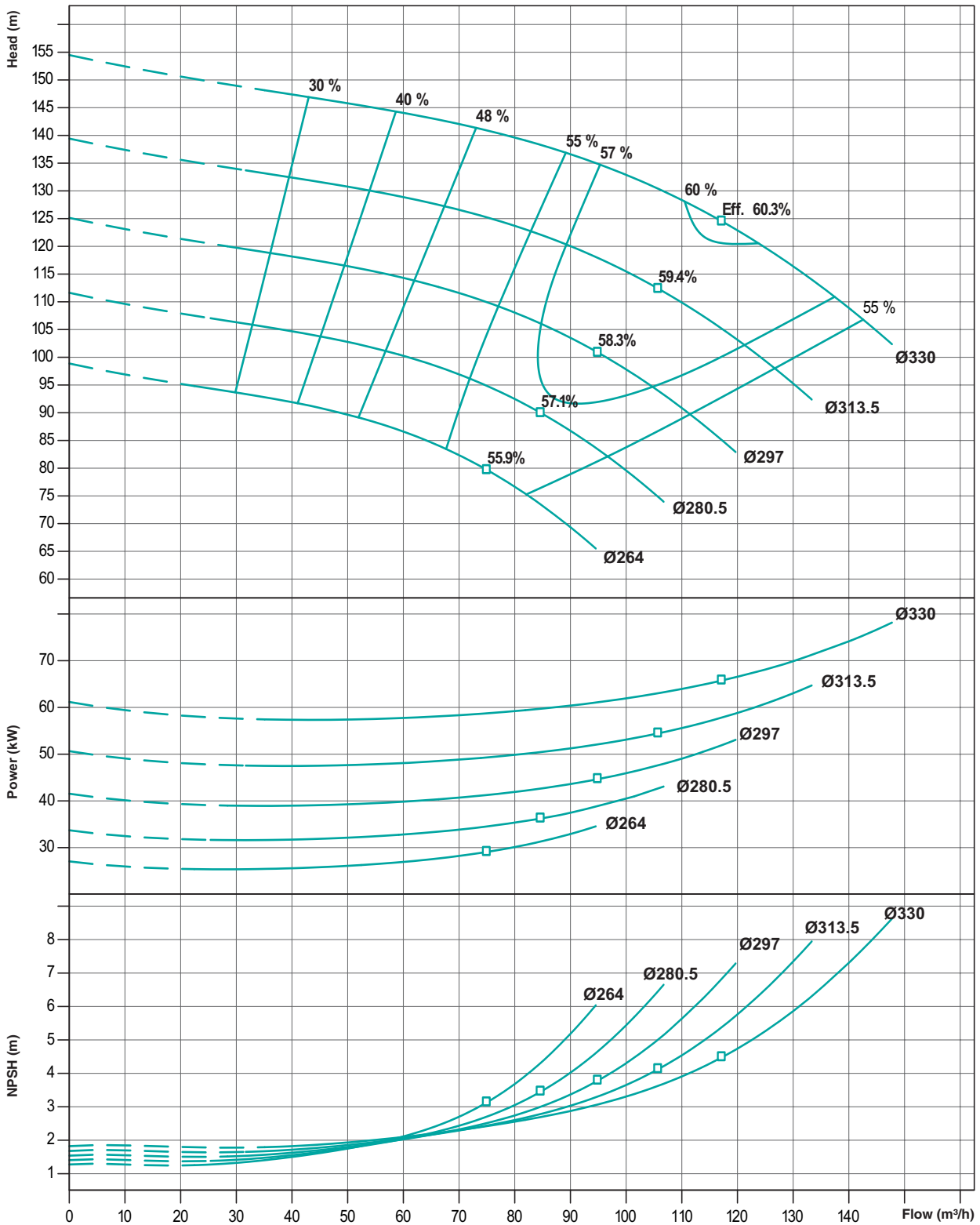

Performance curve tolerances are as per HI : 14.6 / ISO : 9906, Grade 2B

Note : Performance curve are as per specific gravity and viscosity of water.

PERFORMANCE CURVES

Model : **TEC - 4 x 3 x 13**

Speed : **1450 rpm**

Suc x Del (in Inches) : **4 x 3**

Max. Impeller Ø : **330mm**

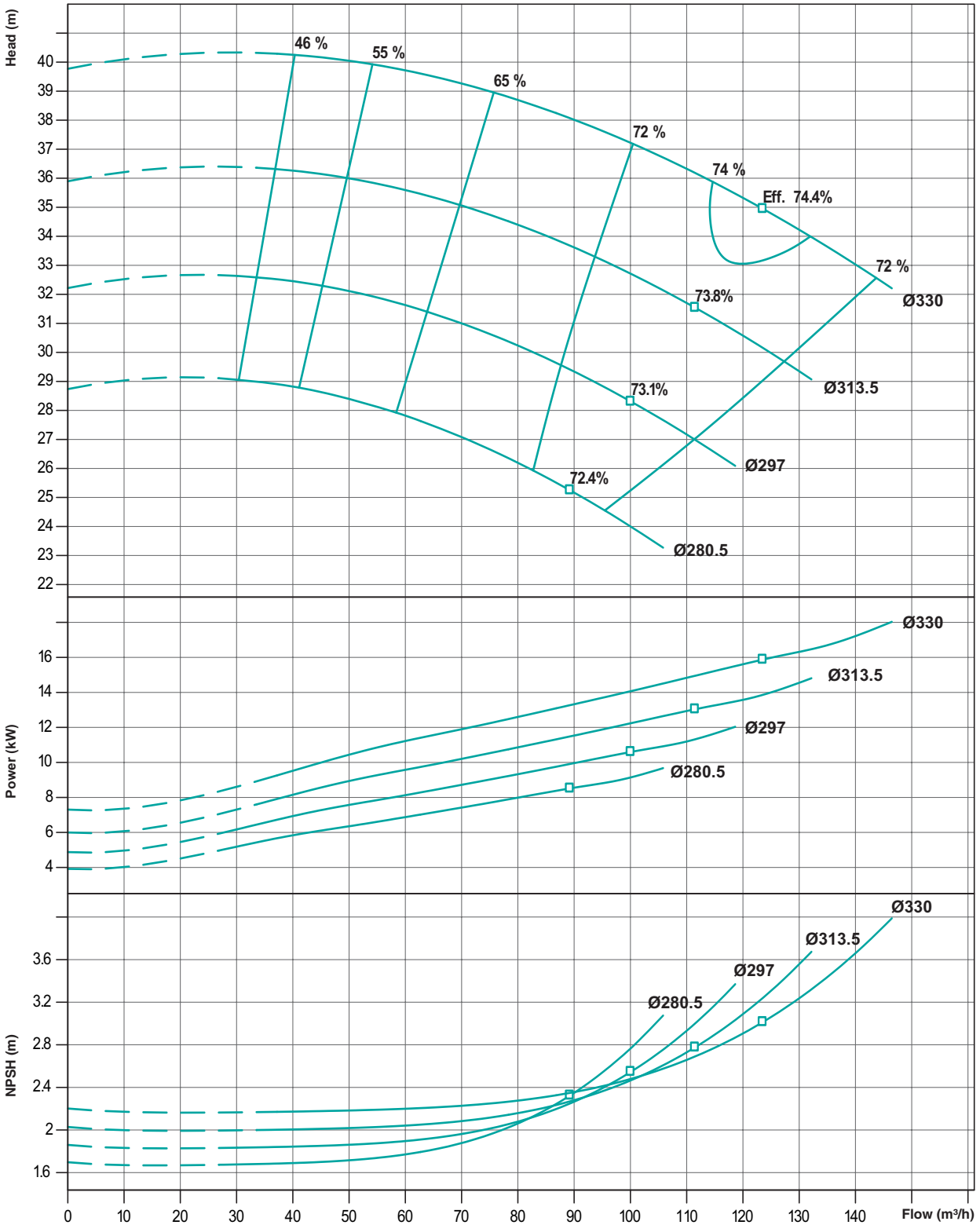

Performance curve tolerances are as per HI : 14.6 / ISO: 9906, Grade 2B

Note : Performance curve are as per specific gravity and viscosity of water.

PERFORMANCE CURVES

Model : **TEC - 6 x 4 x 13**

Speed : **1450 rpm**

Suc x Del (in Inches) : **6 x 4**

Max. Impeller Ø : **330mm**

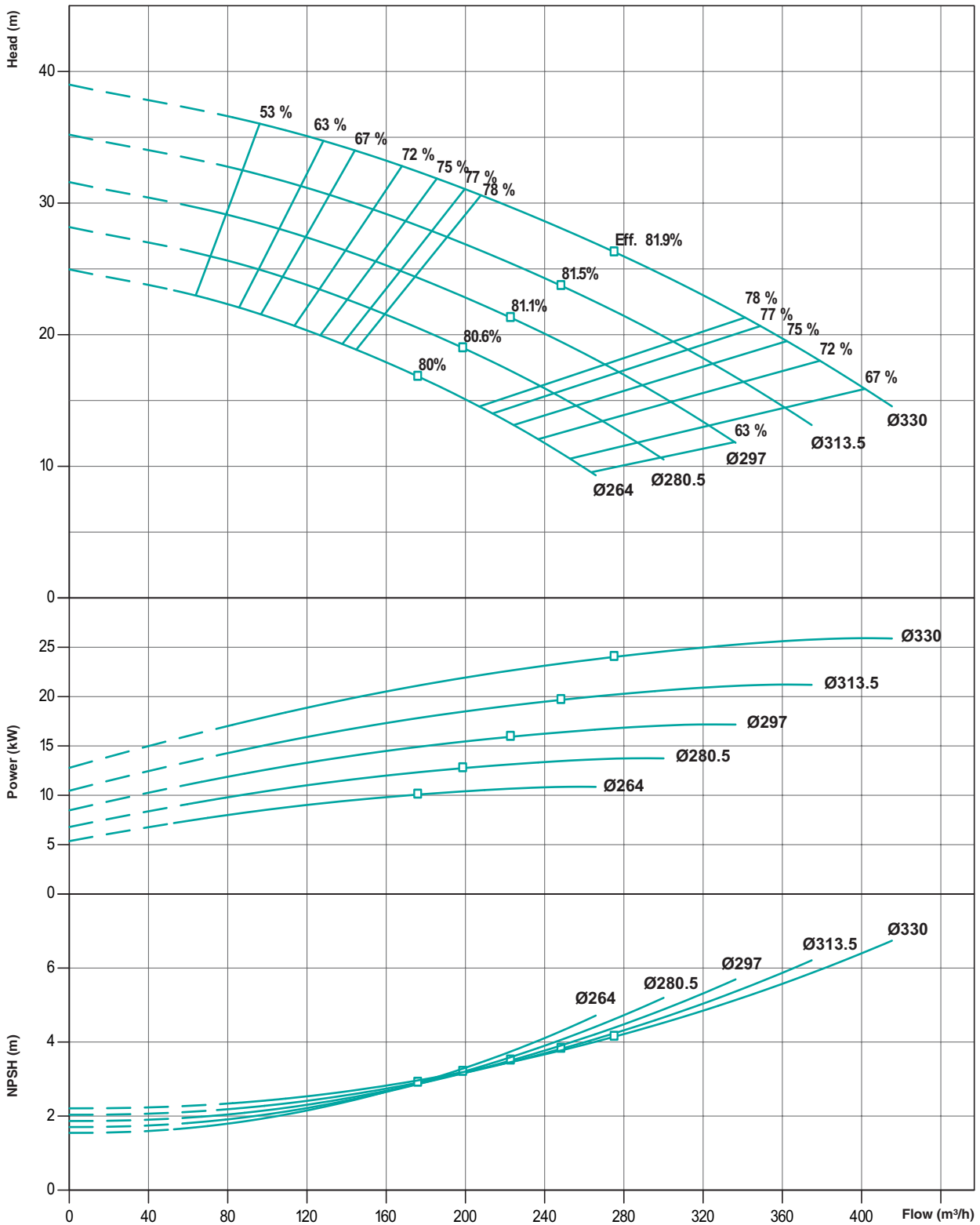

Performance curve tolerances are as per HI : 14.6 / ISO: 9906, Grade 2B

Note : Performance curve are as per specific gravity and viscosity of water.

PERFORMANCE CURVES

Model : **TEC - 8 x 6 x 13**

Speed : **1450 rpm**

Suc x Del (in Inches) : **8 x 6**

Max. Impeller Ø : **330mm**

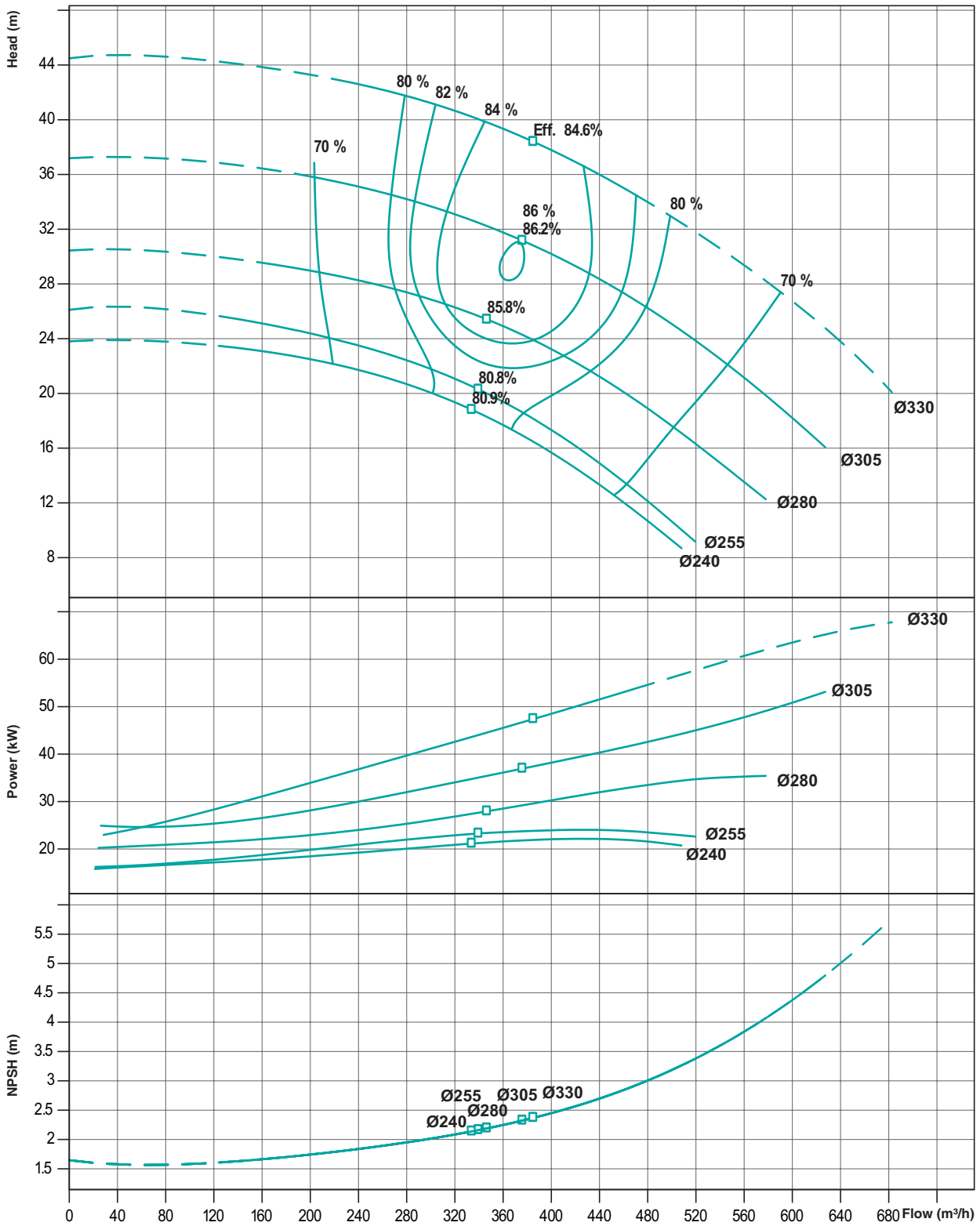

Performance curve tolerances are as per HI : 14.6 / ISO: 9906, Grade 2B

Note : Performance curve are as per specific gravity and viscosity of water.

PERFORMANCE CURVES

Model : **TEC - 8 x 6 x 15**

Speed : **1450 rpm**

Suc x Del (in Inches) : **8 x 6**

Max. Impeller Ø : **380mm**

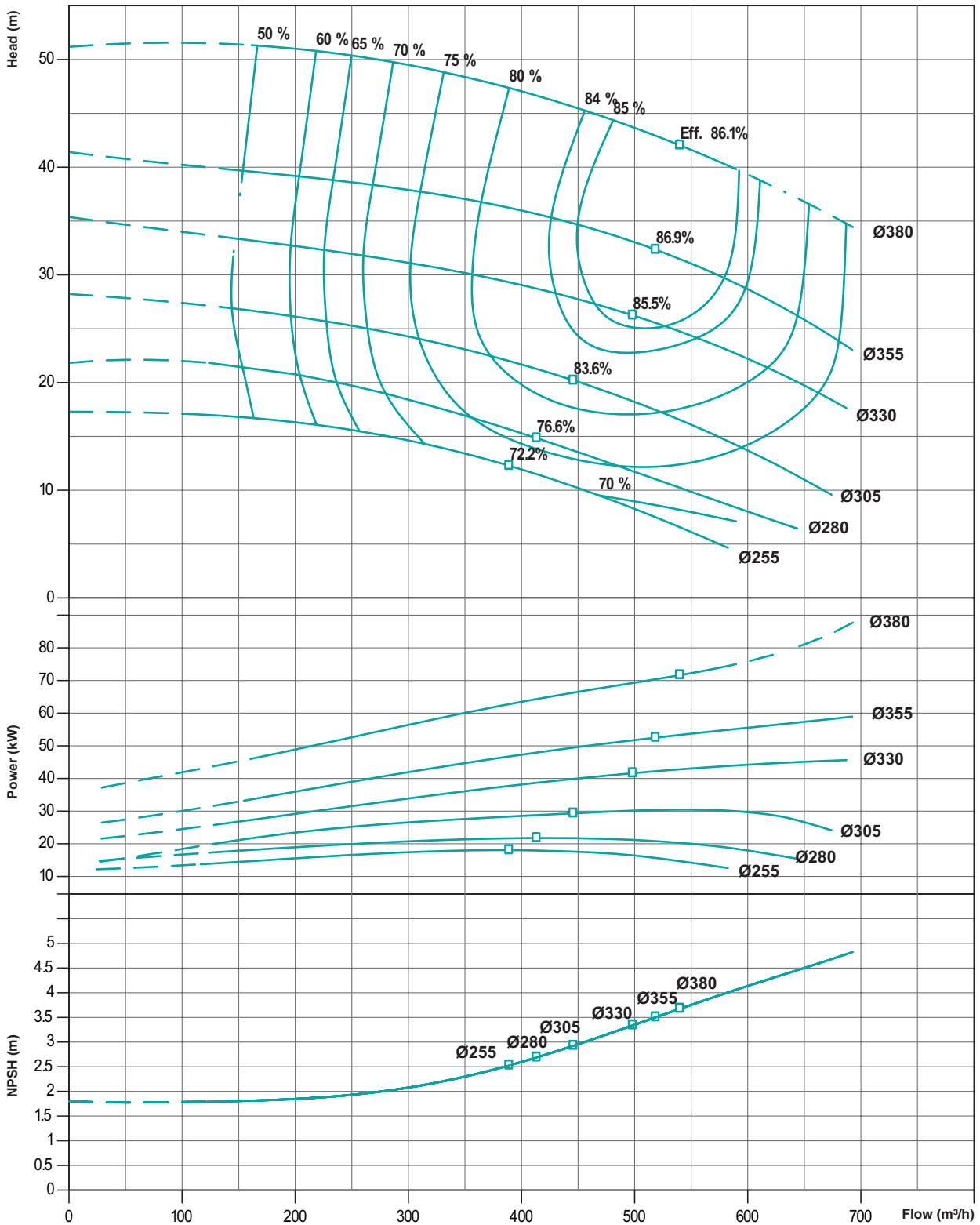

Performance curve tolerances are as per HI : 14.6 / ISO : 9906, Grade 2B

Note : Performance curve are as per specific gravity and viscosity of water.

PERFORMANCE CURVES

Model : **TEC - 10 x 8 x 15**

Speed : **1450 rpm**

Suc x Del (in Inches) : **10 x 8**



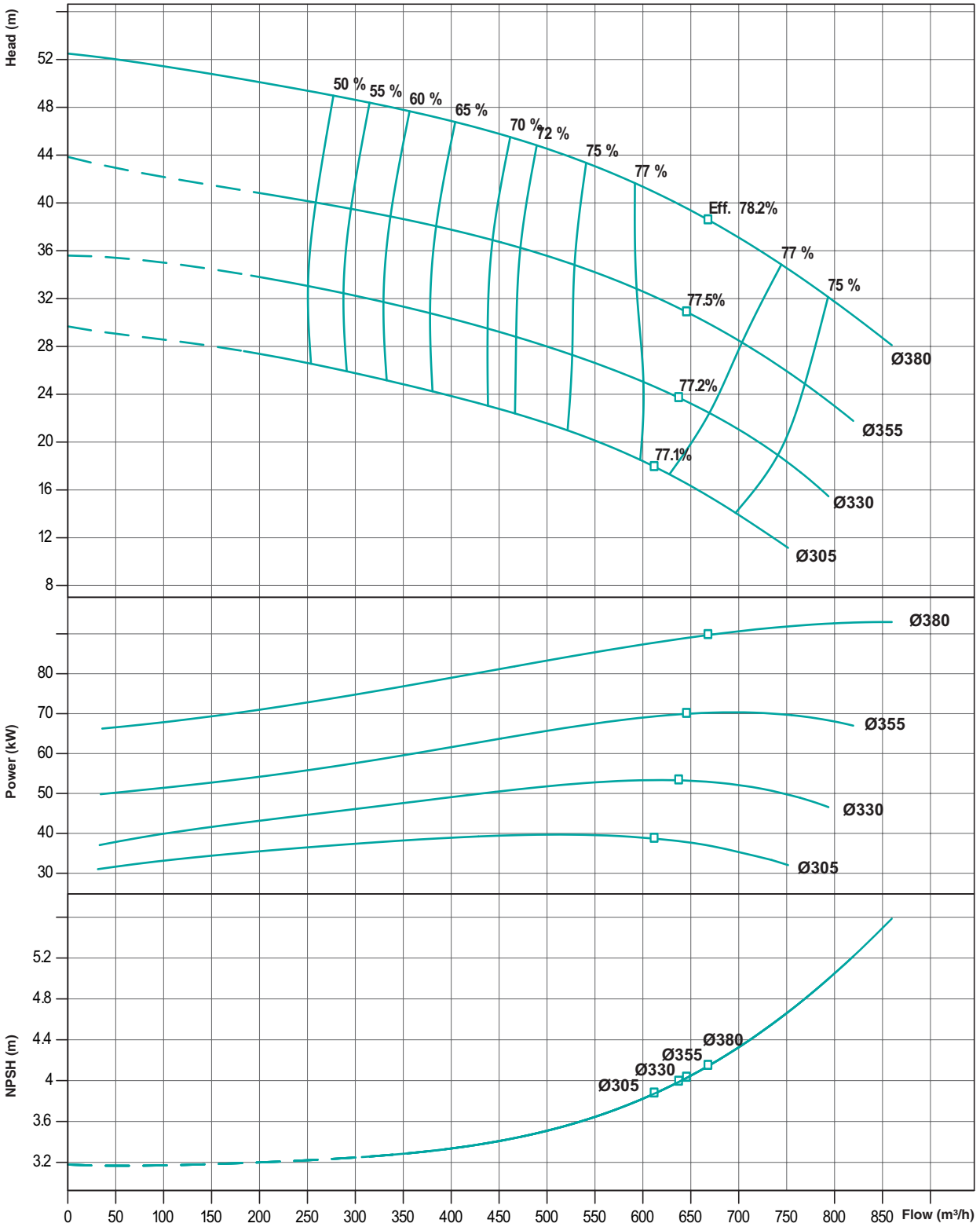





















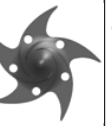
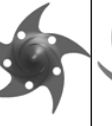
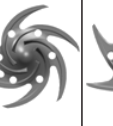

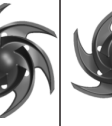
Max. Impeller Ø : **380mm**

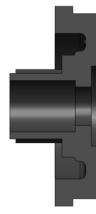
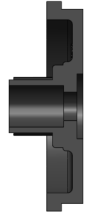
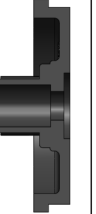

































Performance curve tolerances are as per HI : 14.6 / ISO : 9906, Grade 2B

Note : Performance curve are as per specific gravity and viscosity of water.

INTERCHANGEABILITY CHART

PART NAME	1.5 x 1 x 6 (40 x 25 x 150)	3 x 1.5 x 6 (80 x 40 x 150)	3 x 2 x 6 (80 x 50 x 150)	1.5 x 1 x 8 (40 x 25 x 200)	3 x 1.5 x 8 (80 x 40 x 200)	2 x 1 x 10 (50 x 25 x 250)	3 x 1.5 x 8.5 (80 x 40 x 215)	3 x 2 x 8.5 (80 x 50 x 215)	4 x 3 x 8.5 (100 x 80 x 215)	6 x 4 x 8.5 (150 x 100 x 215)
CASING										
IMPELLER										
STUFFING BOX										
CONNECTING FRAME										
BEARING FRAME ASSEMBLY										

INTERCHANGEABILITY CHART

PART NAME	3 x 1.5 x 11 (80 x 40 x 280)	3 x 2 x 11 (80 x 50 x 280)	4 x 3 x 11 (100 x 80 x 280)	3 x 1.5 x 13 (80 x 40 x 330)	3 x 2 x 13 (80 x 50 x 330)	4 x 3 x 13 (100 x 80 x 330)	6 x 4 x 13 (150 x 100 x 330)	8 x 6 x 13 (200 x 150 x 330)	8 x 6 x 15 (200 x 150 x 380)	10 x 8 x 13 (250 x 200 x 330)	10 x 8 x 15 (250 x 200 x 380)
CASING											
IMPELLER											
STUFFING BOX											
CONNECTING FRAME											
BEARING FRAME ASSEMBLY											

DETAILS OF STANDARD COMPONENTS

SHAFT AND BEARING DATA	FRAME SIZE		
	I	II	III
SHAFT DIAMETER (mm)			
At Coupling	Ø 22.23	Ø 28.58	Ø 60.33
At 'NDE' Bearings	Ø 35	Ø 55	Ø 85
At 'DE' Bearings	Ø 30	Ø 45	Ø 75
Between bearings	Ø 40.13	Ø 60	Ø 92.1
Under Sleeve	Ø 27.97	Ø 45	Ø 60
STUFFING BOX DETAILS (mm)			
Shaft sleeve outer diameter	Ø 35	Ø 55	Ø 70
Stuffing Box Bore Diameter	Ø 50.5	Ø 74.5	Ø 94.5
Stuffing Box Depth	57	67	91
SHAFT LENGTH (mm)			
Impeller end of shaft to 'NDE' Bearing	165.95	218.25	297
Between bearings	67.4	128.75	172
'DE' Bearing to Coupling end	116	150	247.5
BEARINGS			
'NDE'	6307	6311	6317
'DE'	3306	7309 (2 Bearings back to back)	3315
KEYWAY AT COUPLING (mm)			
Width	4.76	6.35	15.88
Depth	2.38	3.18	9.15
Length	40	50	90
SHAFT THREAD AT IMPELLER	M20X1.5 RH	M24X2 RH	M45X1.5 RH

BARE SHAFT PUMP - MOUNTING DIMENSION

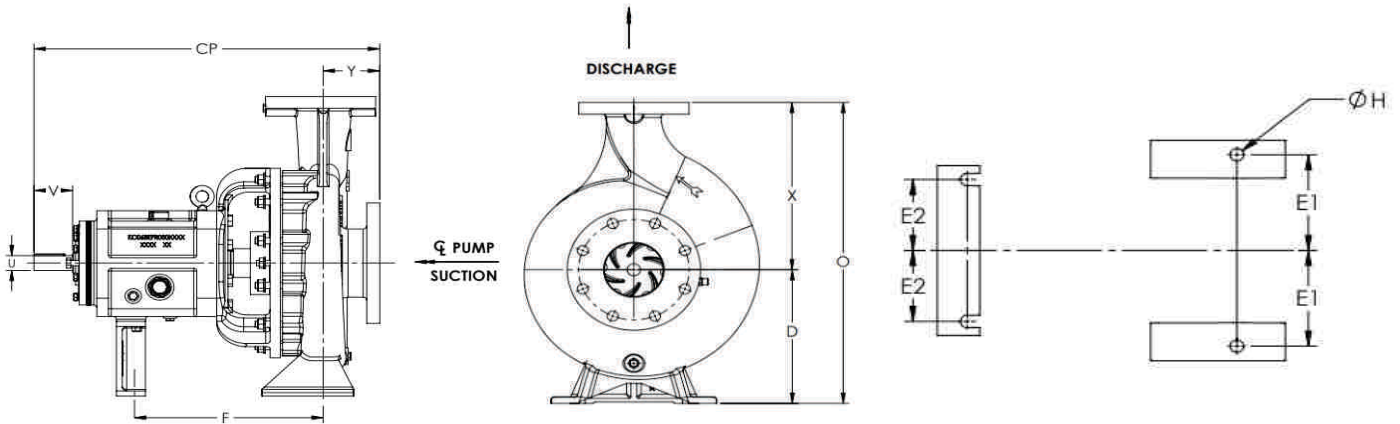

Pump Size - Suc x Del / Imp Ø (mm) (inch)	Suction size (mm)	Delivery size (mm)	Mounting Dimension (mm)										
			CP	D	ZE 1	ZE 2	F	H	X	Y	O	V	U (Dia.)
40 x 25 x 150 (1.5 x 1 x 6)	40	25	445	133	152	0	184	16	165	102	298	51	22.23
80 x 40 x 150 (3 x 1.5 x 6)	80	40	445	133	152	0	184	16	165	102	298	51	22.23
80 x 50 x 150 (3 x 2 x 6)	80	50	445	133	152	0	184	16	165	102	298	51	22.23
40 x 25 x 200 (1.5 x 1 x 8)	40	25	445	133	152	0	184	16	165	102	298	51	22.23
80 x 40 x 200 (3 x 1.5 x 8)	80	40	445	133	152	0	184	16	165	102	298	51	22.23
50 x 25 x 250 (2 x 1 x 10)*	50	25	597	210	248	184	318	16	216	102	425	67	28.58
80 x 40 x 215 (3 x 1.5 x 8.5)*	80	40	597	210	248	184	318	16	216	102	425	67	28.58
80 x 50 x 215 (3 x 2 x 8.5)*	80	50	597	210	248	184	318	16	242	102	450	67	28.58
100 x 80 x 215 (4 x 3 x 8.5)*	100	80	597	210	248	184	318	16	280	102	490	67	28.58
150 x 100 x 215 (6 x 4 x 8.5)	150	100	597	210	248	184	318	16	280	102	490	67	28.58
80 x 40 x 280 (3 x 1.5 x 11)*	80	40	597	254	248	184	318	16	267	102	520	67	28.58
80 x 50 x 280 (3 x 2 x 11)*	80	50	597	254	248	184	318	16	292	102	546	67	28.58
100 x 80 x 280 (4 x 3 x 11)*	100	80	597	254	248	184	318	16	318	102	572	67	28.58
80 x 40 x 330 (3 x 1.5 x 13)*	80	40	597	254	248	184	318	16	266	102	520	67	28.58
80 x 50 x 330 (3 x 2 x 13)	80	50	597	254	248	184	318	16	292	102	546	67	28.58
100 x 80 x 330 (4 x 3 x 13)	100	80	597	254	248	184	318	16	318	102	572	67	28.58
150 x 100 x 330 (6 x 4 x 13)	150	100	597	254	248	184	318	16	343	102	597	67	28.58
125 x 100 x 250 (5 x 4 x 10)*	125	100	597	254	248	184	318	16	343	102	597	67	28.58
200 x 150 x 330 (8 x 6 x 13)*	200	150	860	368	406	229	476	22	406	152	775	102	60.33
200 x 150 x 380 (8 x 6 x 15)	200	150	860	368	406	229	476	22	457	152	826	102	60.33
250 x 200 x 380 (10 x 8 x 15)	250	200	860	368	406	229	476	22	483	152	851	102	60.33

* Optional : Cooling jacket models.

Note : All Dimensions are in mm, Unless Otherwise Specified

END SUCTION LIGHT CHEMICAL & PROCESS LOW FLOW PUMPS TEC - IL SERIES - NON-STANDARD (50Hz)

The TEC-IL series of low flow process pumps are horizontal, end-suction, single-stage pumps designed for reliability and safety. They feature a semi-open scallop-cut impeller that is ideal for pumping low-viscosity fluids with suspended solids. This impeller design also simplifies cleaning and maintenance. The TEC-IL series offers a variety of material options to suit different applications.

Technical data

Head Range	5 - 64m
Flow Range	2 - 27.6m ³ /h
Speed	1450 / 2850 rpm
Impeller Type	Semi Open Impeller
Outlet Size	3/4" - 1 1/4"
Power Range	0.37 - 4.9kW
Maximum Liquid Temperature	-10°C to 90°C
Shaft Seal	Standard : Gland Packing
	Optional : Mechanical Seal
Bearing Lubrication	Oil
Flange Standard	DIN / ANSI
Maximum working Pressure	3-6 bar



Applications

- Chemical dosing and injection
- Additive and solvent transfer
- Brine Transfer
- Pharma and food industry
- Beverage & Distilled liquid transfer
- Water Treatment Plants

Design Features

- Fitted with non clog semi open impeller
- Robust shaft and bearing design
- Gland packing or mechanical seal
- Different material options
- Modular design helps reduce spare parts inventory

EXPLODED VIEW

GLAND PACKING CONSTRUCTION

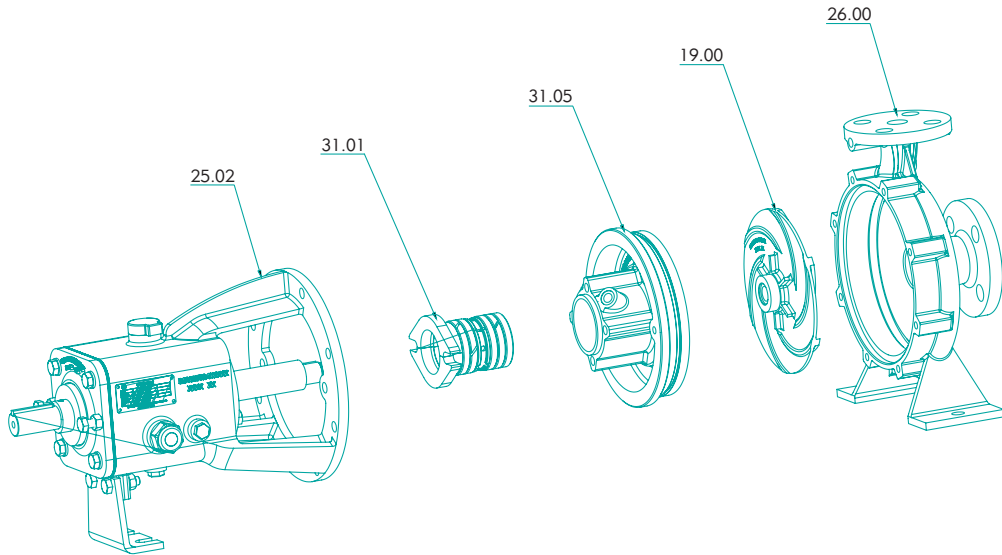

MECHANICAL SEAL CONSTRUCTION

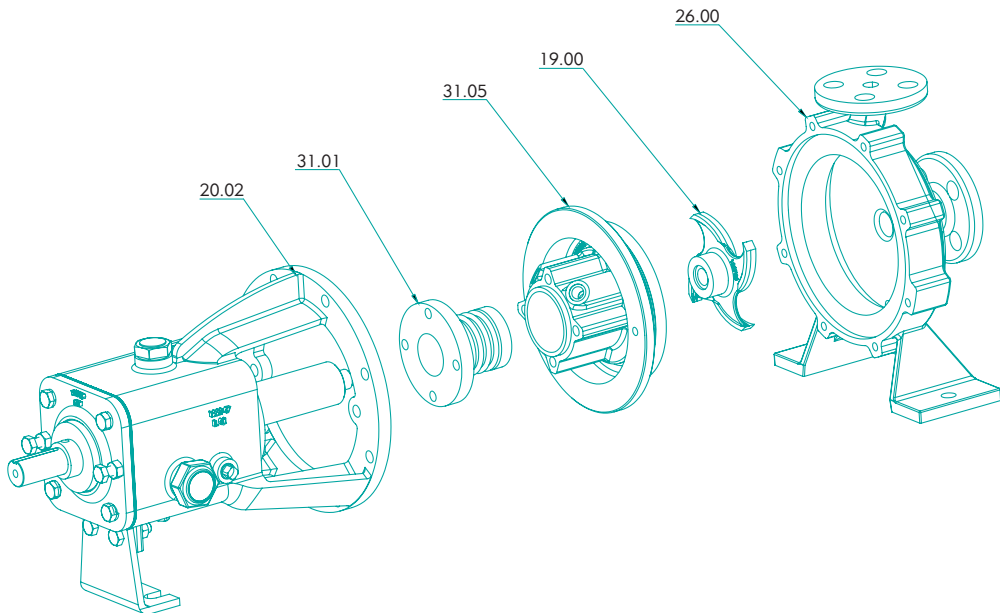

PART NO	PART NAME
26.00	CASING
19.00	IMPELLER
31.05	STUFFING BOX
31.01	PACKING / MECHANICAL SEAL
25.02	CONNECTING FRAME
20.02	BEARING FRAME

CROSS SECTIONAL DRAWING

GLAND PACKING CONSTRUCTION

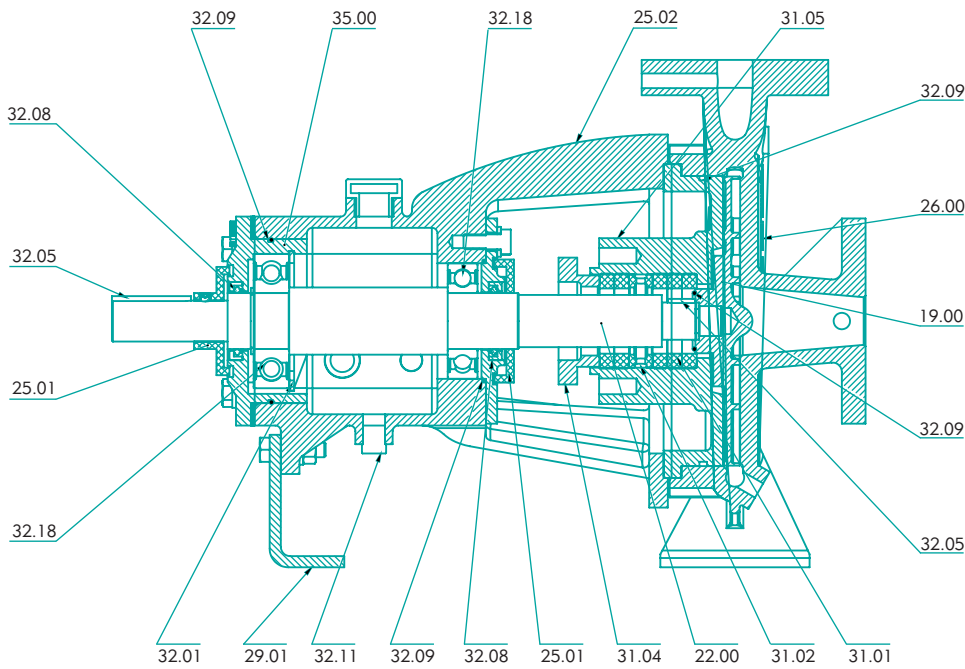

MECHANICAL SEAL CONSTRUCTION

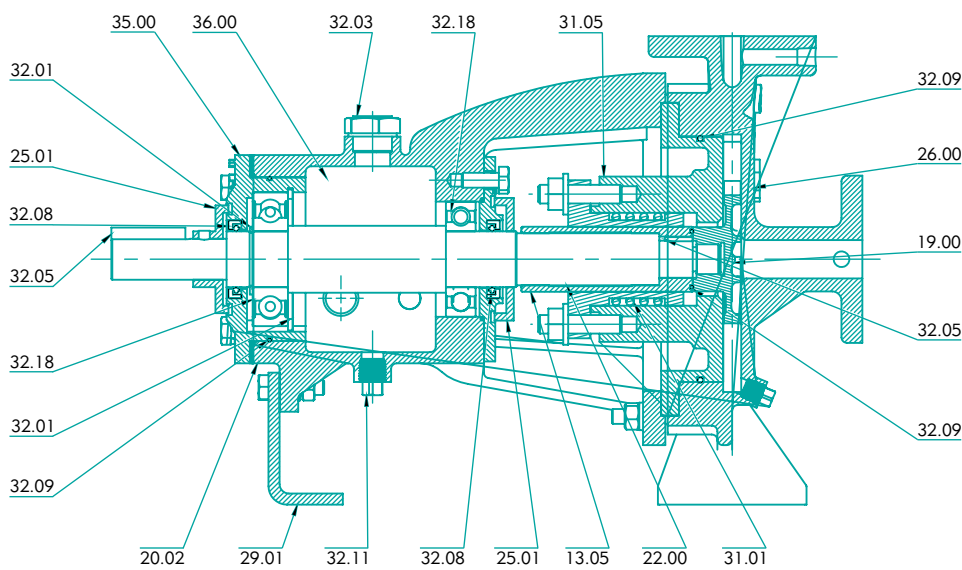

Part No	Part Name
32.09	O - RING
26.00	CASING
19.00	IMPELLER
32.05	KEY
31.01	PACKING / MECHANICAL SEAL
31.02	LANTERN RING
22.00	PUMP SHAFT
31.04	GLAND
13.05	SLEEVE
25.01	DEFLECTOR
32.08	OIL SEAL
29.01	FRAME SUPPORT
32.11	PLUG
20.02	BEARING FRAME
32.01	CIRCLIP
32.18	BEARING
35.00	BEARING HOUSING
25.02	CONNECTING FRAME
31.05	STUFFING BOX
32.03	OIL BREATHER
36.00	OIL CHAMBER

PERFORMANCE CURVES

Model : **TEC-IL - 1 x 0.75 x 6**

Speed : **1450 rpm**

Suc x Del (in Inches) : **1 x 0.75**

Max. Impeller Ø : **150mm**

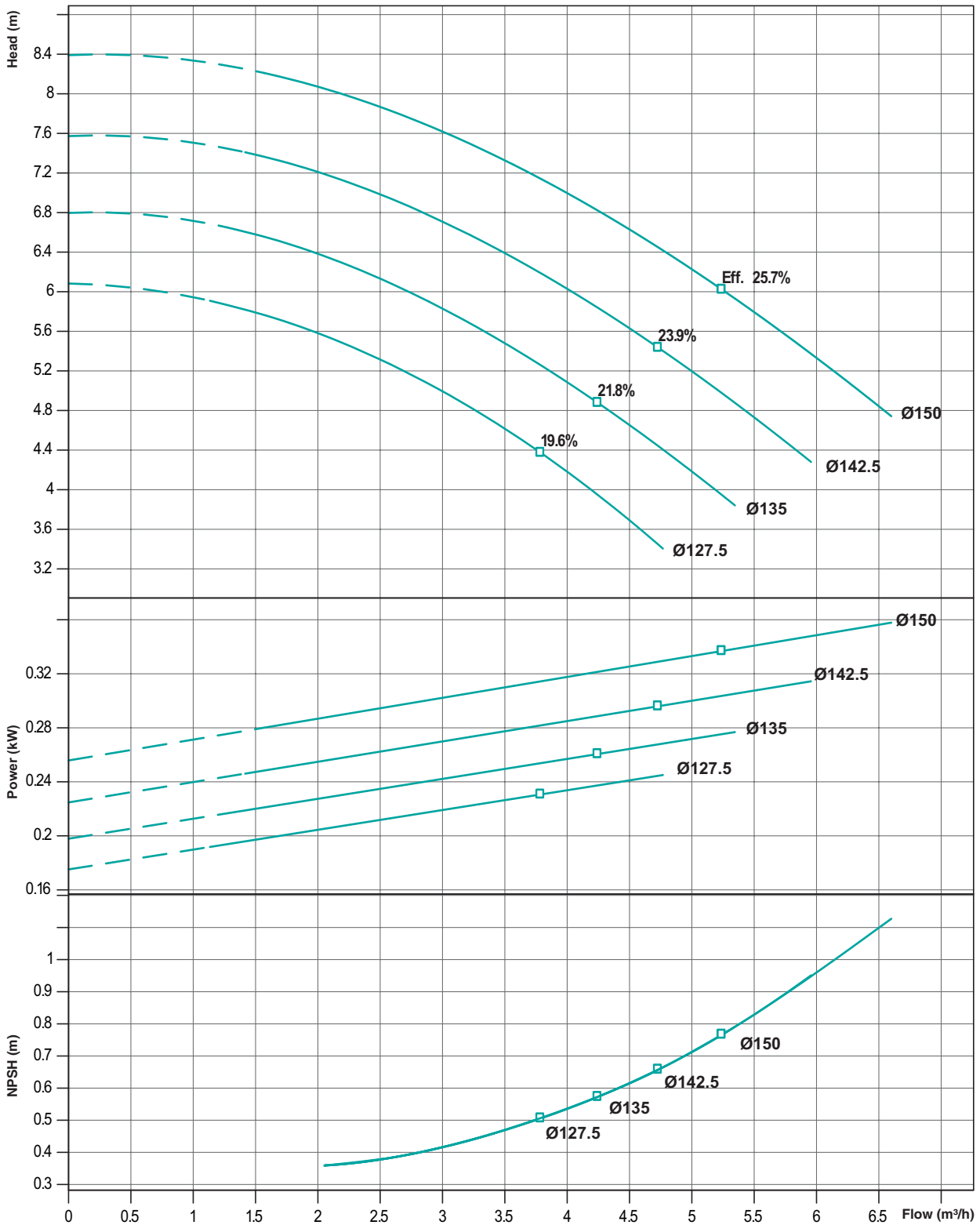

Performance curve tolerances are as per HI : 14.6 / ISO: 9906, Grade 2B

Note : Performance curve are as per specific gravity and viscosity of water.

PERFORMANCE CURVES

Model : **TEC-IL - 1 x 0.75 x 6**

Speed : **2900 rpm**

Suc x Del (in Inches) : **1 x 0.75**

Max. Impeller Ø : **150mm**

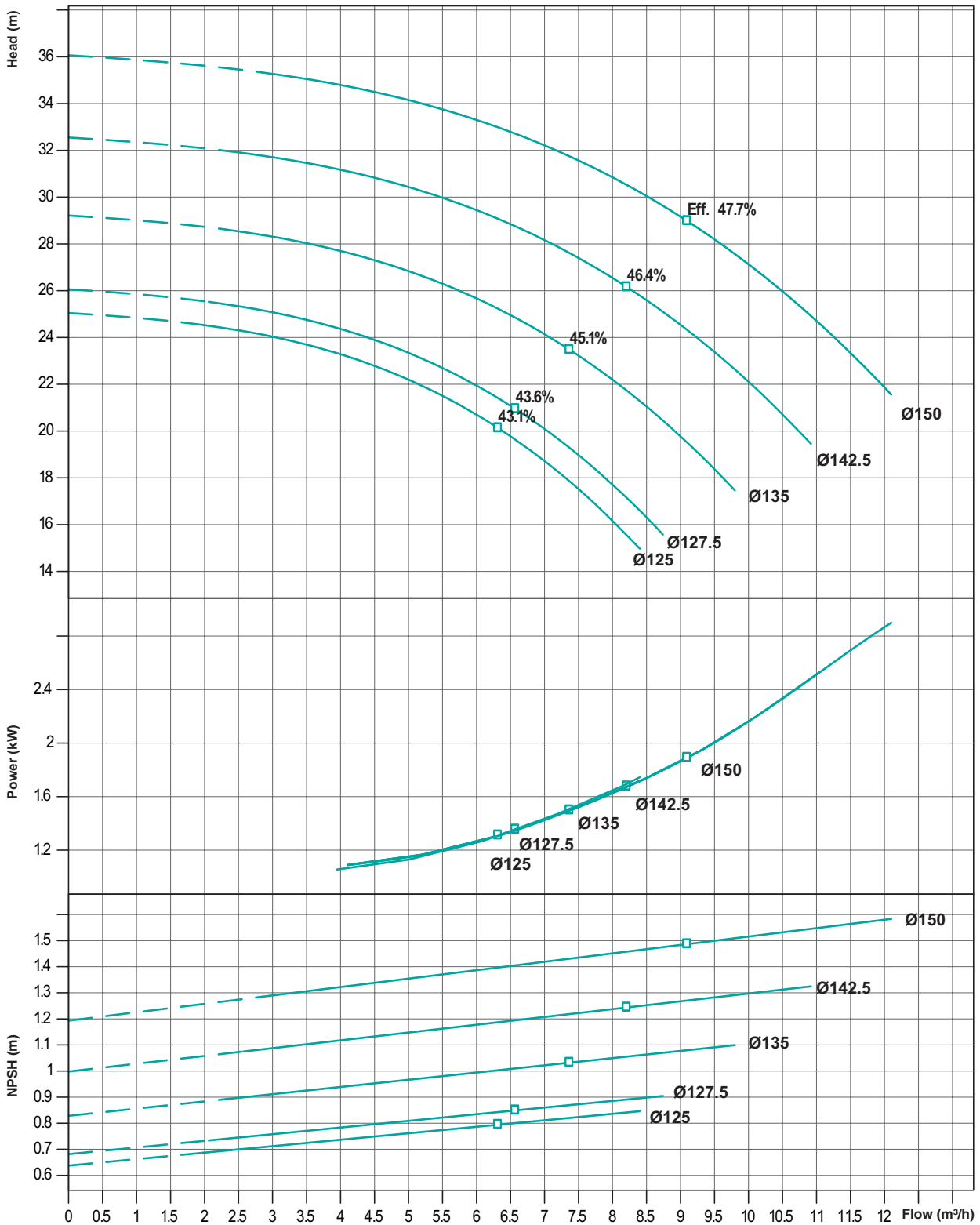

Performance curve tolerances are as per HI : 14.6 / ISO: 9906, Grade 2B

Note : Performance curve are as per specific gravity and viscosity of water.

PERFORMANCE CURVES

Model : **TEC-IL - 1.25 x 1 x 6**

Speed : **1450 rpm**

Suc x Del (in Inches) : **1.25 x 1**

Max. Impeller Ø : **155mm**

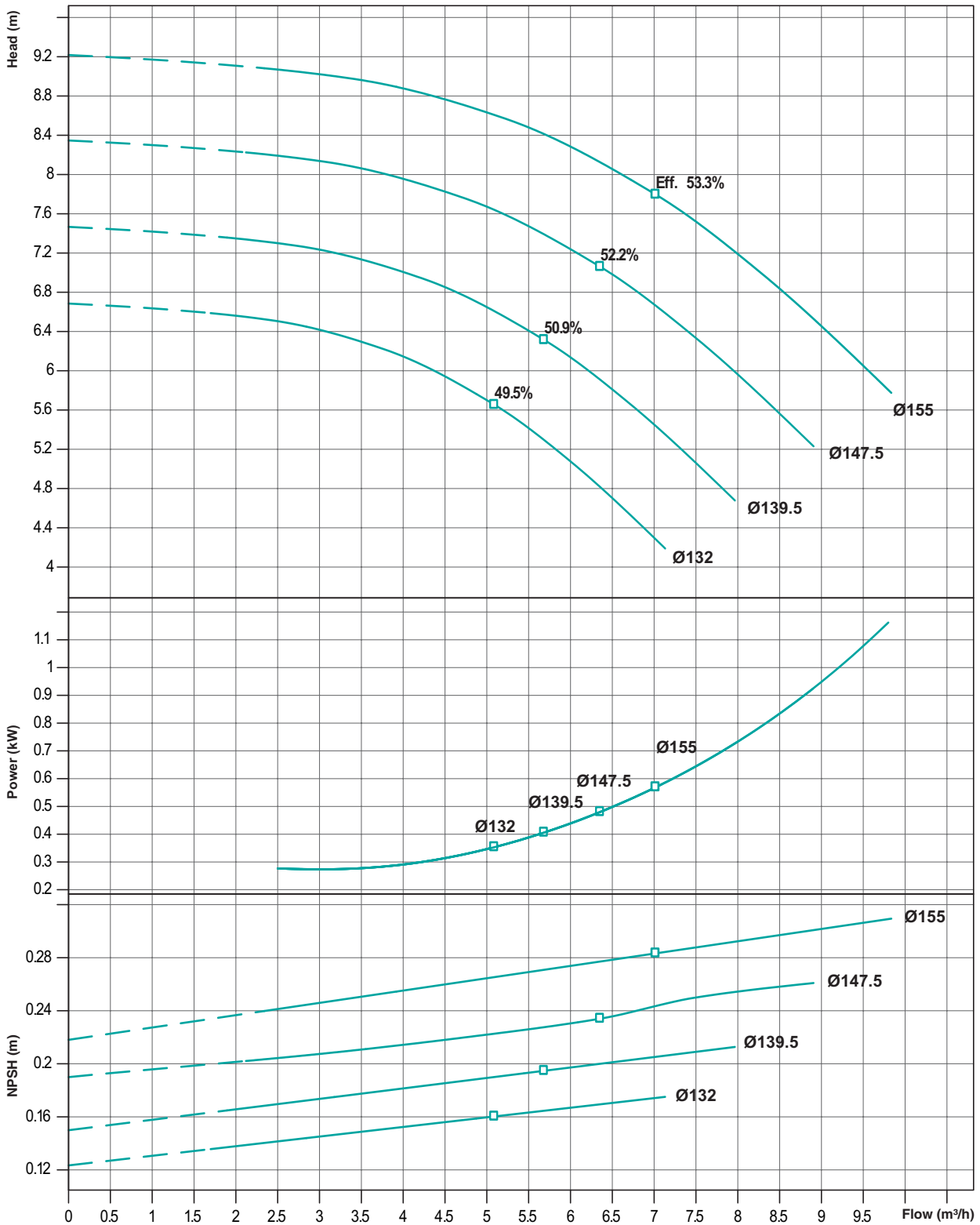

Performance curve tolerances are as per HI : 14.6 / ISO: 9906, Grade 2B

Note : Performance curve are as per specific gravity and viscosity of water.

PERFORMANCE CURVES

Model : **TEC-IL - 1.25 x 1 x 6**

Speed : **2900 rpm**

Suc x Del (in Inches) : **1.25 x 1**

Max. Impeller Ø : **155mm**

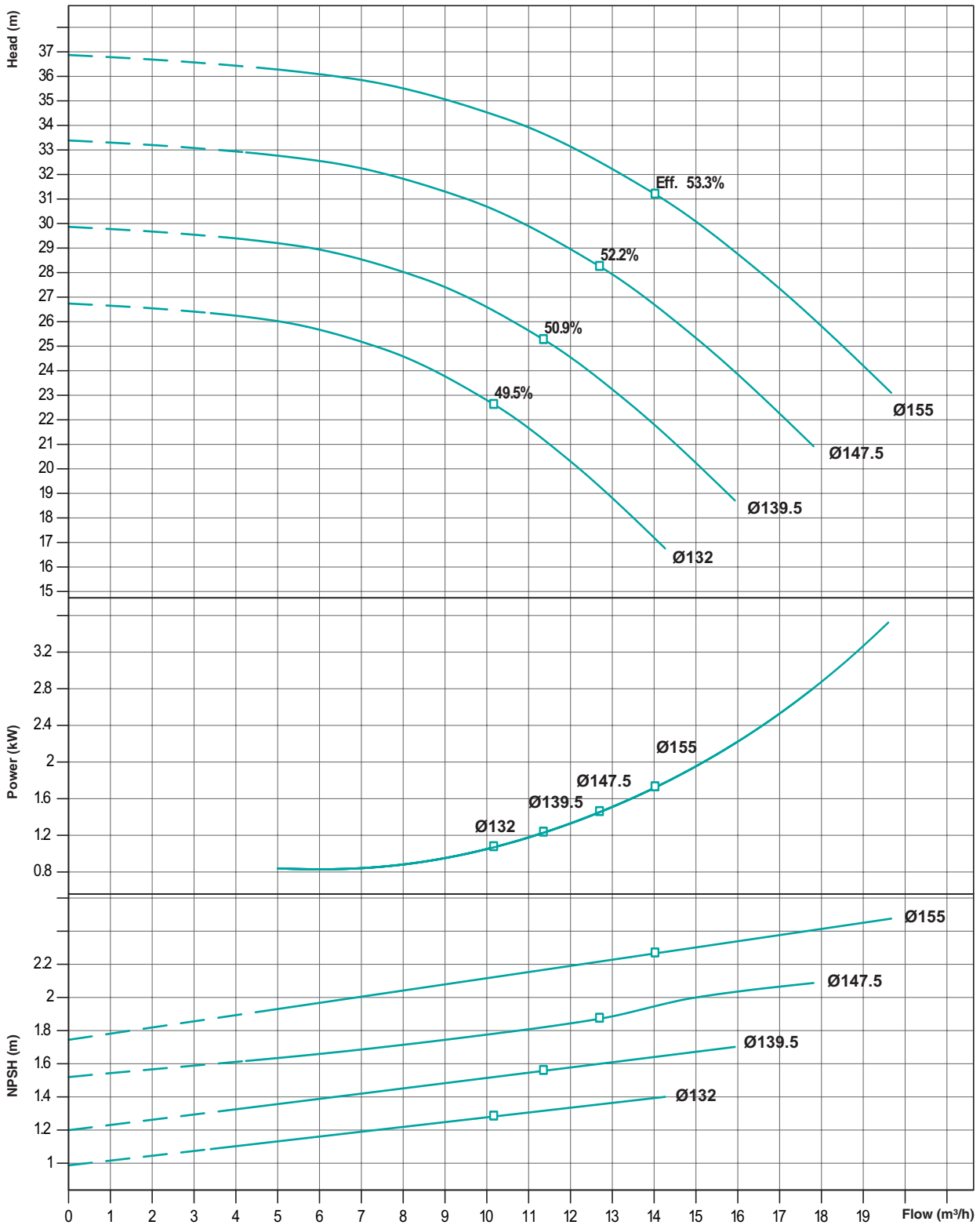

Performance curve tolerances are as per HI : 14.6 / ISO: 9906, Grade 2B

Note : Performance curve are as per specific gravity and viscosity of water.

PERFORMANCE CURVES

Model : **TEC-IL - 1.5 x 1.25 x 6**

Speed : **1450 rpm**

Suc x Del (in Inches) : **1.5 x 1.25**

Max. Impeller Ø : **155mm**

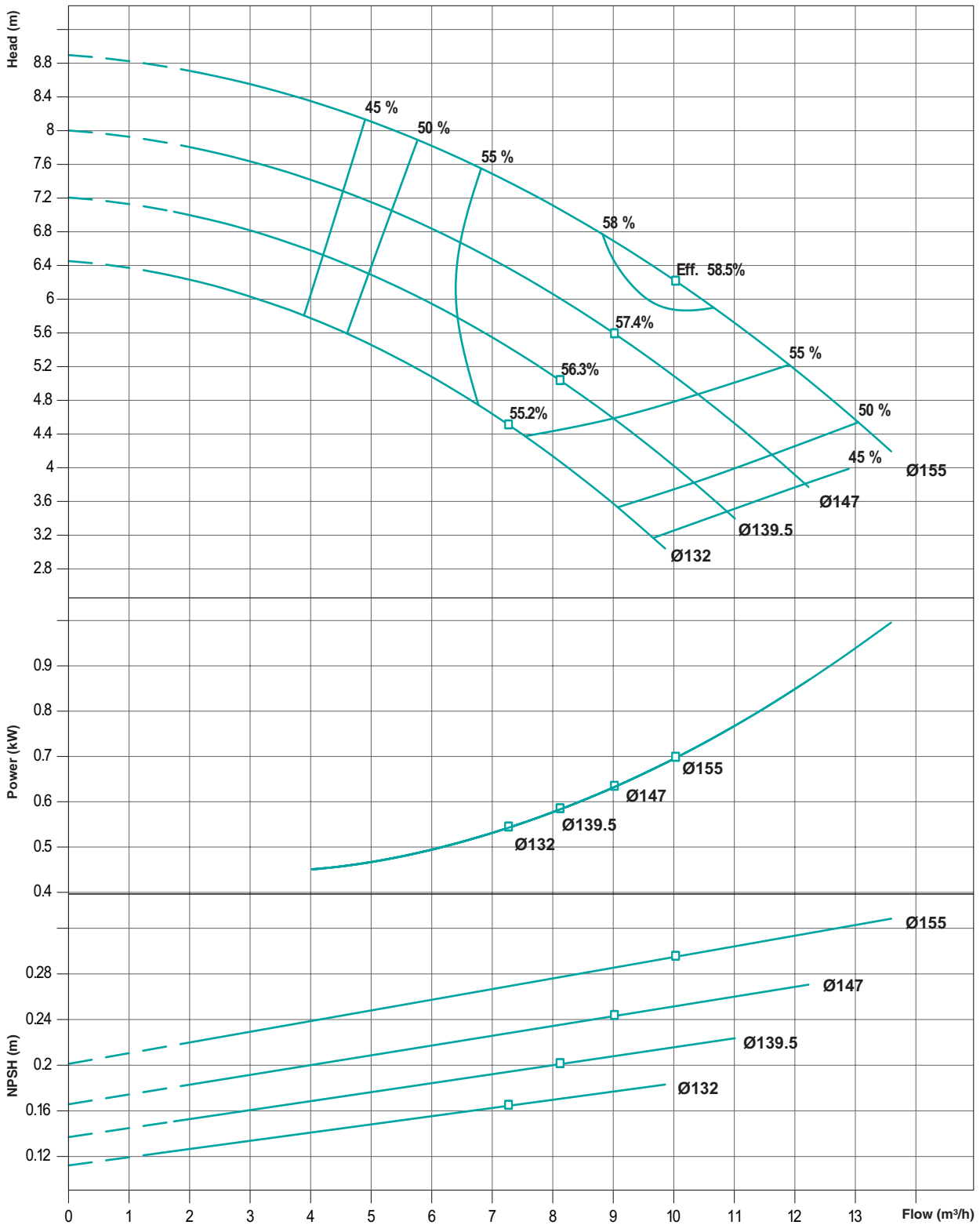

Performance curve tolerances are as per HI : 14.6 / ISO: 9906, Grade 2B

Note : Performance curve are as per specific gravity and viscosity of water.

PERFORMANCE CURVES

Model : **TEC-IL - 1.5 x 1.25 x 6**

Speed : **2900 rpm**

Suc x Del (in Inches) : **1.5 x 1.25**

Max. Impeller Ø : **155mm**

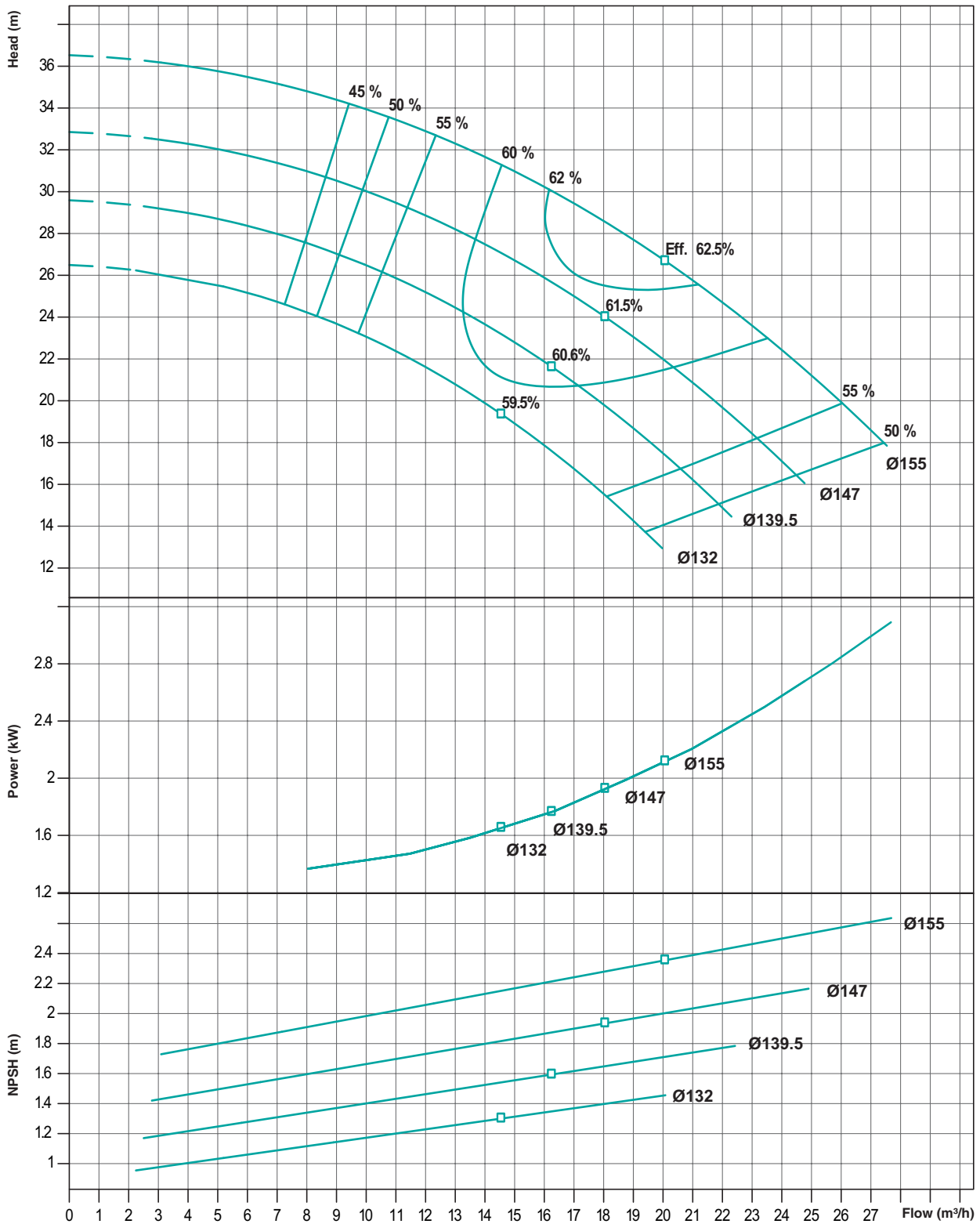

Performance curve tolerances are as per HI : 14.6 / ISO: 9906, Grade 2B

Note : Performance curve are as per specific gravity and viscosity of water.

PERFORMANCE CURVES

Model : **TEC-IL - 1 x 0.75 x 8**

Speed : **1450 rpm**

Suc x Del (in Inches) : **1 x 0.75**

Max. Impeller Ø : **203mm**

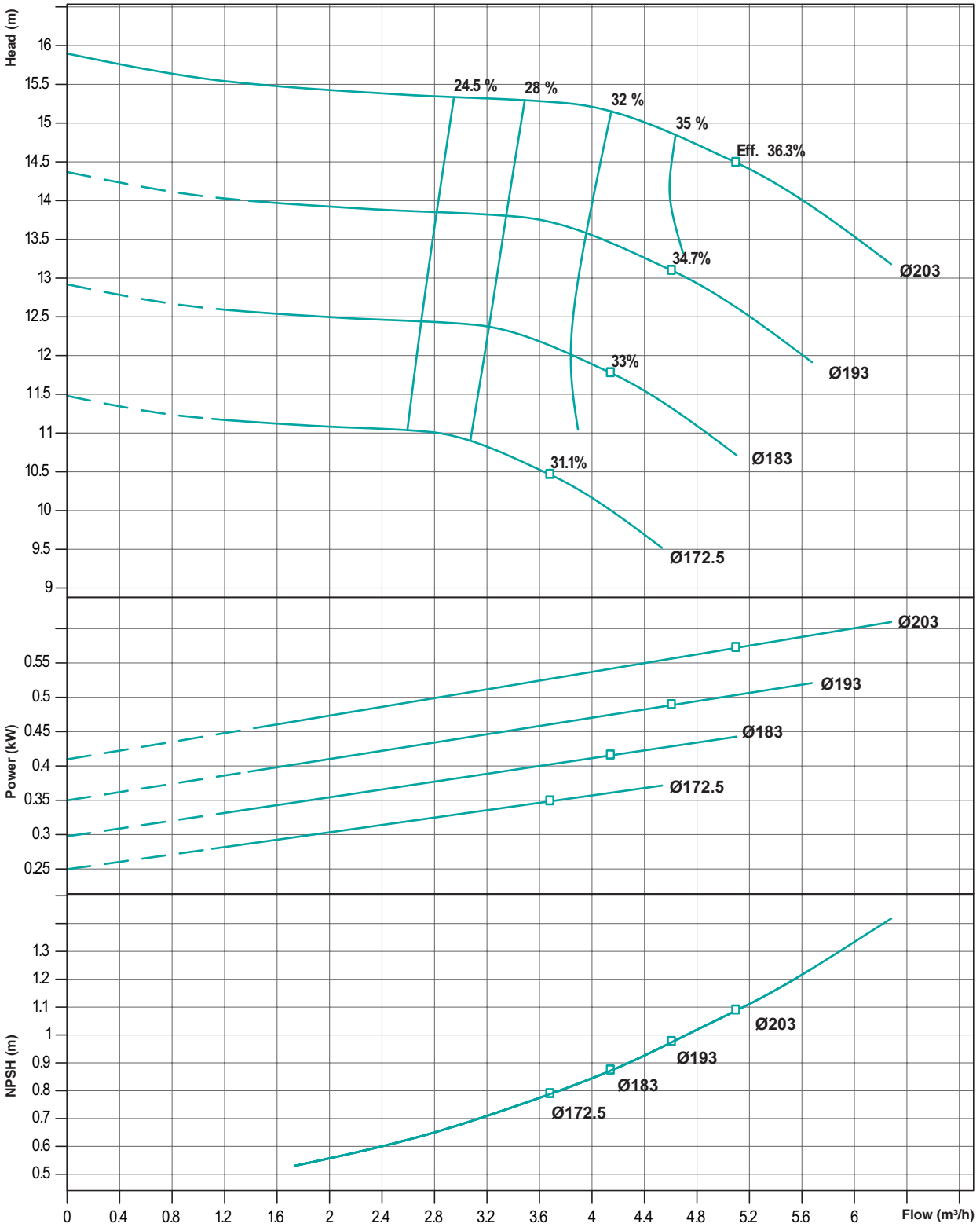

Performance curve tolerances are as per HI : 14.6 / ISO : 9906, Grade 2B

Note : Performance curve are as per specific gravity and viscosity of water.

PERFORMANCE CURVES

Model : **TEC-IL - 1 x 0.75 x 8**

Speed : **2900 rpm**

Suc x Del (in Inches) : **1 x 0.75**

Max. Impeller Ø : **203mm**

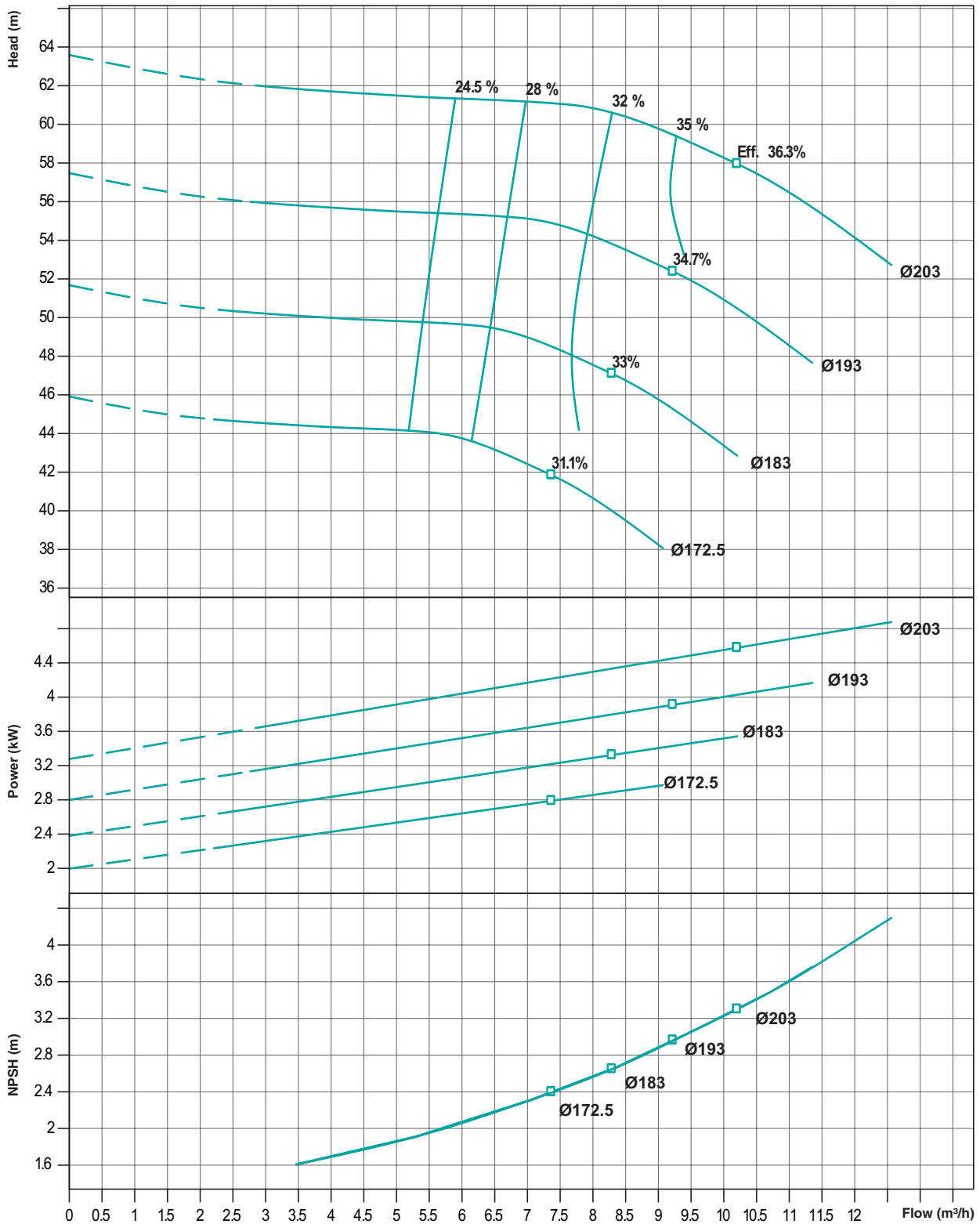

Performance curve tolerances are as per HI : 14.6 / ISO: 9906, Grade 2B

Note : Performance curve are as per specific gravity and viscosity of water.

PERFORMANCE CURVES

Model : **TEC-IL - 1.25 x 1 x 8**

Speed : **2900 rpm**

Suc x Del (in Inches) : **1.25 x 1**

Max. Impeller Ø : **205mm**

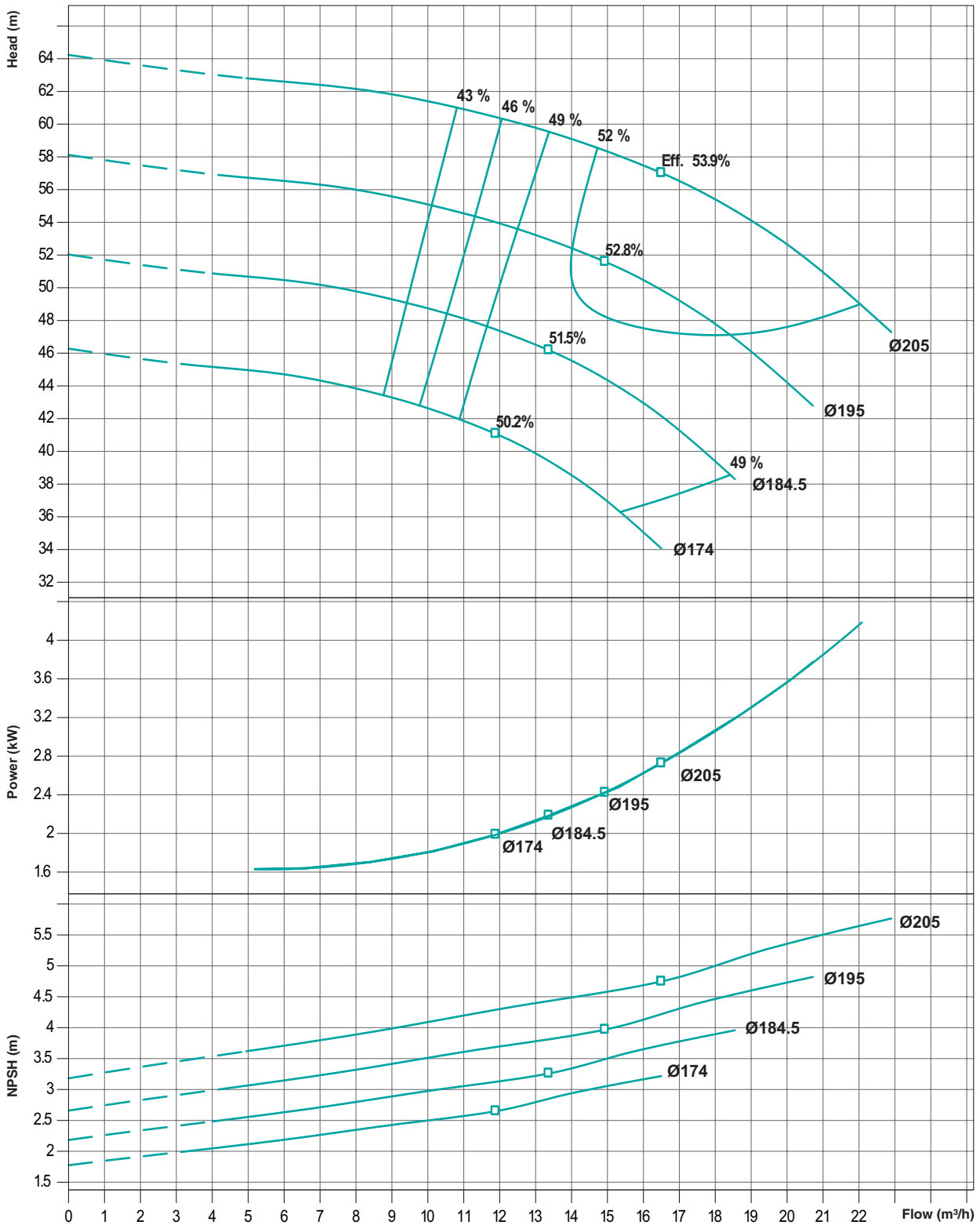

Performance curve tolerances are as per HI : 14.6 / ISO: 9906, Grade 2B

Note : Performance curve are as per specific gravity and viscosity of water.

PERFORMANCE CURVES

Model : **TEC-IL - 1.25 x 1 x 8**

Speed : **1450 rpm**

Suc x Del (in Inches) : **1.25 x 1**



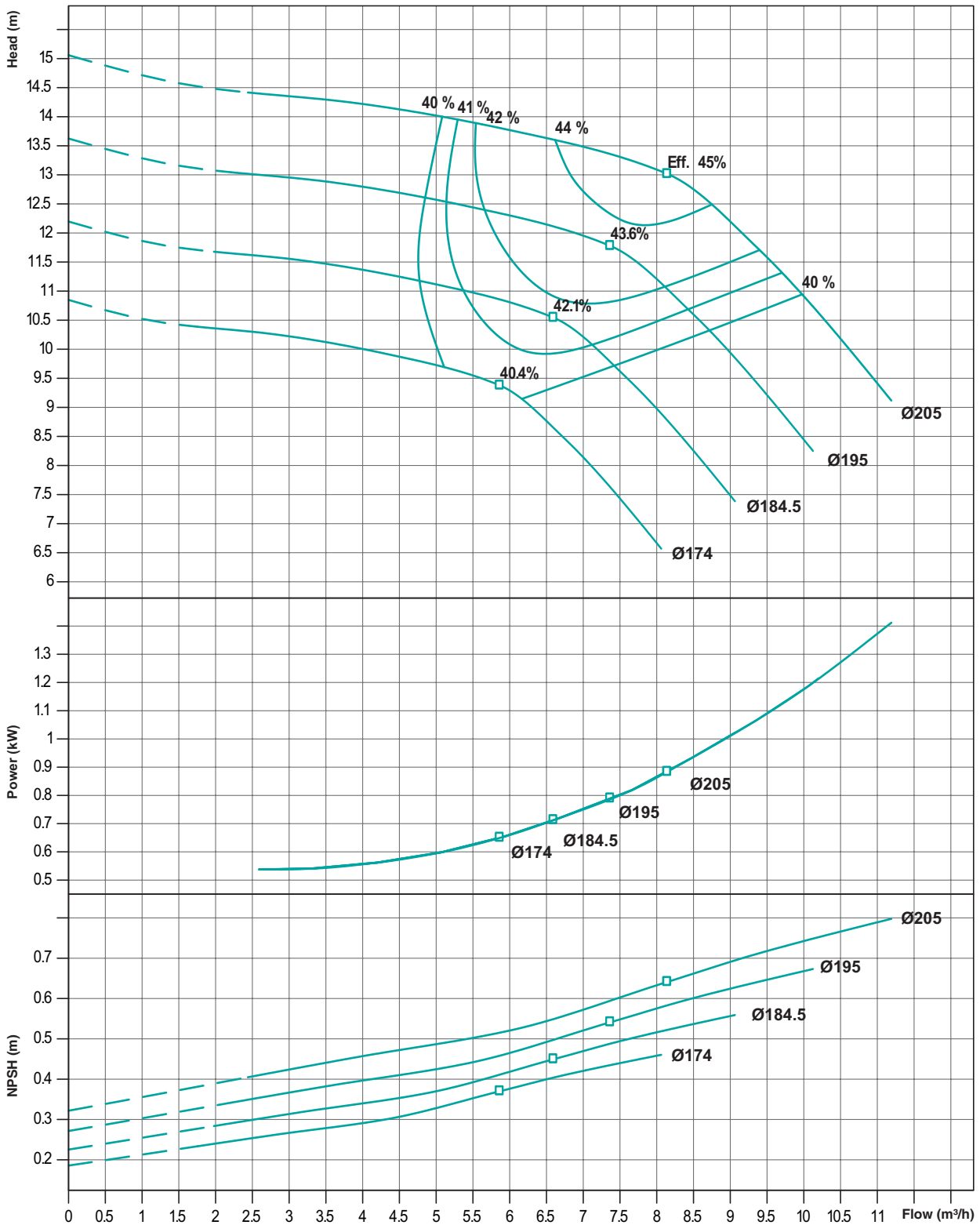













Max. Impeller Ø : **205mm**



Performance curve tolerances are as per HI : 14.6 / ISO: 9906, Grade 2B

Note : Performance curve are as per specific gravity and viscosity of water.

INTERCHANGEABILITY CHART

TEC - IL SERIES					
PUMP NAME	1 X 0.75 X 6	1.25 X 1 X 6	1.5 X 1.25 X 6	1 X 0.75 X 8	1.25 X 1 X 8
	25 X 20 X 150	32 X 25 X 150	40 X 32 X 150	25 X 20 X 200	32 X 25 X 200
CASING					
IMPELLER					
STUFFING BOX					
BEARING FRAME					
BEARING FRAME ASSEMBLY					

DETAILS OF STANDARD COMPONENTS

SHAFT AND BEARING DATA	FRAME
	0
SHAFT DIAMETER (mm)	
At Coupling	Ø 22.23
At 'NDE' Bearings	Ø 30
At 'DE' Bearings	Ø 30
Between bearings	Ø 51
Under Sleeve	Ø 27.97
Stuffing Box Details	
Shaft sleeve OD	Ø 35
Stuffing Box Bore Diameter	Ø 51
Stuffing Box Depth	57
SHAFT LENGTHS (mm)	
Impeller end of shaft to 'NDE' Bearing	156.5
Between bearings	85
'DE' Bearing. To Coupling end	95
BEARINGS	
'NDE'	6206
'DE'	6306
KEYWAY AT COUPLING (mm)	
Width	4.76
Depth	2.38
Length	40
SHAFT THREAD AT IMPELLER	M16X2 RH

BARE SHAFT PUMP - MOUNTING DIMENSIONS

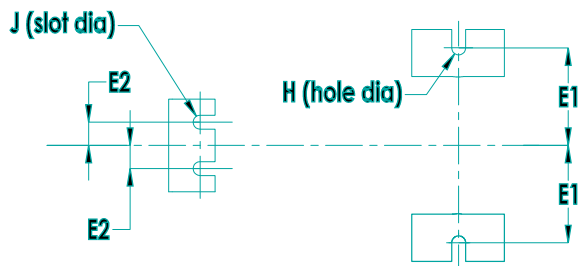
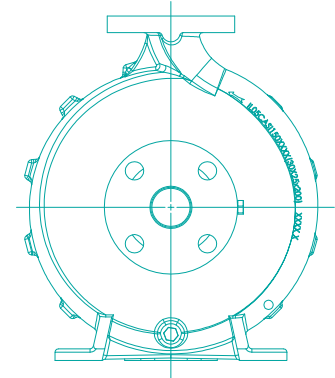
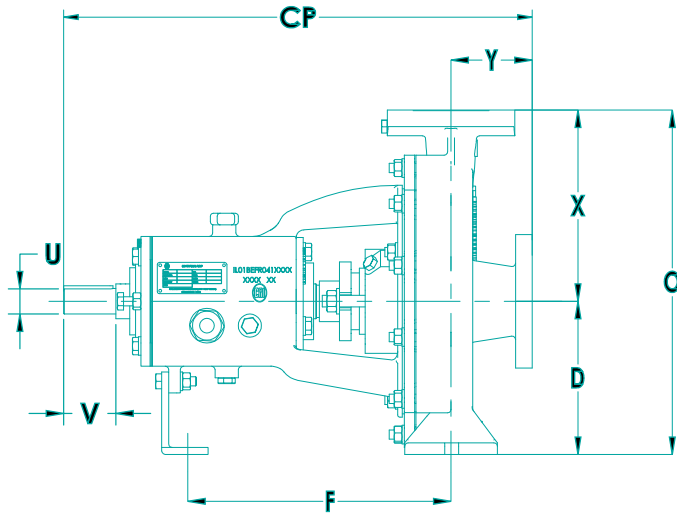

Pump Series	Pump Size - Suc x Del / Imp Ø (inch)	Mounting Dimensions (mm)												
		CP	D	E1	E2	F	X	Y	O	V	U (DIA)	H	J	M
TEC-IL	1 x 0.75 x 6	404	132	84	20	223	140	70	272	45	22	12	12	112
TEC-IL	1.25 x 1 x 6	404	132	84	20	223	140	70	272	45	22	12	12	112
TEC-IL	1.5 x 1.25 x 6	404	132	84	20	223	140	70	272	45	22	12	12	112
TEC-IL	1 x 0.75 x 8	404	132	84	20	223	165	70	297	45	22	12	12	112
TEC-IL	1.25 x 1 x 8	404	132	84	20	223	165	70	297	45	22	12	12	112

* Non Standard Models.

Note : All Dimensions are in mm, Unless Otherwise Specified

OVERALL RANGE & PERFORMANCE DETAILS

Pump performance curve details at 1450 rpm

Sl. No.	Pump Size - Suction x Discharge / Impeller Sizes (inch) (mm)	Suction Nozzle Dia. (mm)	Discharge Nozzle (mm)	Max. Power (kW)	Speed (rpm)	Max. Flow Rate (m ³ /hr)	Max. Head (m)	Maximum Suspended Solid Size (mm)	Pump Weight (Kg)
1	1 x 0.75 x 6 (25 x 20 x 150)	25	20	0.35	1450	6.6	8.4	4.5	22.5
2	1.25 x 1 x 6 (32 x 25 x 150)	32	25	0.30	1450	9.8	9.2	6.5	23
3	1.5 x 1 x 6 (40 x 32 x 15)	40	32	0.32	1450	13.6	8.9	8	24
4	1 x 0.75 x 8 (25 x 20 x 200)	25	20	0.60	1450	6.3	16	6	28
5	1.25 x 1 x 8 (32 x 25 x 200)	32	25	0.80	1450	11.2	15.06	9	29.5

* Non Standard Models.

Pump performance curve details at 2900 rpm

Sl. No.	Pump Size - Suction x Discharge / Impeller Sizes (inch) (mm)	Suction Nozzle Dia. (mm)	Discharge Nozzle (mm)	Max. Power (kW)	Speed (rpm)	Max. Flow Rate (m ³ /hr)	Max. Head (m)	Maximum Suspended Solid Size (mm)	Pump Weight (Kg)
1	1 x 0.75 x 6 (25 x 20 x 150)	25	20	1.6	2900	12.2	36	4.5	22.5
2	1.25 x 1 x 6 (32 x 25 x 150)	32	25	2.47	2900	19.7	36.8	6.5	23
3	1.5 x 1 x 6 (40 x 32 x 15)	40	32	2.6	2900	27.5	36.5	8	24
4	1 x 0.75 x 8 (25 x 20 x 200)	25	20	4.8	2900	12.5	63	6	28
5	1.25 x 1 x 8 (32 x 25 x 200)	32	25	5.77	2900	22.8	64.2	9	30

* Non Standard Models.



T H E P O W E R B E H I N D T H E F O R C E

Naargo Industries Private Limited, one of the leading manufacturers of latest state of art, large range of pumps and motors, is managed by veterans who are in the pump industry for almost half a century. The products are employed in various applications like irrigation, domestic, civil construction, de-watering etc; The Company has a strong distribution network in India for sales & service and a strong global presence.

Quality is the key factor in Naargo's products. The expansive infrastructure and environment accredited with ISO 9001 quality certification, latest engineering softwares, high-tech machinery, futuristic pumping technology and high caliber workforce facilitate the production of flawless and efficient products on par with international standards under the brand name of "Tormac". The well equipped R & D wing stays alive to the changing global trends and comes out with viable solutions for innovative product development and upgradation.

The Products currently available include Stainless Steel Submersible Pumps (SS 304, SS 316 & SS 904L), Submersible Motors (CI, SS 304, SS 316 & SS 904L - HT on optional), Starters & Control Panels, Centrifugal Monoblock Pumps, End Suction Pumps, Close Coupled Pumps, Horizontal Split Case Pumps, Horizontal & Vertical Multistage Pumps, Inline Booster Systems, Sewage, Drainage & Dewatering Pumps, Induction Motors, Submersible Cables, Riser Pipes and Column Pipes.

The power, performance and endurance of the products backed by the uncompromising teamwork and value systems will certainly propel the company's growth towards new horizons in the pump industry.

Naargo Industries Private Limited,

REG. OFFICE : No. 8/116, Ground Floor, Athipalayam Road, Chinnavedampatti,
Coimbatore North - 641049, Tamil Nadu, India. Tel : +91 978 6522622,
E-mail : tormac@tormacpumps.com, Web : www.tormacpumps.com