



AXIALLY SPLIT CASE DOUBLE SUCTION PUMPS THSC SERIES - 60HZ



INDEX

AXIALLY SPLIT CASE DOUBLE SUCTION PUMPS THSC SERIES - 60Hz

Model Identification Code & Materials of Construction	4
General Pump Selection & Operation Instructions	5
Description, Key Features, Applications & Technical Specifications	6
Exploded View	7-9
Performance Curves	10-56
Interchangeability Chart	57-58
Bare Shaft Pump - Mounting Dimensions	59-60

GENERAL DATA

Model Classification) SPLIT CASE PUMPS

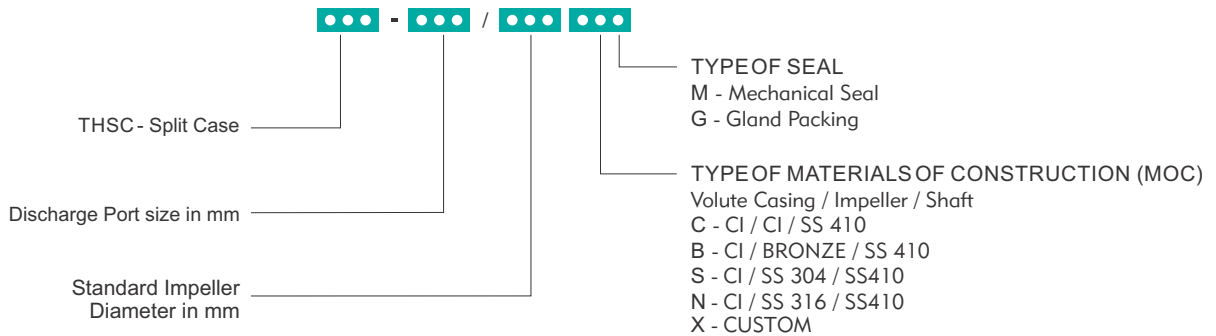

Example : **THSC-80/285 CG**

MATERIAL OF CONSTRUCTION

TYPE - CCKK

Parts Name	Material (Code)	SAE/AISI	DIN	EUROPEAN
Casing	Cast Iron (C)	ASTM A48 class 40B	(0.6025) GG25	EN-GJL-250
Impeller	Cast Iron (C)	ASTM A48 class 30B	(0.6020) GG20	EN-GJL-220
Stuffing Box	Cast Iron (C)	ASTM A48 class 40B	(0.6025) GG25	EN-GJL-250
Wear Ring	Cast Iron (C)	ASTM A48 class 30B	(0.6020) GG20	EN-GJL-220
Bearing Housing	Cast Iron (C)	ASTM A48 class 30B	(0.6020) GG20	EN-GJL-220
Shaft	SS 410 (K)	ASTM A276 AISI 410	1.4006	X12Cr13
Shaft Sleeve	SS 410 (K)	ASTM A276 AISI 410	1.4006	X12Cr13

TYPE - CBKK

Parts Name	Material (Code)	SAE/AISI	DIN	EUROPEAN
Casing	Cast Iron (C)	ASTM A48 class 40B	(0.6025) GG25	EN-GJL-250
Impeller	Bronze LTB2 (B)	ASTM B584 - C90500	DIN 1705 Rg 5	CuSn5Zn5Pb5C
Stuffing Box	Cast Iron (C)	ASTM A48 class 40B	(0.6025) GG25	EN-GJL-250
Wear Ring	Bronze LTB4 (B)	ASTM B505 C93800	DIN 1716-1981	G-CuPb15Sn
Bearing Housing	Cast Iron (C)	ASTM A48 class 30B	(0.6020) GG20	EN-GJL-220
Shaft	SS 410 (K)	ASTM A276 AISI 410	1.4006	X12Cr13
Shaft Sleeve	SS 410 (K)	ASTM A276 AISI 410	1.4006	X12Cr13

TYPE - CWKK

Parts Name	Material (Code)	SAE/AISI	DIN	EUROPEAN
Casing	Cast Iron (C)	ASTM A48 class 40B	(0.6025) GG25	EN-GJL-250
Impeller	WCB (W)	ASTM A216 WCB	1.0619	GP240GH
Stuffing Box	Cast Iron (C)	ASTM A48 class 40B	(0.6025) GG25	EN-GJL-250
Wear Ring	Bronze LTB4 (B)	ASTM B505 C93800	DIN 1716-1981	G-CuPb15Sn
Bearing Housing	Cast Iron (C)	ASTM A48 class 30B	(0.6020) GG20	EN-GJL-220
Shaft	SS 410 (K)	ASTM A276 AISI 410	1.4006	X12Cr13
Shaft Sleeve	SS 410 (K)	ASTM A276 AISI 410	1.4006	X12Cr13

TYPE - CSKK

Parts Name	Material (Code)	SAE/AISI	DIN	EUROPEAN
Casing	Cast Iron (C)	ASTM A48 class 40B	(0.6025) GG25	EN-GJL-250
Impeller	SS 304 (S)	ASTM A743/A351 CF8	1.4308	X5CrNi18-9
Stuffing Box	Cast Iron (C)	ASTM A48 class 40B	(0.6025) GG25	EN-GJL-250
Wear Ring	Bronze LTB4 (B)	ASTM B505 C93800	DIN 1716-1981	G-CuPb15Sn
Bearing Housing	Cast Iron (C)	ASTM A48 class 30B	(0.6020) GG20	EN-GJL-220
Shaft	SS 410 (K)	ASTM A276 AISI 410	1.4006	X12Cr13
Shaft Sleeve	SS 410 (K)	ASTM A276 AISI 410	1.4006	X12Cr13

TYPE - CNKK

Parts Name	Material (Code)	SAE/AISI	DIN	EUROPEAN
Casing	Cast Iron (C)	ASTM A48 class 40B	(0.6025) GG25	EN-GJL-250
Impeller	SS 316 (N)	ASTM A743 / A351 CF8M	1.4408	X6CrNiMo18-10
Stuffing Box	Cast Iron (C)	ASTM A48 class 40B	(0.6025) GG25	EN-GJL-250
Wear Ring	Bronze LTB4 (B)	ASTM B505 C93800	DIN 1716-1981	G-CuPb15Sn
Bearing Housing	Cast Iron (C)	ASTM A48 class 30B	(0.6020) GG20	EN-GJL-220
Shaft	SS 410 (K)	ASTM A276 AISI 410	1.4006	X12Cr13
Shaft Sleeve	SS 410 (K)	ASTM A276 AISI 410	1.4006	X12Cr13

Optional Materials : Duplex, Super Duplex and other materials are available on request.

The Company reserves the right to modify the technical specifications and illustrations without prior notice.

GENERAL PUMP SELECTION & OPERATION INSTRUCTIONS

1. All performance curves are based on water (specific gravity = 1.0; low viscosity). Corrections must be applied for fluids with different properties.
2. Select a motor or engine with sufficient power margin above the pump duty point. This prevents overloading under normal and transient operating conditions.
3. Always calculate NPSHA (Net Positive Suction Head Available) carefully, especially when pumping hot or cold liquids with negative or positive suction. Account for vapor pressure effects.
4. Ensure $NPSHA \geq NPSHR + 0.5m$ to avoid cavitation during both negative and positive suction conditions.
5. For high-viscosity fluids, apply viscosity correction factors to head, flow and efficiency.
6. Choose pumps to operate within 70% to 120% of the Best Efficiency Point (BEP) against flow. Operating within this range ensures better efficiency, reliability, and reduced wear.
7. Select pump materials based on fluid properties:
 - i. Chemical compatibility
 - ii. Operating temperature
 - iii. Abrasiveness or corrosiveness
8. Use suction and discharge piping at least one nominal size larger than the pump nozzle to reduce friction losses and turbulence.
9. Delivery Side:
 - i. Install a Non-Return Valve (NRV) to prevent backflow.
 - ii. Install a gate or globe valve to control flow during start-up/shutdown.
10. Start-Up and Shut-Down Procedure:
 - i. Keep the delivery valve closed when starting or stopping the pump.
 - ii. For mixed flow pumps and pumps with a rising power curve toward shut-off, the pump must be started and stopped with the delivery valve in the open position, or as per the manufacturer's specific recommendations.
11. All pump performance curve tolerances conform to HI : 14.6 / ISO : 9906 Grade 2B standards.

AXIALLY SPLIT CASE DOUBLE SUCTION PUMPS > THSC SERIES

Construction

The horizontal split case single-stage double suction centrifugal pumps are engineered to provide a high flow rate at a specified operating head. These pumps feature a double suction impeller with a between-bearing design, which ensures hydraulic balance, effectively eliminating axial thrust. The pump casing is designed with an axial split, where the suction and discharge flanges are positioned opposite each other, which significantly simplifies maintenance tasks. The inline suction and discharge nozzles are integrated into the lower half casing, facilitating easier maintenance access. This construction allows the upper casing and rotary components to be removed without disturbing the motor or connected pipework, enhancing operational convenience and reducing downtime.



OPERATING DATA

Head Range	15 - 122m
Flow Range	50 - 4150m ³ /h
Speed	960 / 1450 / 2900 rpm
Impeller Type	Double Suction Impeller
Outlet Size	3" - 18"
Power Range	7.5 - 900kW
Maximum Liquid Temperature	-10°C to 90°C
Shaft Seal	Standard : Gland Packing
	Optional : Mechanical seal
Bearing Lubrication	Grease, Oil
Flange Standard	DIN
Maximum working Pressure	10 - 16 bar

Applications

- Raw water intake and supply
- Public water supply
- Cooling water circulation
- Cooling tower
- Fire Fighting System
- HVAC systems
- Irrigation
- Water Treatment plants
- Flood control
- Refinery
- Steel and power plants

Features

- Top Pull out design
- Split case design allows easy access to pump internal parts for maintenance
- Rigid and balanced design
- Low NPSH double suction impeller
- Designed for maximum wear life, minimum down time and reduced life time costs
- Common housing for gland and mechanical seal

EXPLODED VIEW

Gland Packing Construction

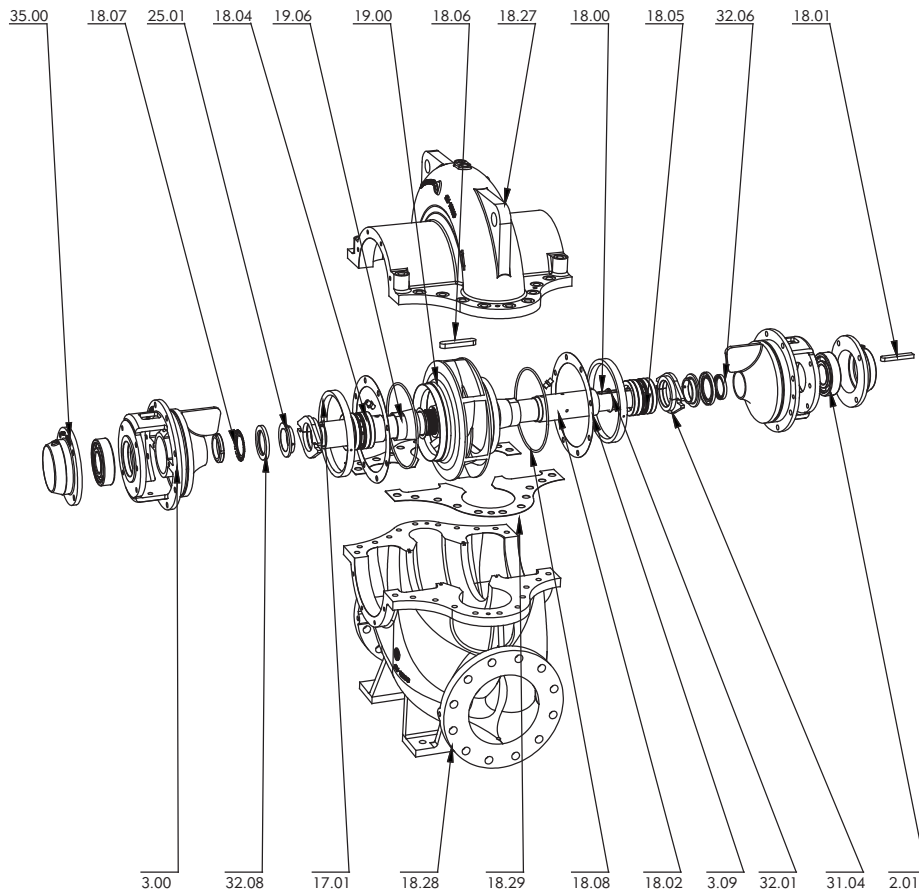

Cross Sectional View

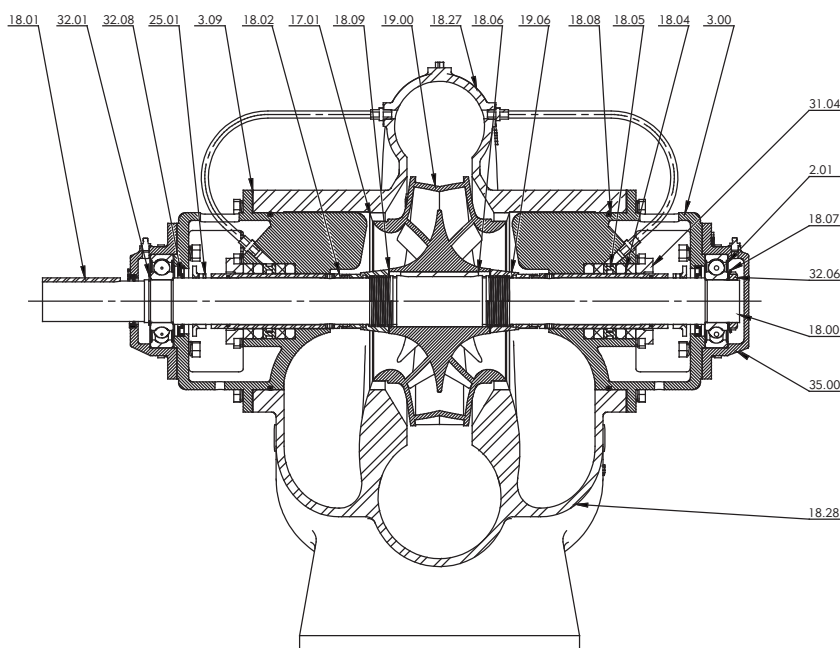

PART NO	PART NAME
18.27	Top Half casing
18.28	Bottom Half Casing
19.00	Impeller
3.00	Stuffing Box
17.01	Wear Ring
2.01	Deep Groove Ball Bearing
32.08	Oil Seal
18.00	Shaft
18.01	Parallel Key
18.07	Bearing Lock Washer
31.04	Gland Packing
3.09	Gasket - Stuffing Box
18.06	Parallel Key
18.02	Shaft Sleeve
18.04	Packing SQ
18.05	Ring Lantern
18.09	Gasket - Sleeve
35.00	Bearing Housing
32.01	Circlip
32.06	Lock Nut
18.08	O-Ring
19.06	Impeller Nut
25.01	Deflector
18.29	Gasket - Casing

EXPLODED VIEW

Mechanical Seal Construction (Cartridge Type)

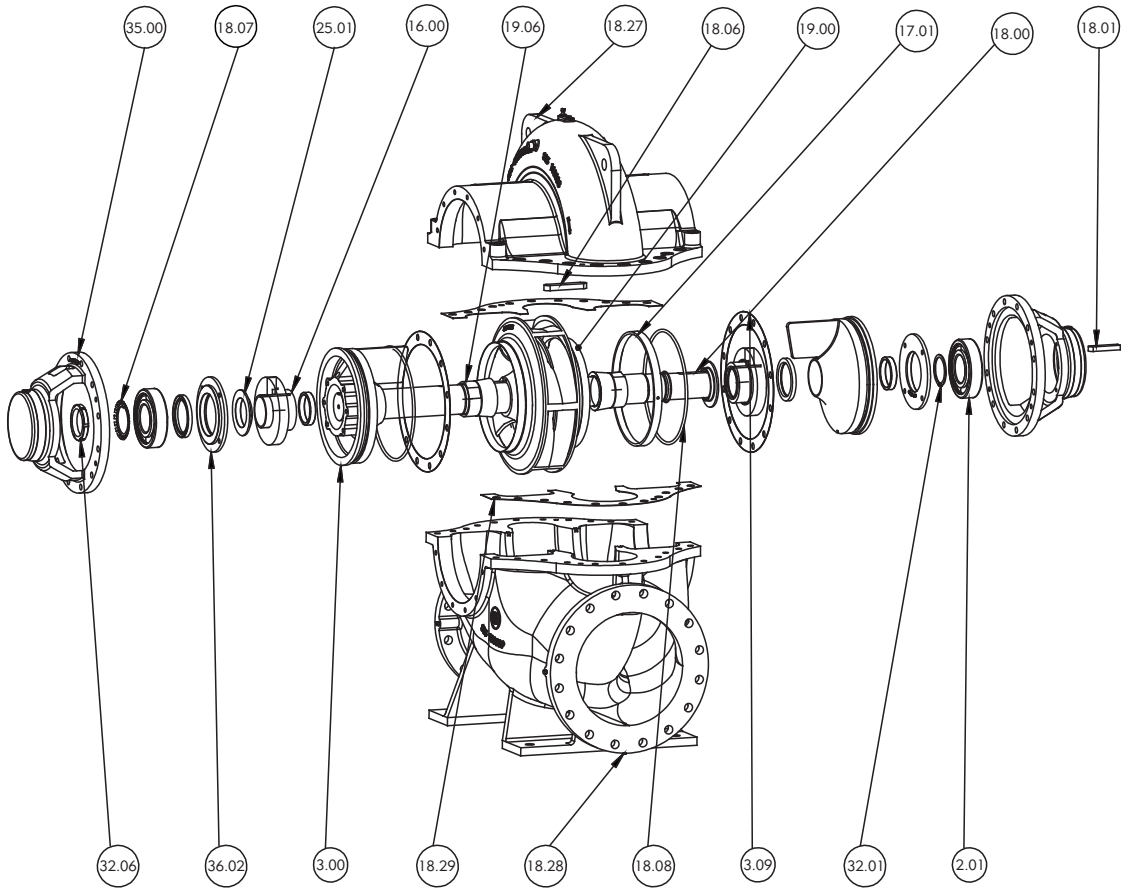

Cross Sectional View

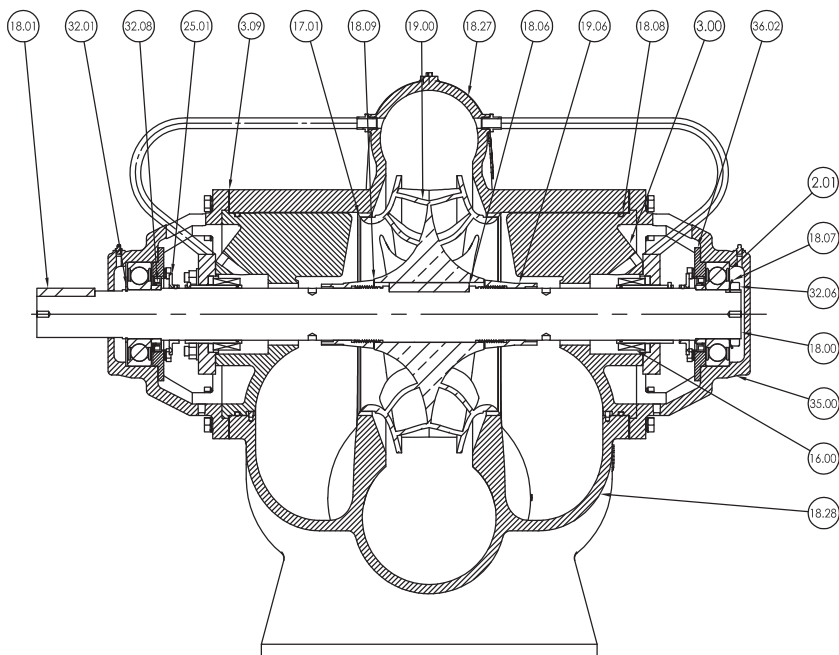

PART NO	PART NAME
18.27	Top Half casing
18.28	Bottom Half Casing
19.00	Impeller
3.00	Stuffing Box
17.01	Wear Ring
2.01	Deep Groove Ball Bearing
32.08	Oil Seal
18.00	Shaft
18.01	Parallel Key
18.07	Bearing Lock Washer
3.09	Gasket - Stuffing Box
18.06	Parallel Key
36.02	Bearing Cover
16.00	Mechanical seal with gland
18.09	Gasket - Sleeve
35.00	Bearing Housing
32.01	Circlip
32.06	Lock Nut
18.08	O-Ring
19.06	Impeller Nut
25.01	Deflector
18.29	Gasket - Casing

EXPLODED VIEW

Mechanical Seal Construction (Bellow Type)

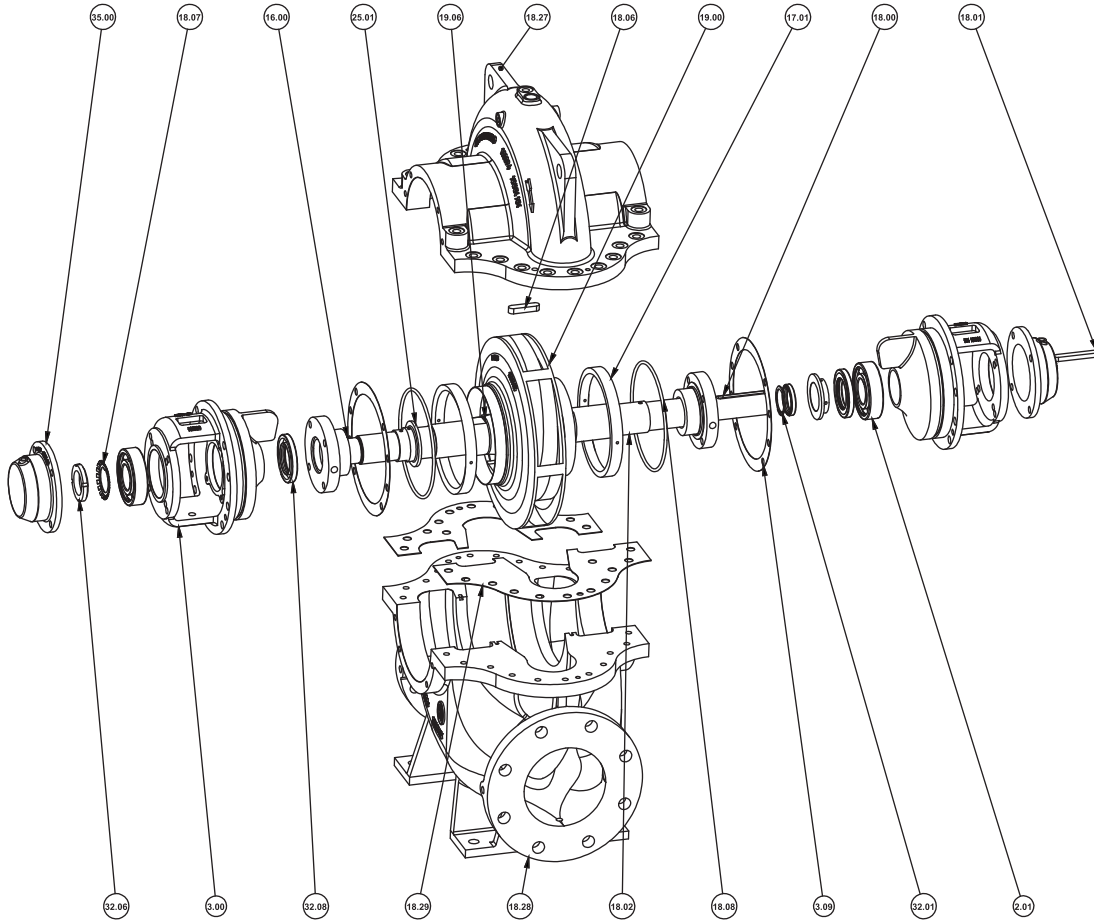

Cross Sectional View

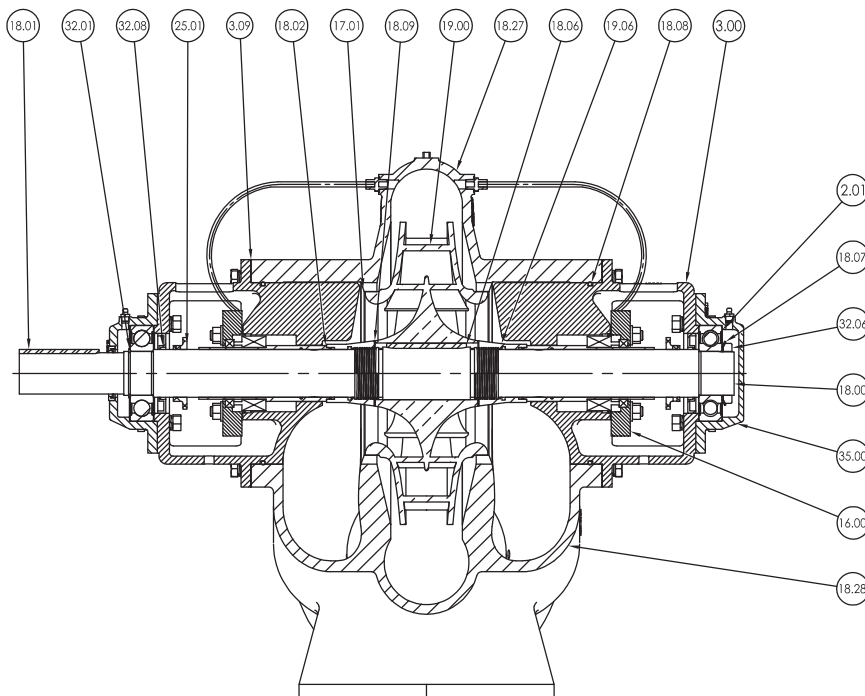

PART NO	PART NAME
18.27	Top Half casing
18.28	Bottom Half Casing
19.00	Impeller
3.00	Stuffing Box
17.01	Wear Ring
2.01	Deep Groove Ball Bearing
32.08	Oil Seal
18.00	Shaft
18.01	Parallel Key
18.07	Bearing Lock Washer
3.09	Gasket - Stuffing Box
18.06	Parallel Key
36.02	Bearing Cover
16.00	Mechanical seal with gland
18.09	Gasket - Sleeve
35.00	Bearing Housing
32.01	Circlip
32.06	Lock Nut
18.08	O-Ring
19.06	Impeller Nut
25.01	Deflector
18.29	Gasket - Casing

PERFORMANCE CURVES

Model : **THSC-80/285**

Speed : **1750 rpm**

Suc x Del (in mm) : **80 x 80**

Max. Impeller Ø : **285mm**

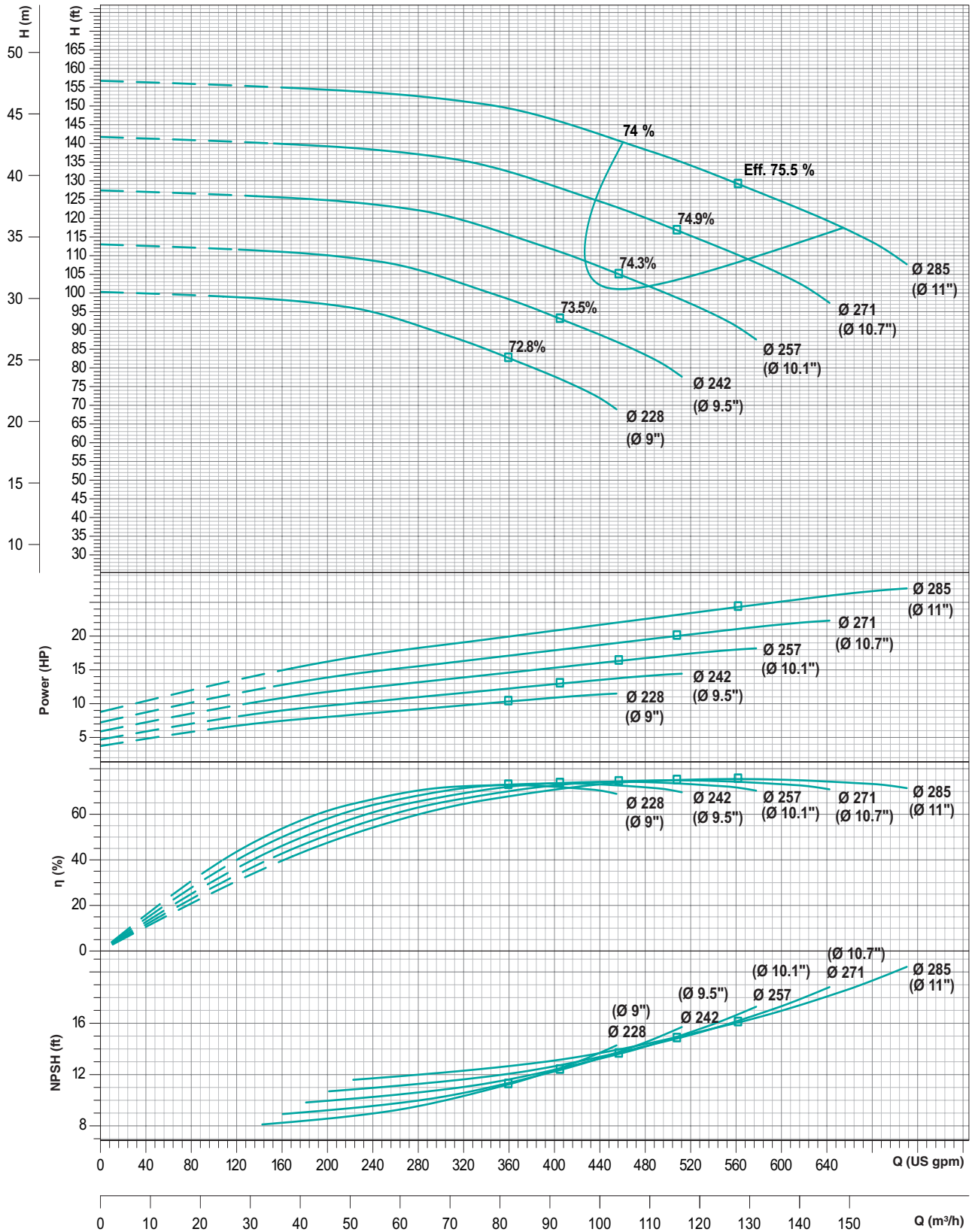

Performance curve tolerances are as per HI : 14.6 / ISO 9906, Grade 2B.
 Note : Performance curve are as per specific gravity and viscosity of water.

PERFORMANCE CURVES

Model : **THSC-100/300**

Speed : **1750 rpm**

Suc x Del (in mm) : **125 x 100**

Max. Impeller Ø : **300mm**

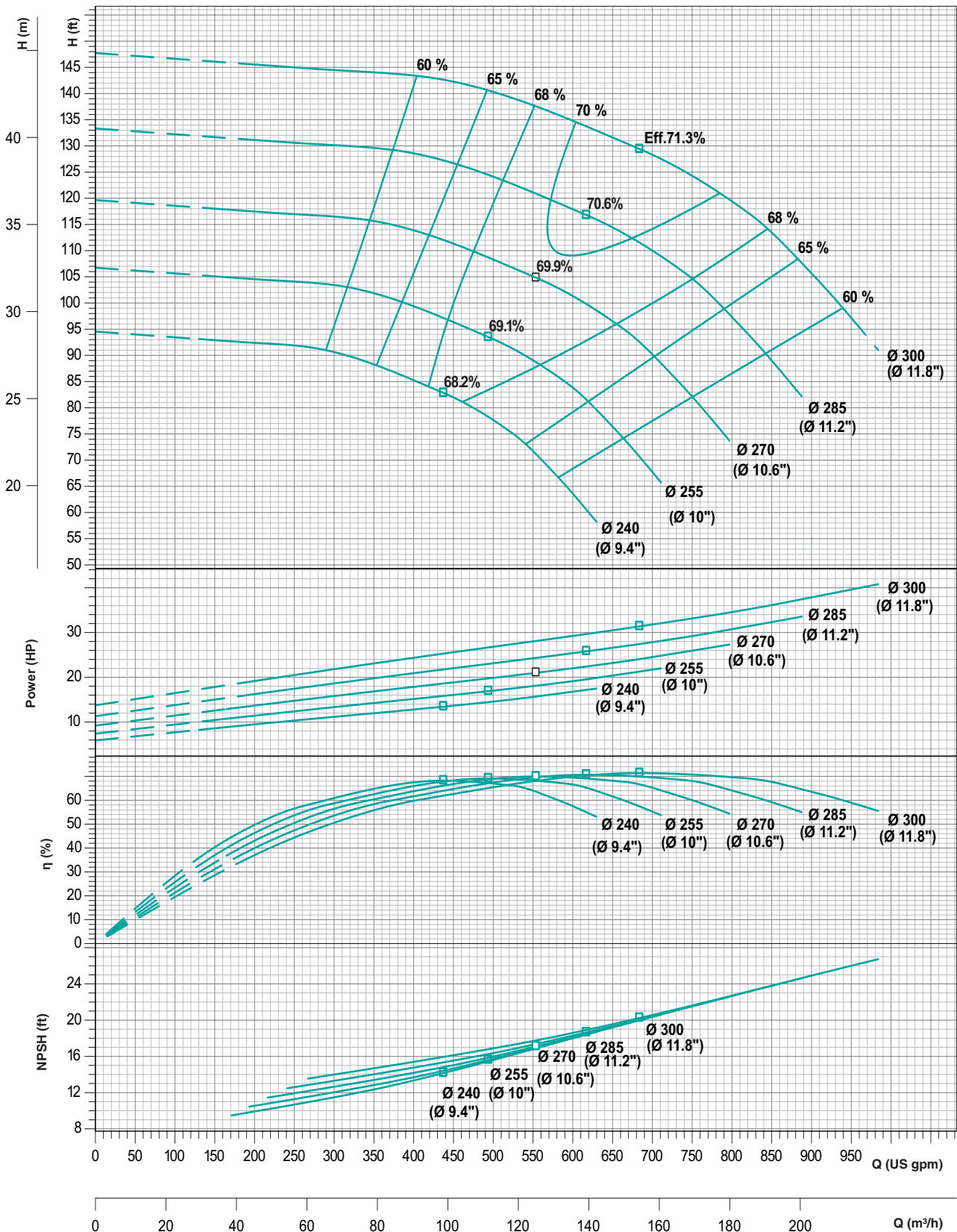

Performance curve tolerances are as per HI : 14.6 / ISO 9906, Grade 2B.
 Note : Performance curve are as per specific gravity and viscosity of water.

PERFORMANCE CURVES

Model : **THSC-100/305**

Speed : **1750 rpm**

Suc x Del (in mm) : **100 x 80**

Max. Impeller Ø : **300mm**

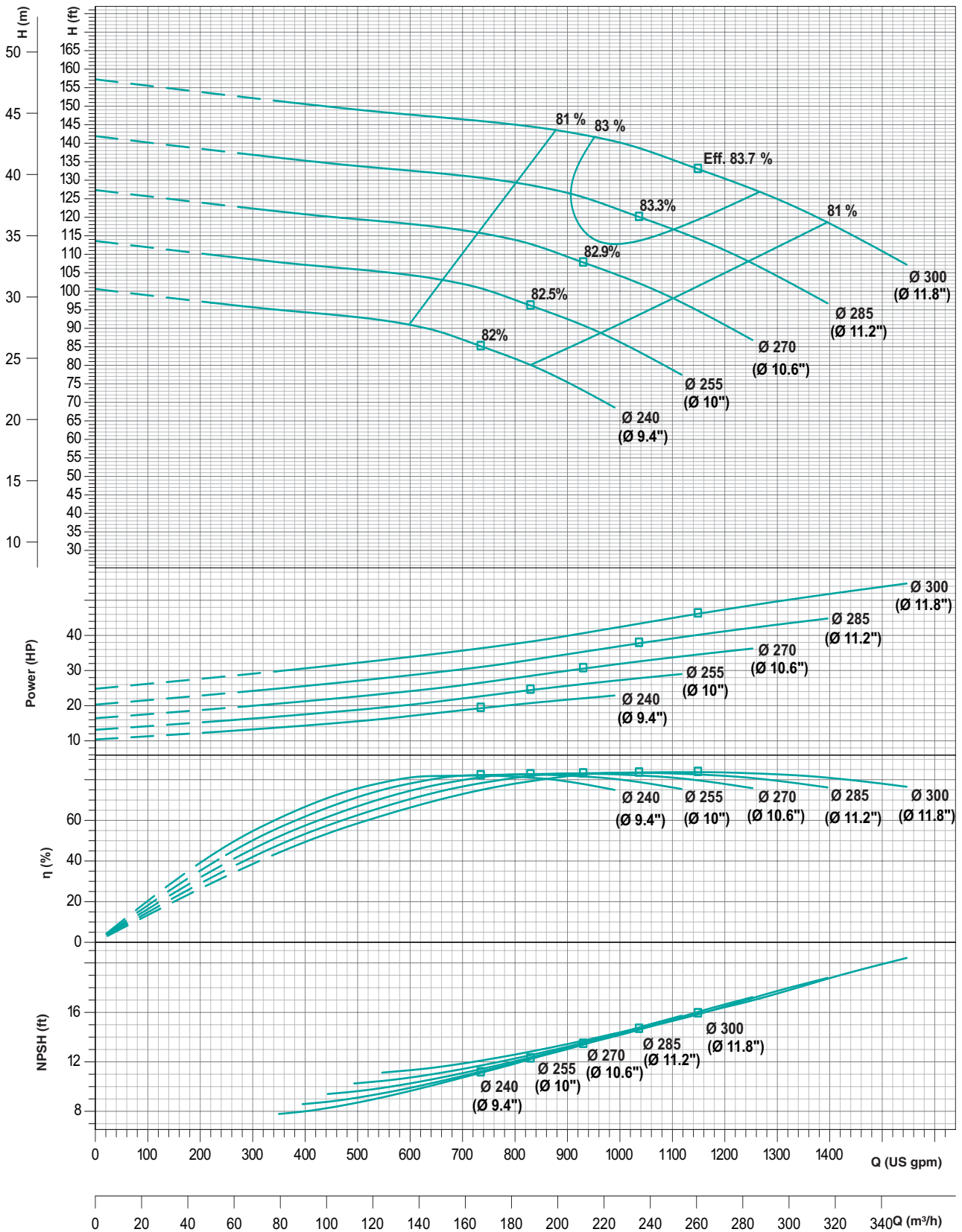

Performance curve tolerances are as per HI : 14.6 / ISO 9906, Grade 2B.

Note : Performance curve are as per specific gravity and viscosity of water.

PERFORMANCE CURVES

Model : **THSC-150/300**

Speed : **1750 rpm**

Suc x Del (in mm) : **150 x 150**

Max. Impeller Ø : **300mm**

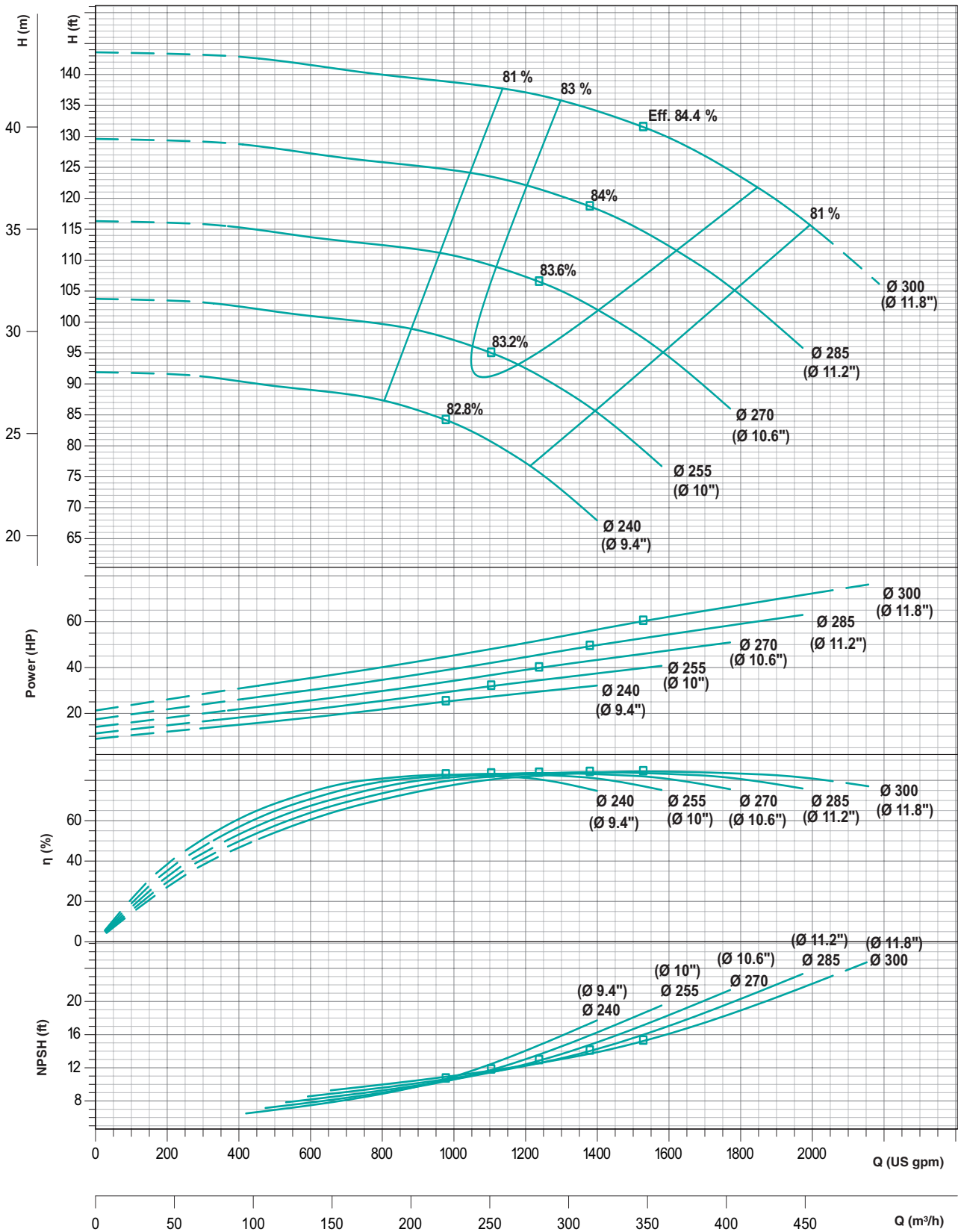

Performance curve tolerances are as per HI : 14.6 / ISO 9906, Grade 2B.
 Note : Performance curve are as per specific gravity and viscosity of water.

PERFORMANCE CURVES

Model : **THSC-150/305**

Speed : **1750 rpm**

Suc x Del (in mm) : **200 x 150**

Max. Impeller Ø : **300mm**

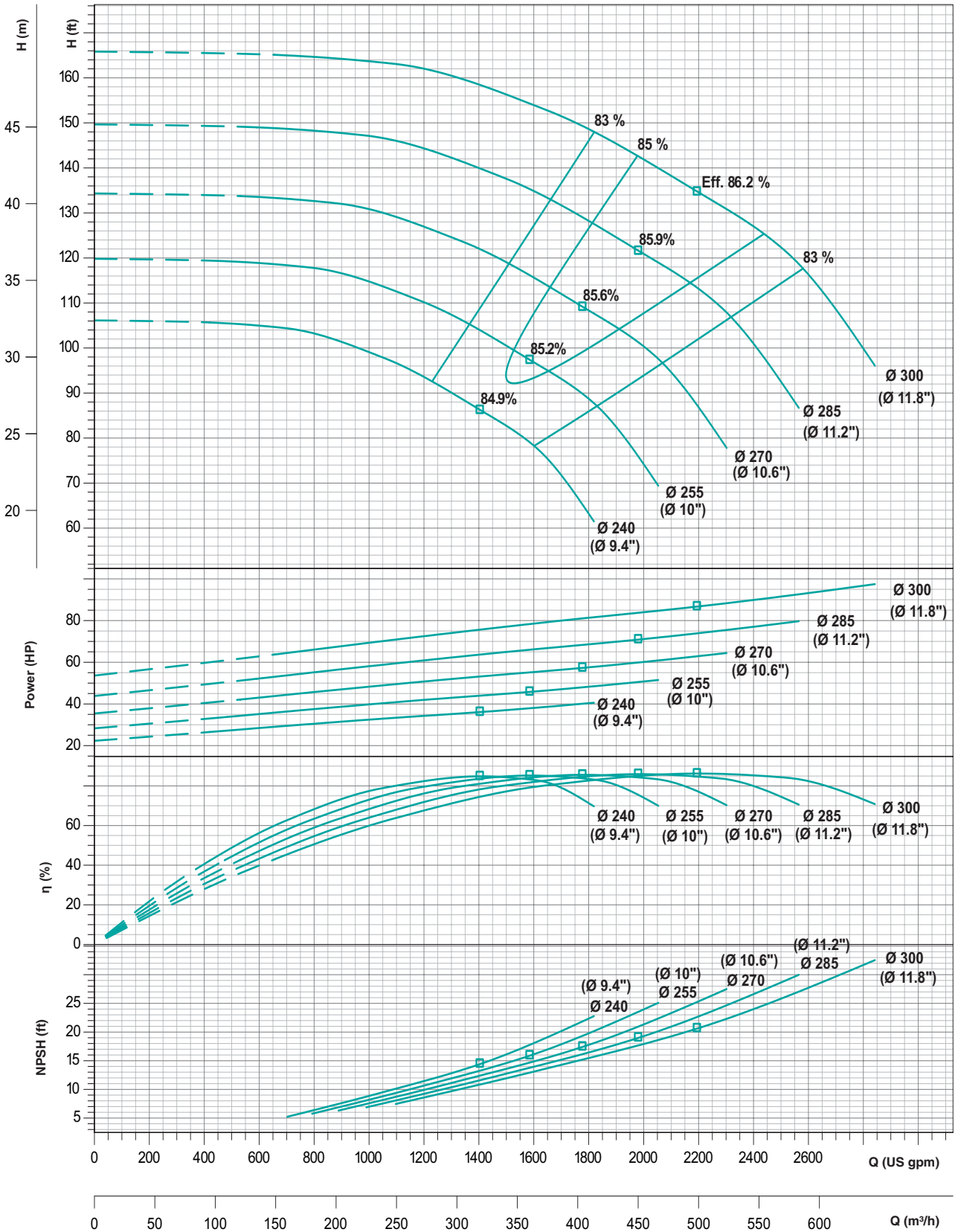

Performance curve tolerances are as per HI : 14.6 / ISO 9906, Grade 2B.

Note : Performance curve are as per specific gravity and viscosity of water.

PERFORMANCE CURVES

Model : **THSC-200/320**

Speed : **1750 rpm**

Suc x Del (in mm) : **200 x 200**

Max. Impeller Ø : **320mm**

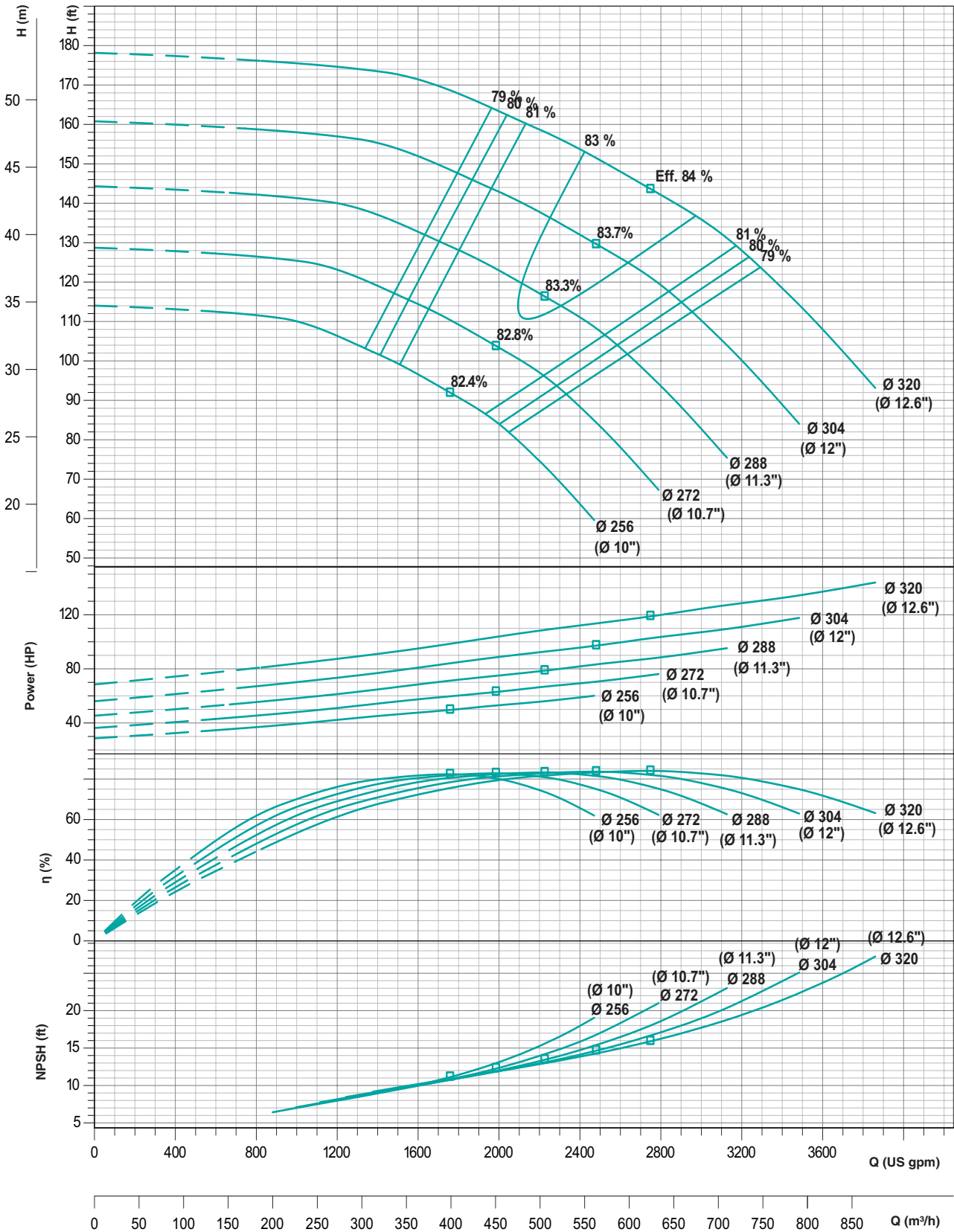

Performance curve tolerances are as per HI : 14.6 / ISO 9906, Grade 2B.
 Note : Performance curve are as per specific gravity and viscosity of water.

PERFORMANCE CURVES

Model : **THSC-250/330**

Speed : **1750 rpm**

Suc x Del (in mm) : **250 x 250**

Max. Impeller Ø : **330mm**

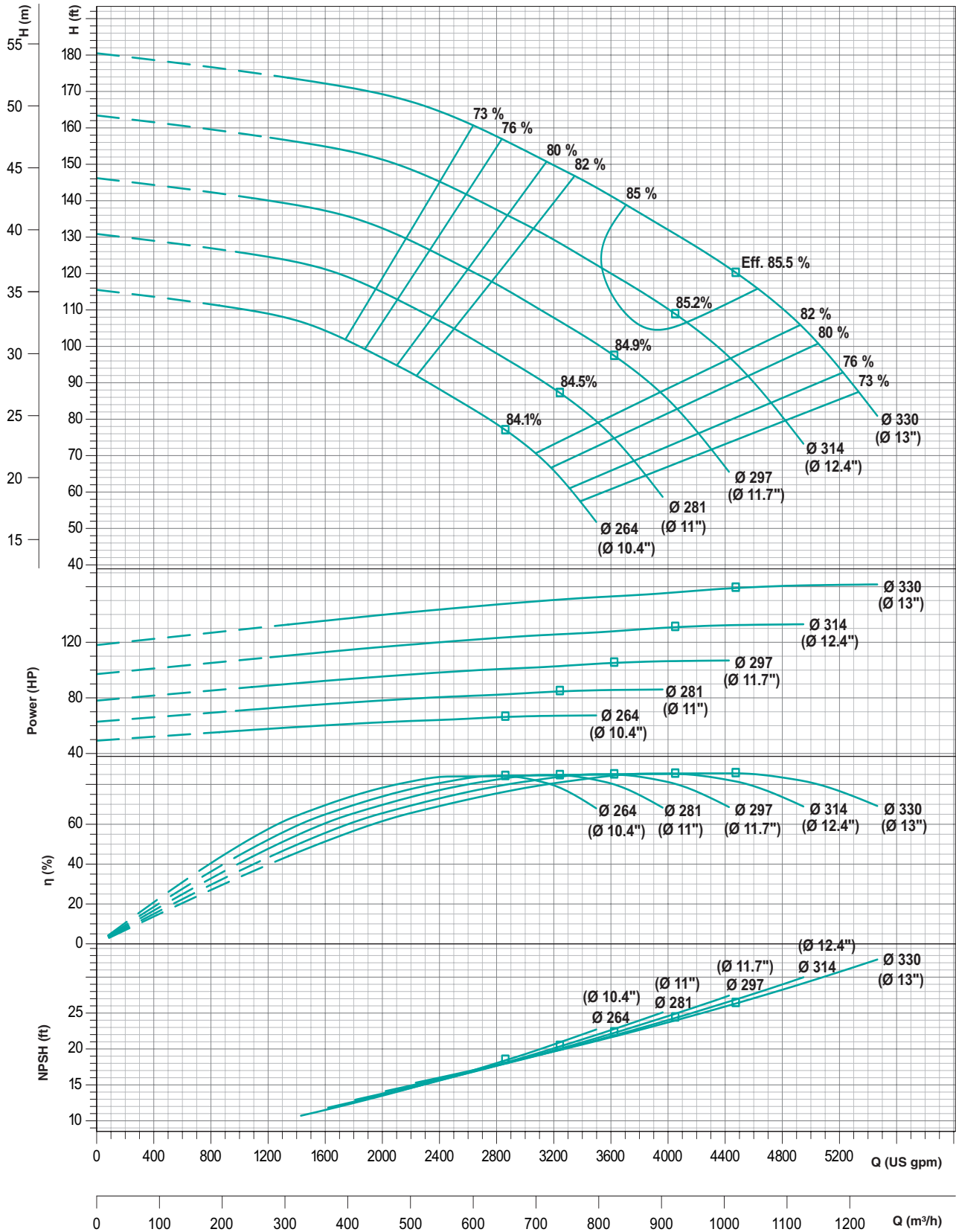

Performance curve tolerances are as per HI : 14.6 / ISO 9906, Grade 2B.

Note : Performance curve are as per specific gravity and viscosity of water.

PERFORMANCE CURVES

Model : **THSC-100/320**

Speed : **1750 rpm**

Suc x Del (in mm) : **100 x 100**

Max. Impeller Ø : **320mm**

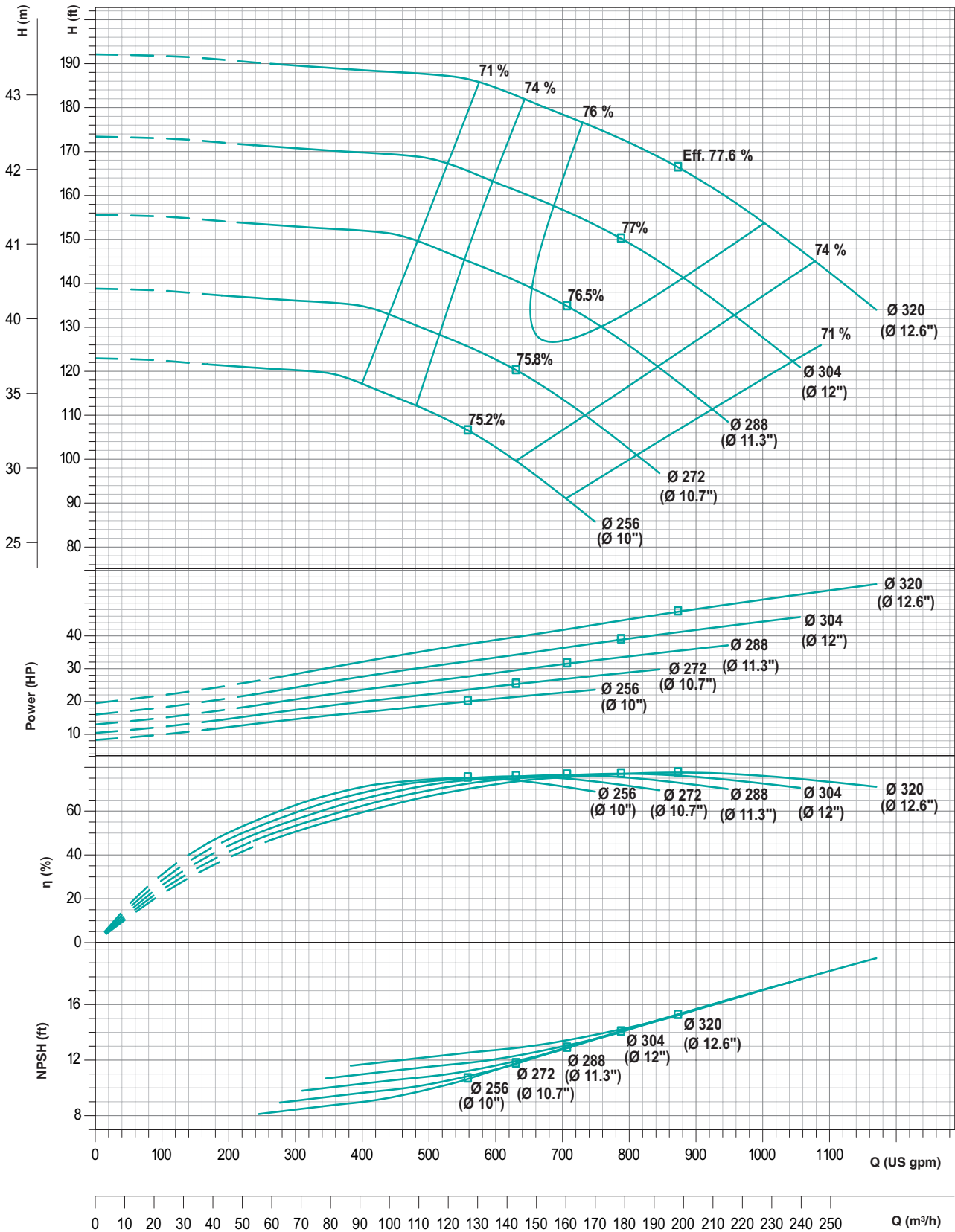

Performance curve tolerances are as per HI : 14.6 / ISO 9906, Grade 2B.
 Note : Performance curve are as per specific gravity and viscosity of water.

PERFORMANCE CURVES

Model : **THSC-125/360**

Speed : **1750 rpm**

Suc x Del (in mm) : **125 x 125**

Max. Impeller Ø : **360mm**

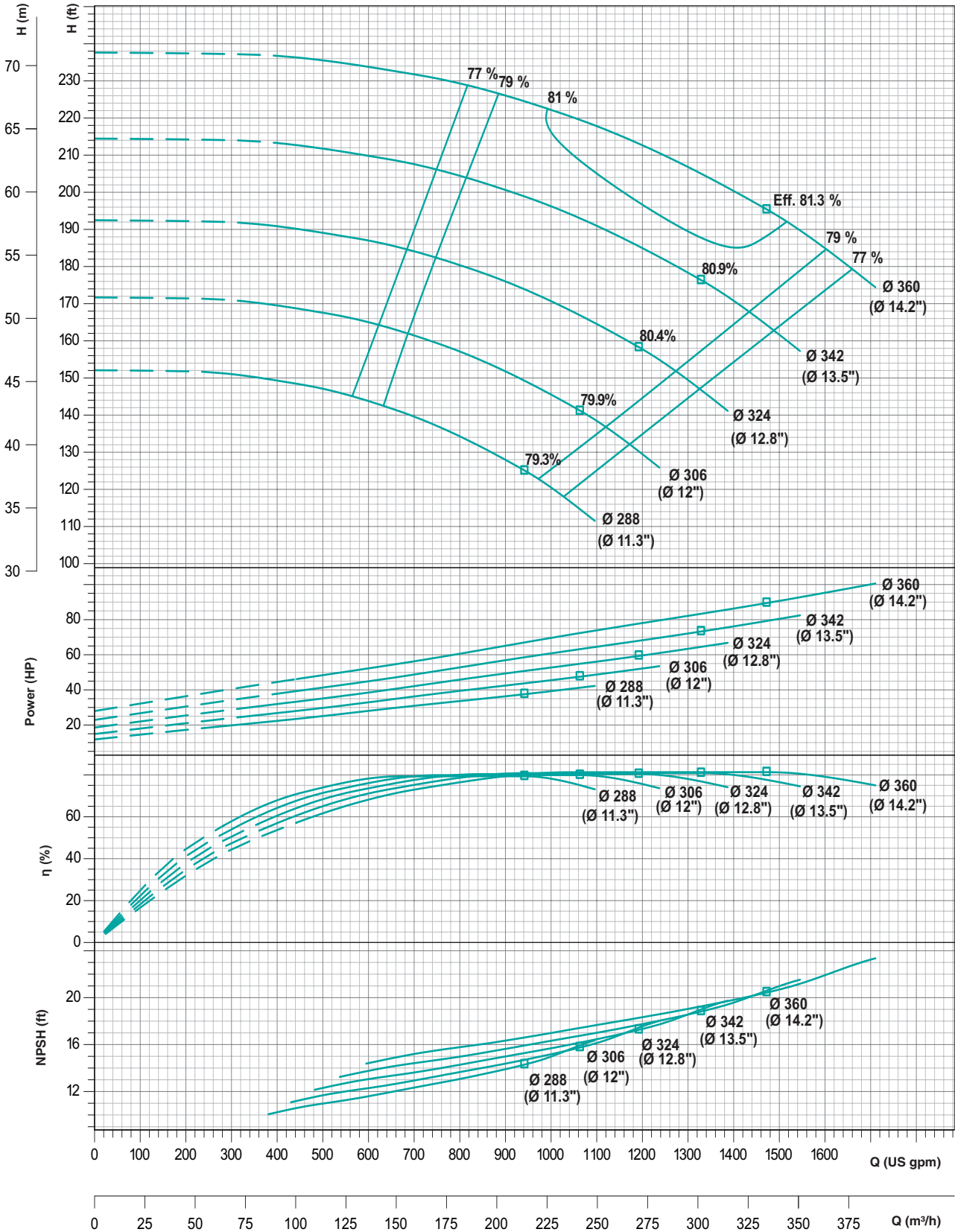

Performance curve tolerances are as per HI : 14.6 / ISO 9906, Grade 2B.
 Note : Performance curve are as per specific gravity and viscosity of water.

PERFORMANCE CURVES

Model : **THSC-125/400**

Speed : **1750 rpm**

Suc x Del (in mm) : **150 x 125**

Max. Impeller Ø : **405mm**

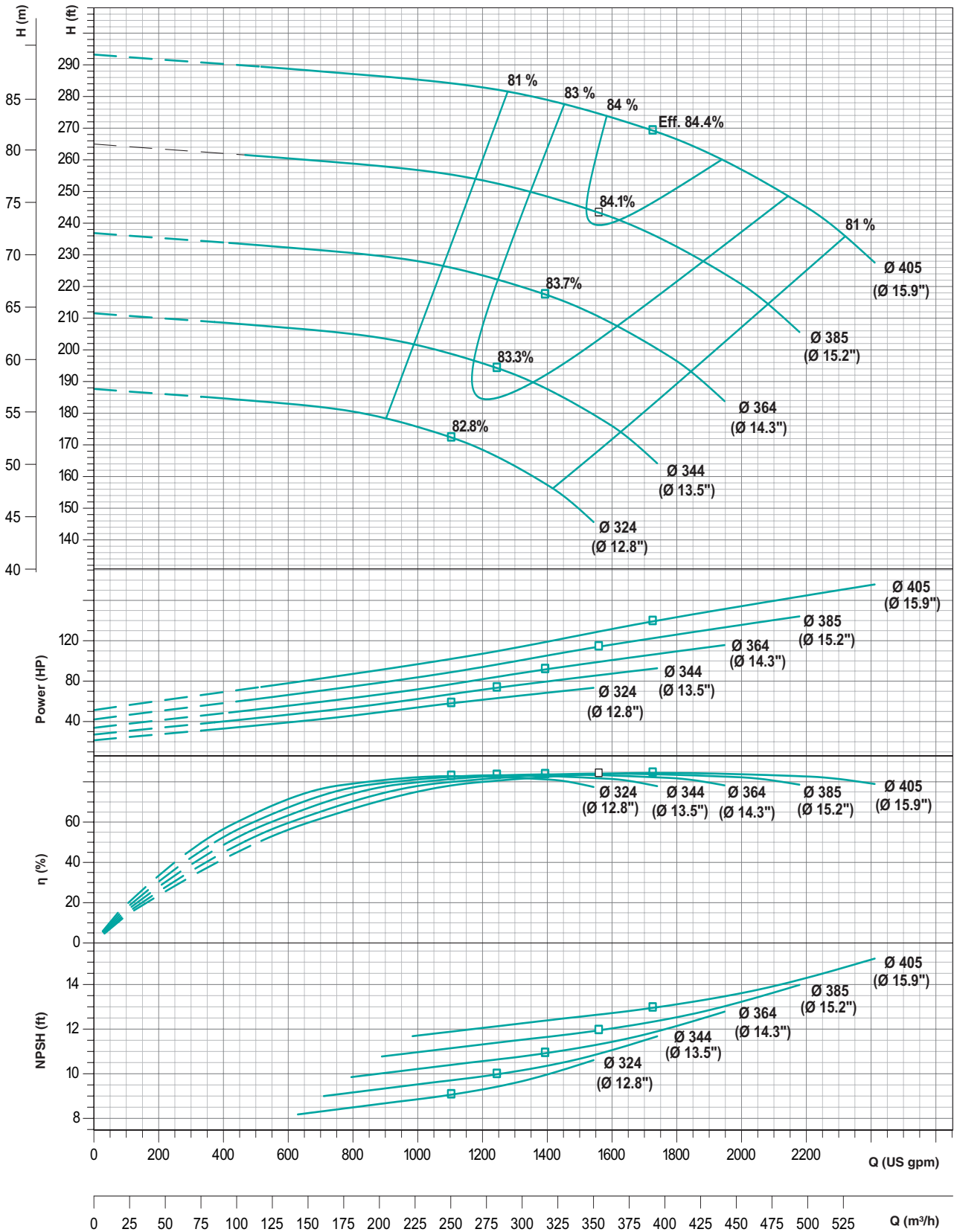

Performance curve tolerances are as per HI : 14.6 / ISO 9906, Grade 2B.
 Note : Performance curve are as per specific gravity and viscosity of water.

PERFORMANCE CURVES

Model : **THSC-150/450**

Speed : **1750 rpm**

Suc x Del (in mm) : **200 x 150**

Max. Impeller Ø : **455mm**

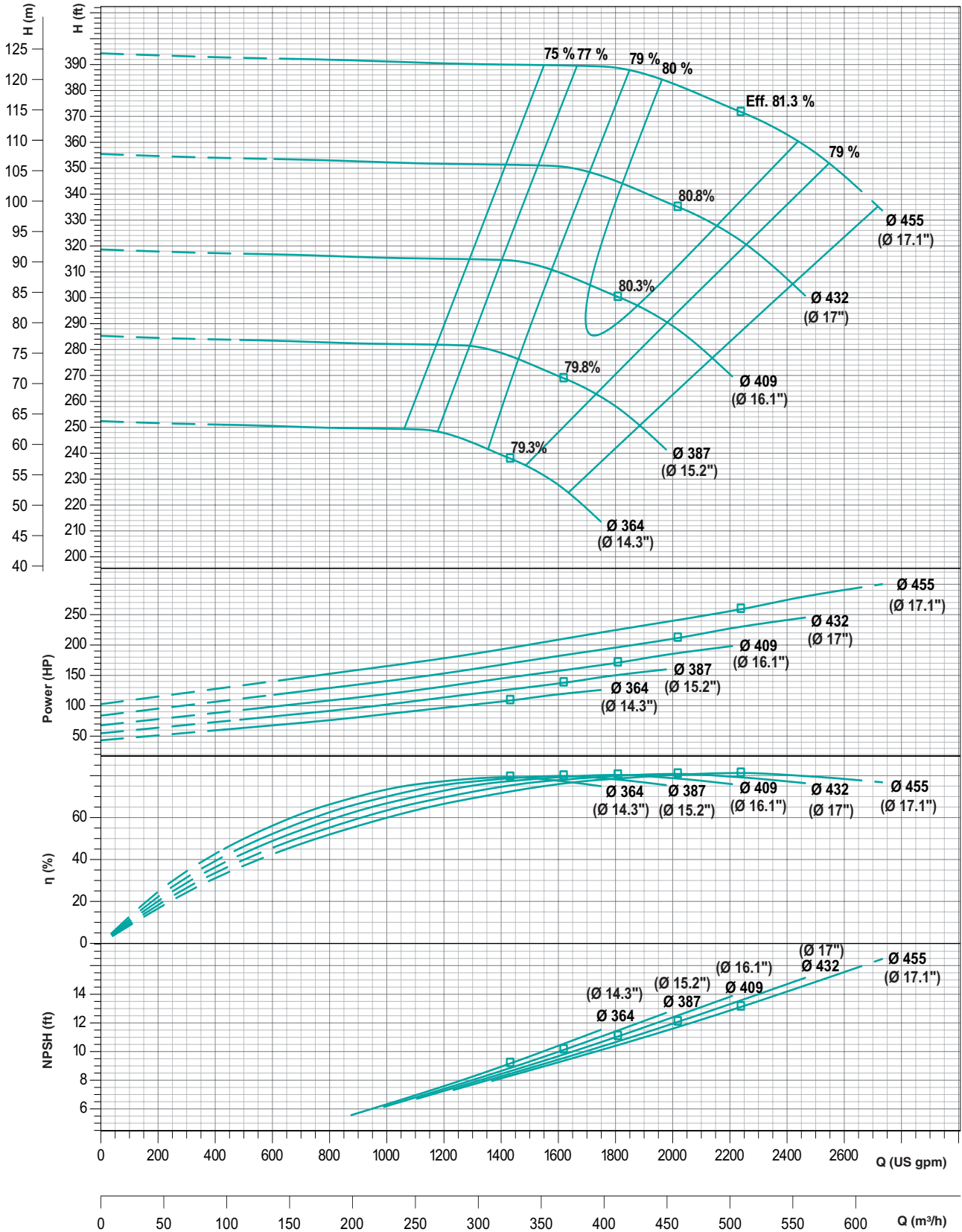

Performance curve tolerances are as per HI : 14.6 / ISO 9906, Grade 2B.
 Note : Performance curve are as per specific gravity and viscosity of water.

PERFORMANCE CURVES

Model : **THSC-200/510**

Speed : **1750 rpm**

Suc x Del (in mm) : **200 x 200**

Max. Impeller Ø : **510mm**

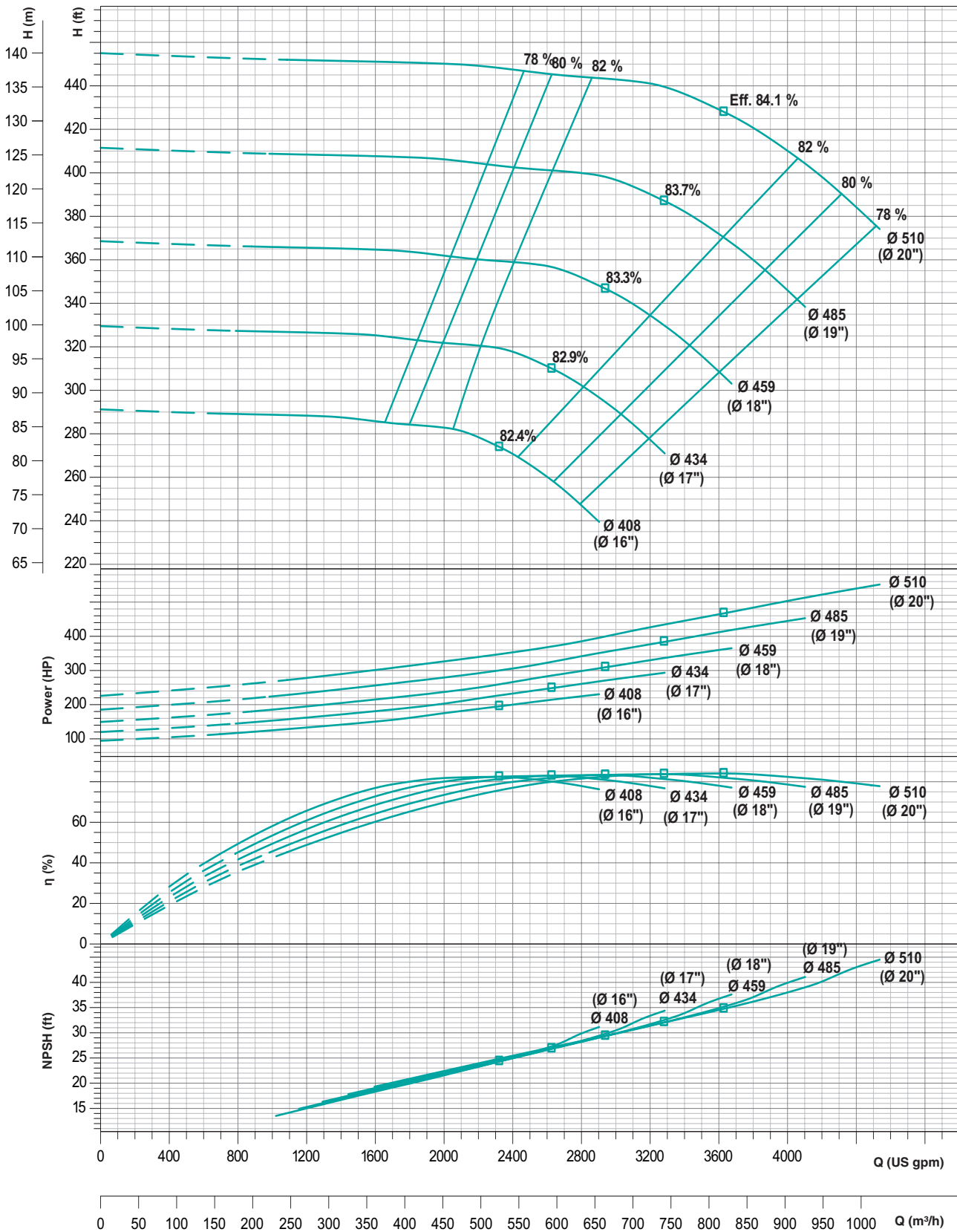

Performance curve tolerances are as per HI : 14.6 / ISO 9906, Grade 2B.
 Note : Performance curve are as per specific gravity and viscosity of water.

PERFORMANCE CURVES

Model : **THSC-200/570**

Speed : **1750 rpm**

Suc x Del (in mm) : **250 x 200**

Max. Impeller Ø : **570mm**

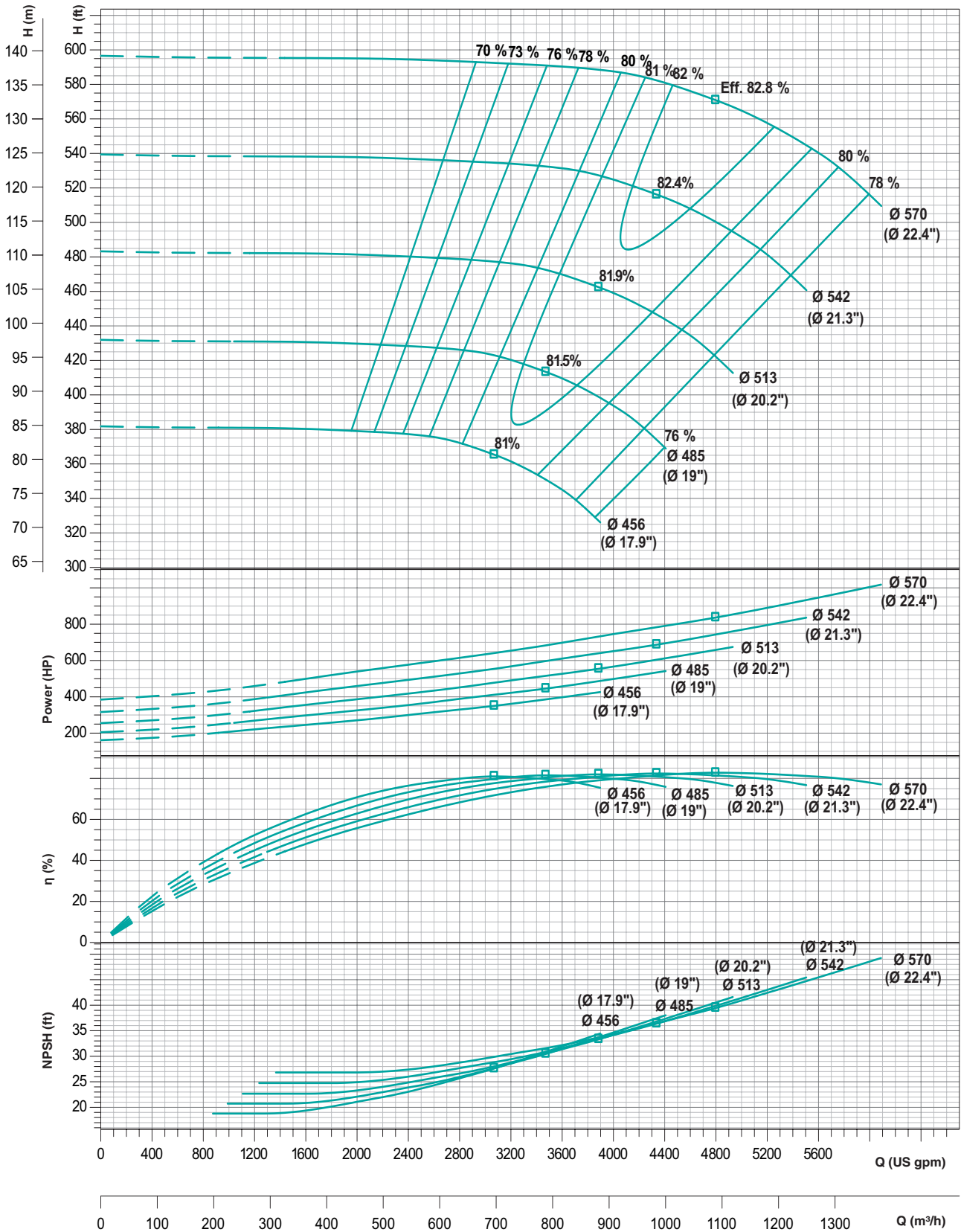

Performance curve tolerances are as per HI : 14.6 / ISO 9906, Grade 2B.
 Note : Performance curve are as per specific gravity and viscosity of water.

PERFORMANCE CURVES

Model : **THSC-125/335**

Speed : **1750 rpm**

Suc x Del (in mm) : **125 x 125**

Max. Impeller Ø : **337mm**

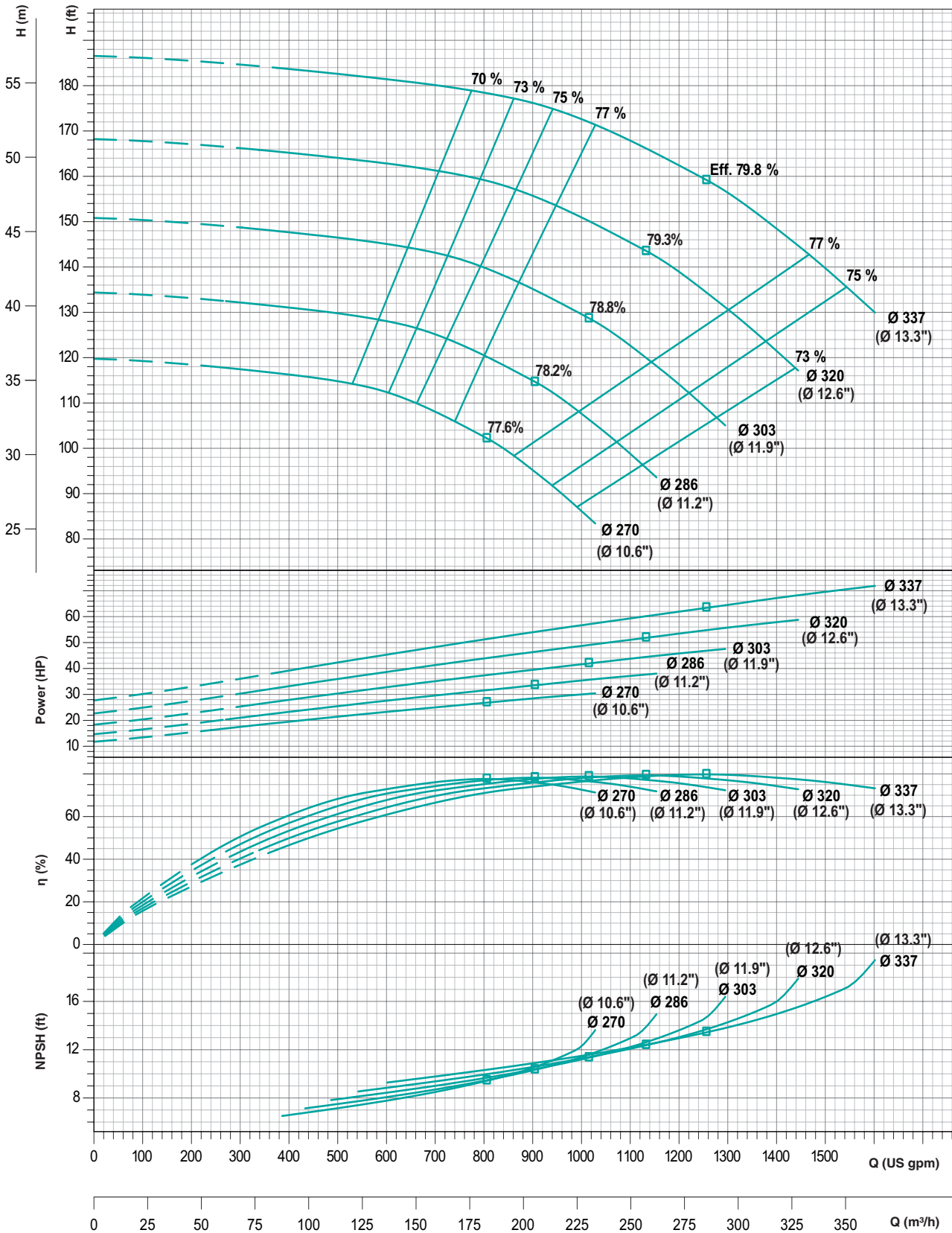

Performance curve tolerances are as per HI : 14.6 / ISO 9906, Grade 2B.
 Note : Performance curve are as per specific gravity and viscosity of water.

PERFORMANCE CURVES

Model : **THSC-125/380**

Speed : **1750 rpm**

Suc x Del (in mm) : **150 x 125**

Max. Impeller Ø : **379mm**

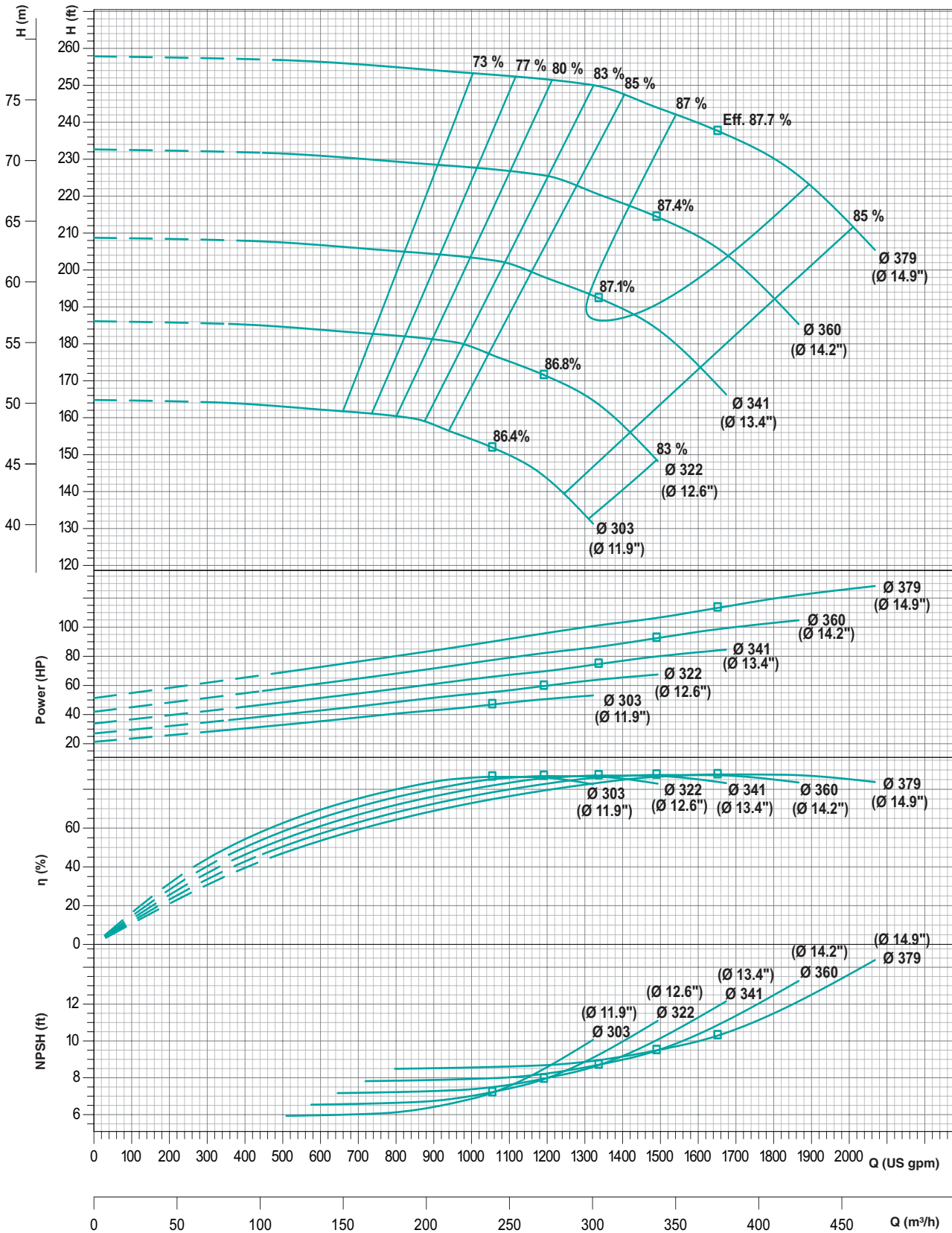

Performance curve tolerances are as per HI : 14.6 / ISO 9906, Grade 2B.

Note : Performance curve are as per specific gravity and viscosity of water.

PERFORMANCE CURVES

Model : **THSC-150/430**

Speed : **1750 rpm**

Suc x Del (in mm) : **200 x 150**

Max. Impeller Ø : **426mm**

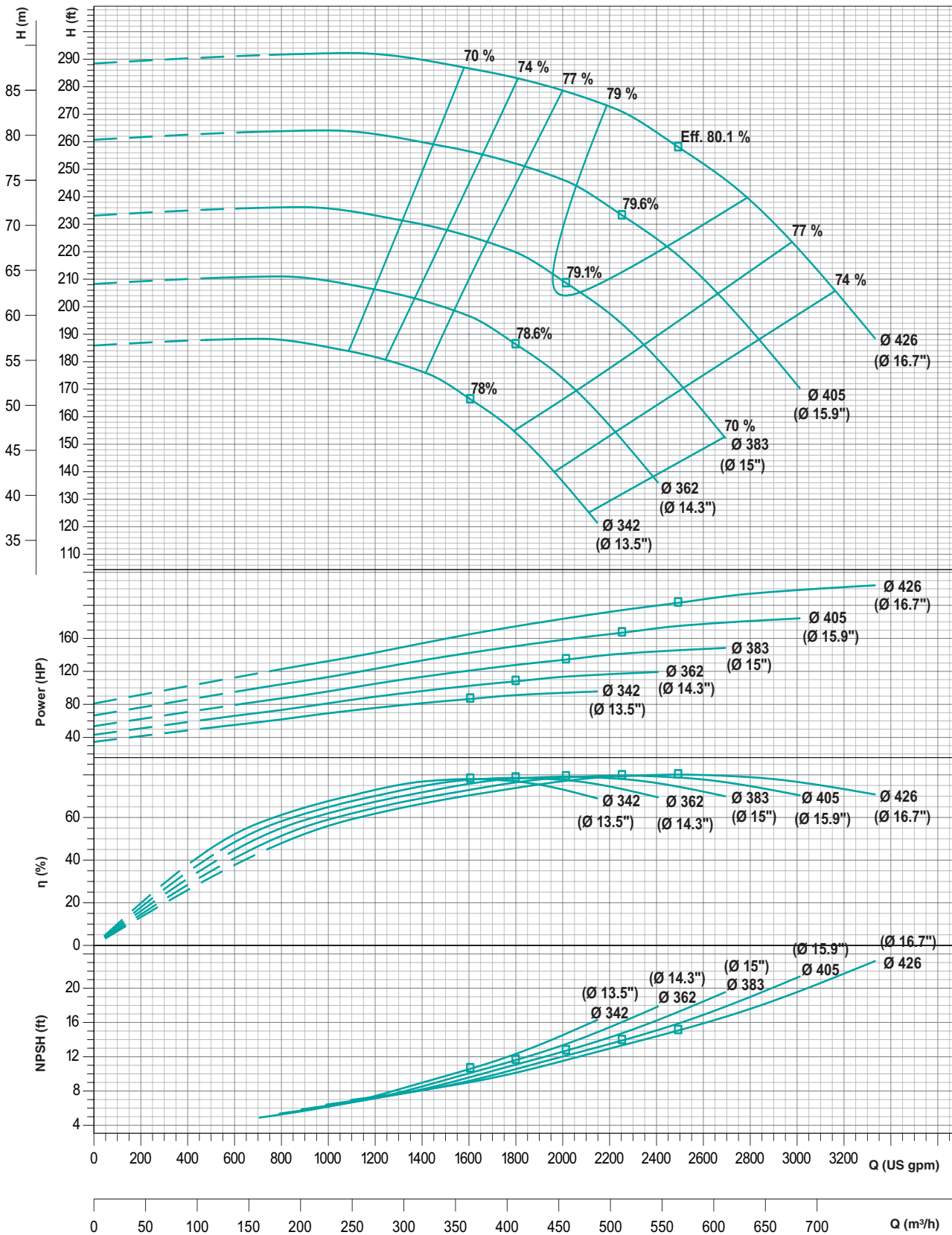

Performance curve tolerances are as per HI : 14.6 / ISO 9906, Grade 2B.
 Note : Performance curve are as per specific gravity and viscosity of water.

PERFORMANCE CURVES

Model : **THSC-200/460**

Speed : **1750 rpm**

Suc x Del (in mm) : **200 x 200**

Max. Impeller Ø : **460mm**

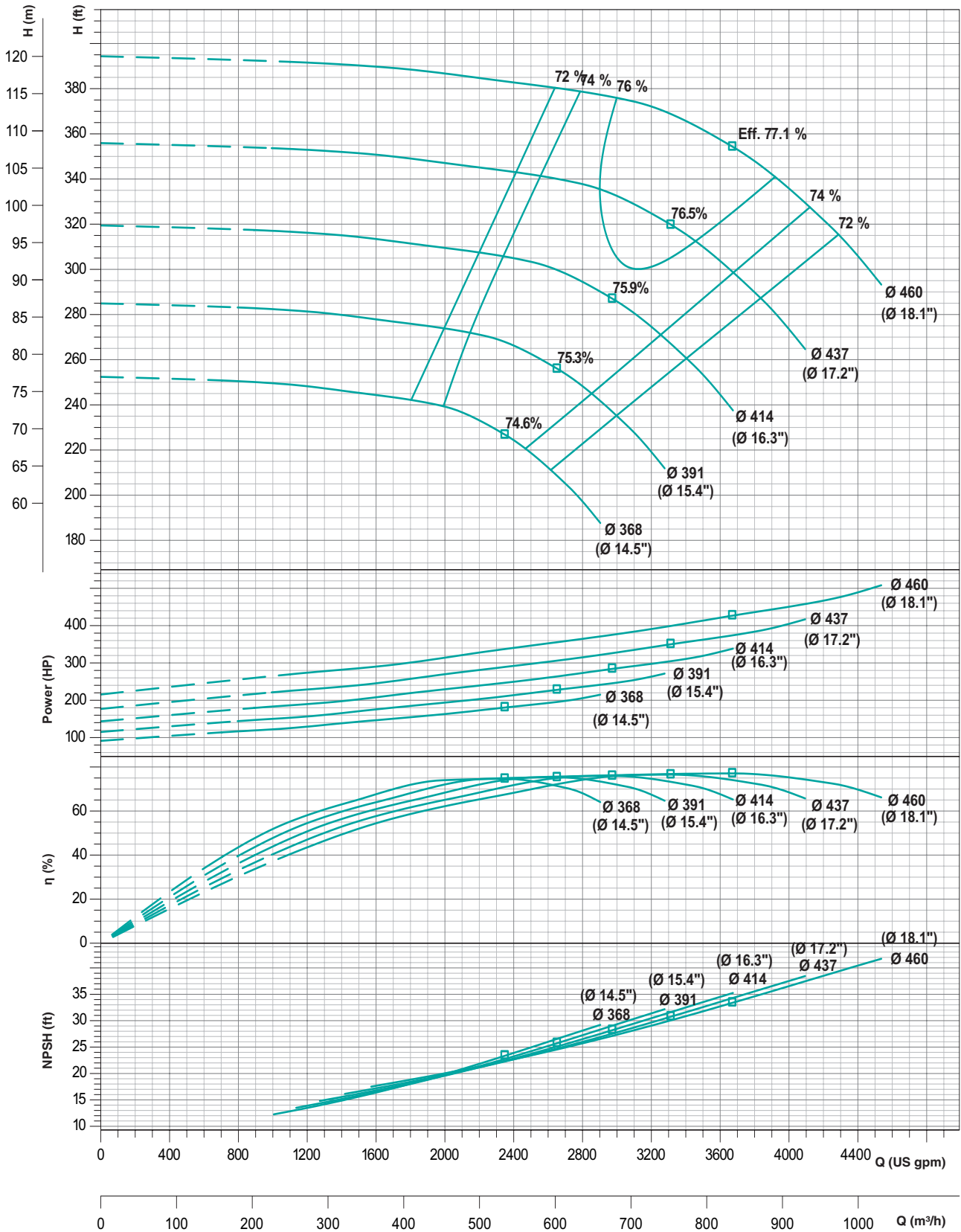

Performance curve tolerances are as per HI : 14.6 / ISO 9906, Grade 2B.
 Note : Performance curve are as per specific gravity and viscosity of water.

PERFORMANCE CURVES

Model : **THSC-200/540**

Speed : **1750 rpm**

Suc x Del (in mm) : **250 x 200**

Max. Impeller Ø : **538.2mm**

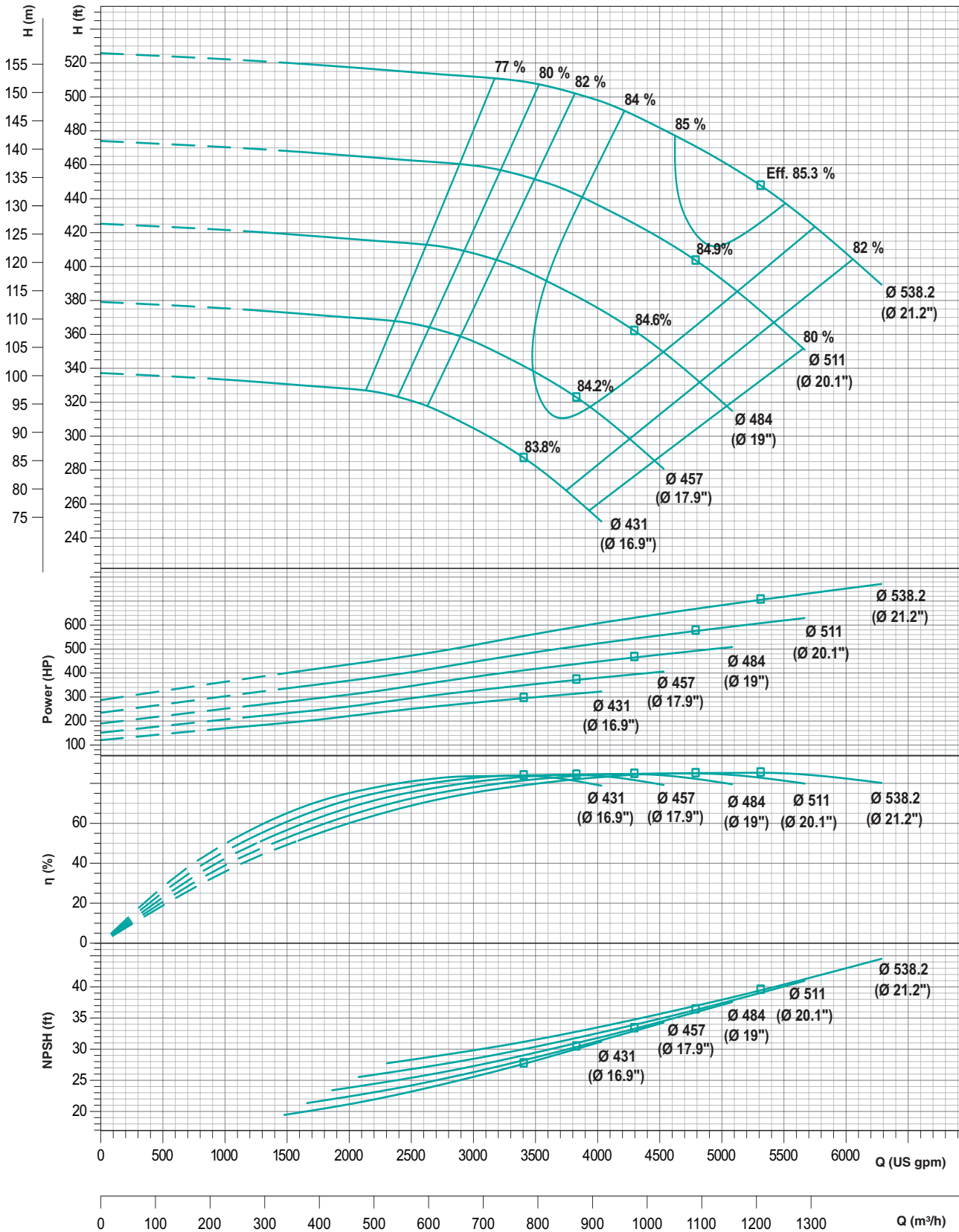

Performance curve tolerances are as per HI : 14.6 / ISO 9906, Grade 2B.
 Note : Performance curve are as per specific gravity and viscosity of water.

PERFORMANCE CURVES

Model : **THSC-125/340**

Speed : **1750 rpm**

Suc x Del (in mm) : **150 x 125**

Max. Impeller Ø : **337mm**

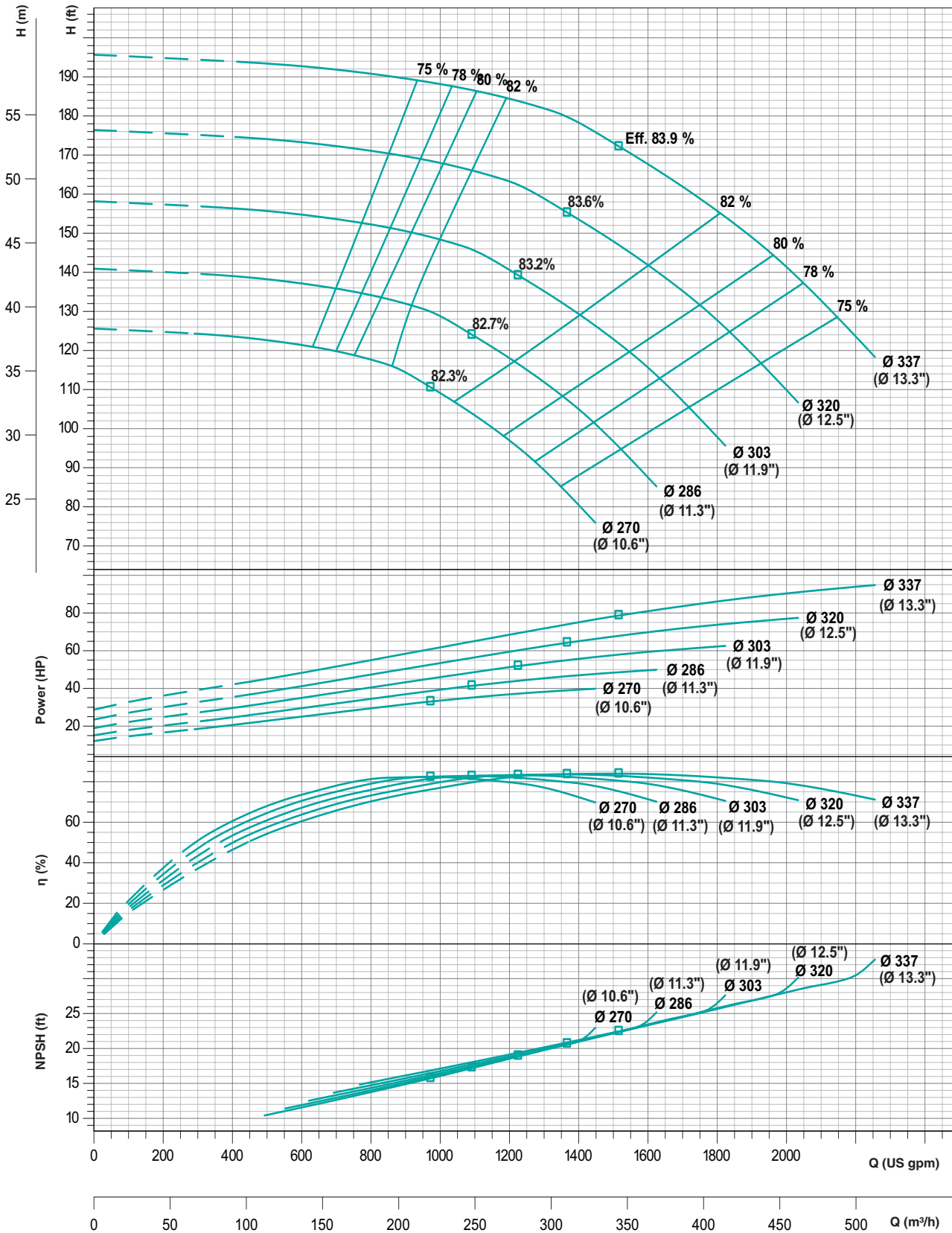

Performance curve tolerances are as per HI : 14.6 / ISO 9906, Grade 2B.
 Note : Performance curve are as per specific gravity and viscosity of water.

PERFORMANCE CURVES

Model : **THSC-150/380**

Speed : **1750 rpm**

Suc x Del (in mm) : **200 x 150**

Max. Impeller Ø : **379mm**

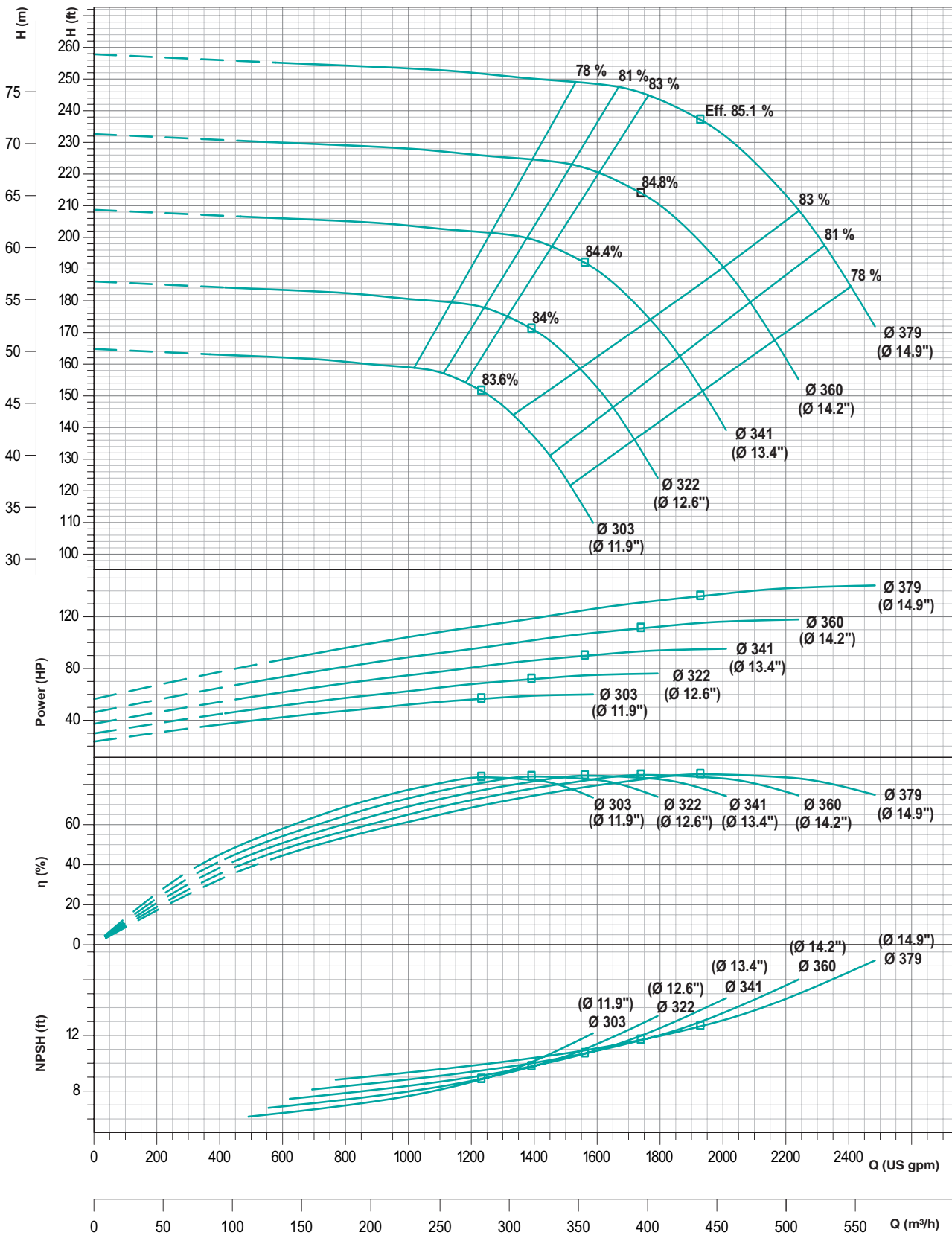

Performance curve tolerances are as per HI : 14.6 / ISO 9906, Grade 2B.
 Note : Performance curve are as per specific gravity and viscosity of water.

PERFORMANCE CURVES

Model : **THSC-200/430**

Speed : **1750 rpm**

Suc x Del (in mm) : **200 x 200**

Max. Impeller Ø : **426mm**

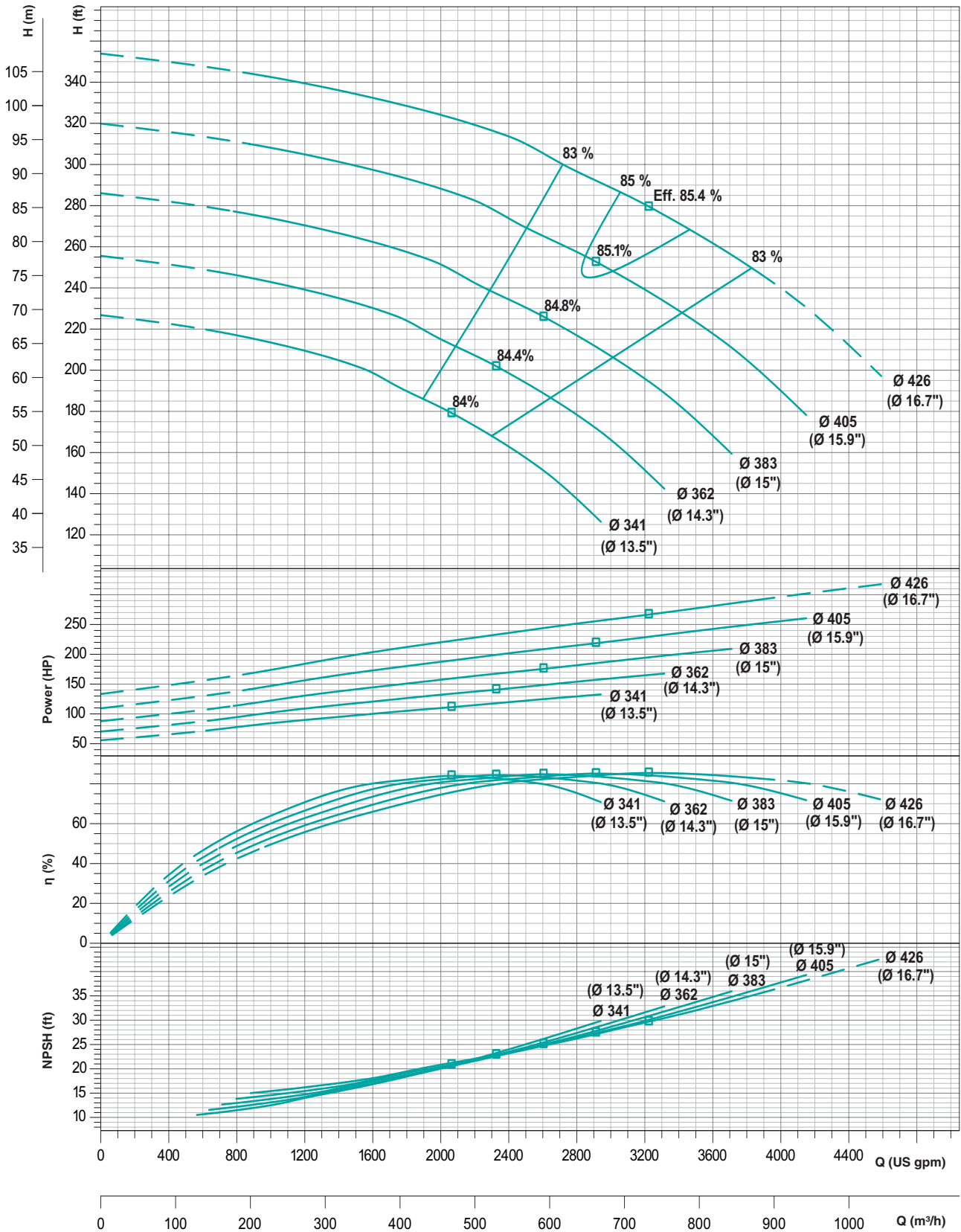

Performance curve tolerances are as per HI : 14.6 / ISO 9906, Grade 2B.
 Note : Performance curve are as per specific gravity and viscosity of water.

PERFORMANCE CURVES

Model : **THSC-250/475**

Speed : **1750 rpm**

Suc x Del (in mm) : **250 x 250**

Max. Impeller Ø : **478.8mm**

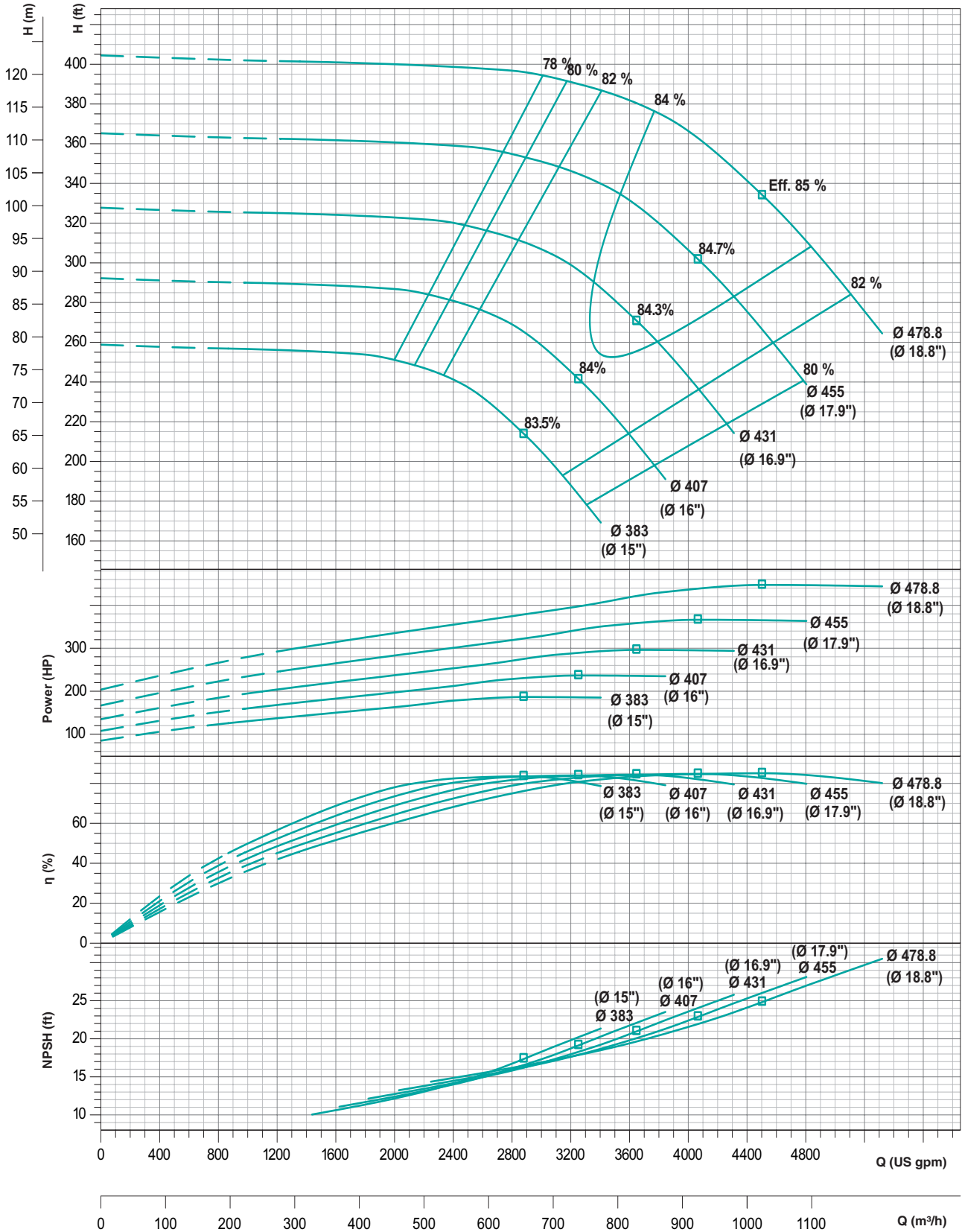

Performance curve tolerances are as per HI : 14.6 / ISO 9906, Grade 2B.
 Note : Performance curve are as per specific gravity and viscosity of water.

PERFORMANCE CURVES

Model : **THSC-250/540**

Speed : **1750 rpm**

Suc x Del (in mm) : **300 x 250**

Max. Impeller Ø : **538.2mm**

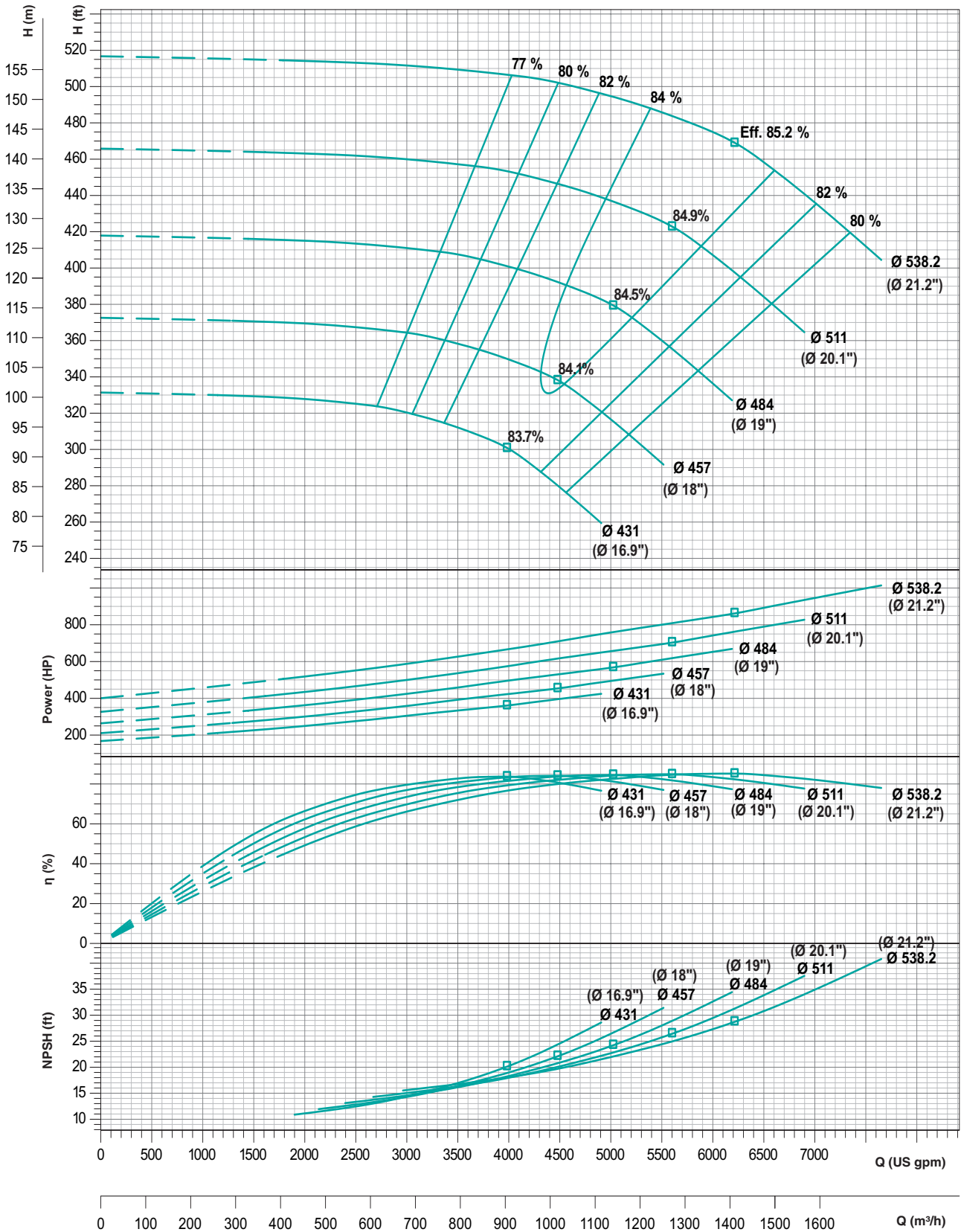

Performance curve tolerances are as per HI : 14.6 / ISO 9906, Grade 2B.
 Note : Performance curve are as per specific gravity and viscosity of water.

PERFORMANCE CURVES

Model : **THSC-150/340**

Speed : **1750 rpm**

Suc x Del (in mm) : **200 x 150**

Max. Impeller Ø : **337mm**

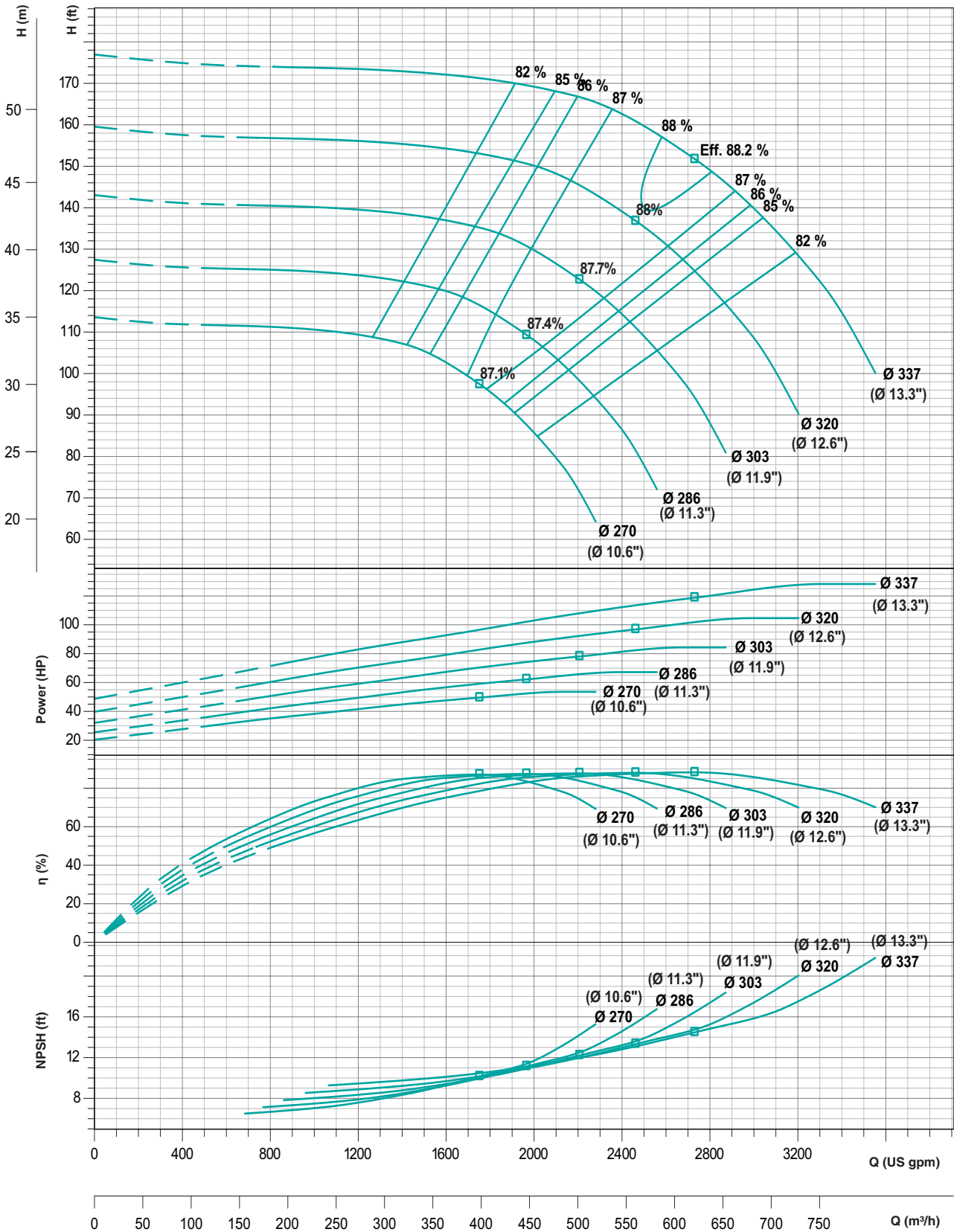

Performance curve tolerances are as per HI : 14.6 / ISO 9906, Grade 2B.
 Note : Performance curve are as per specific gravity and viscosity of water.

PERFORMANCE CURVES

Model : **THSC-200/380**

Speed : **1750 rpm**

Suc x Del (in mm) : **200 x 200**

Max. Impeller Ø : **379mm**

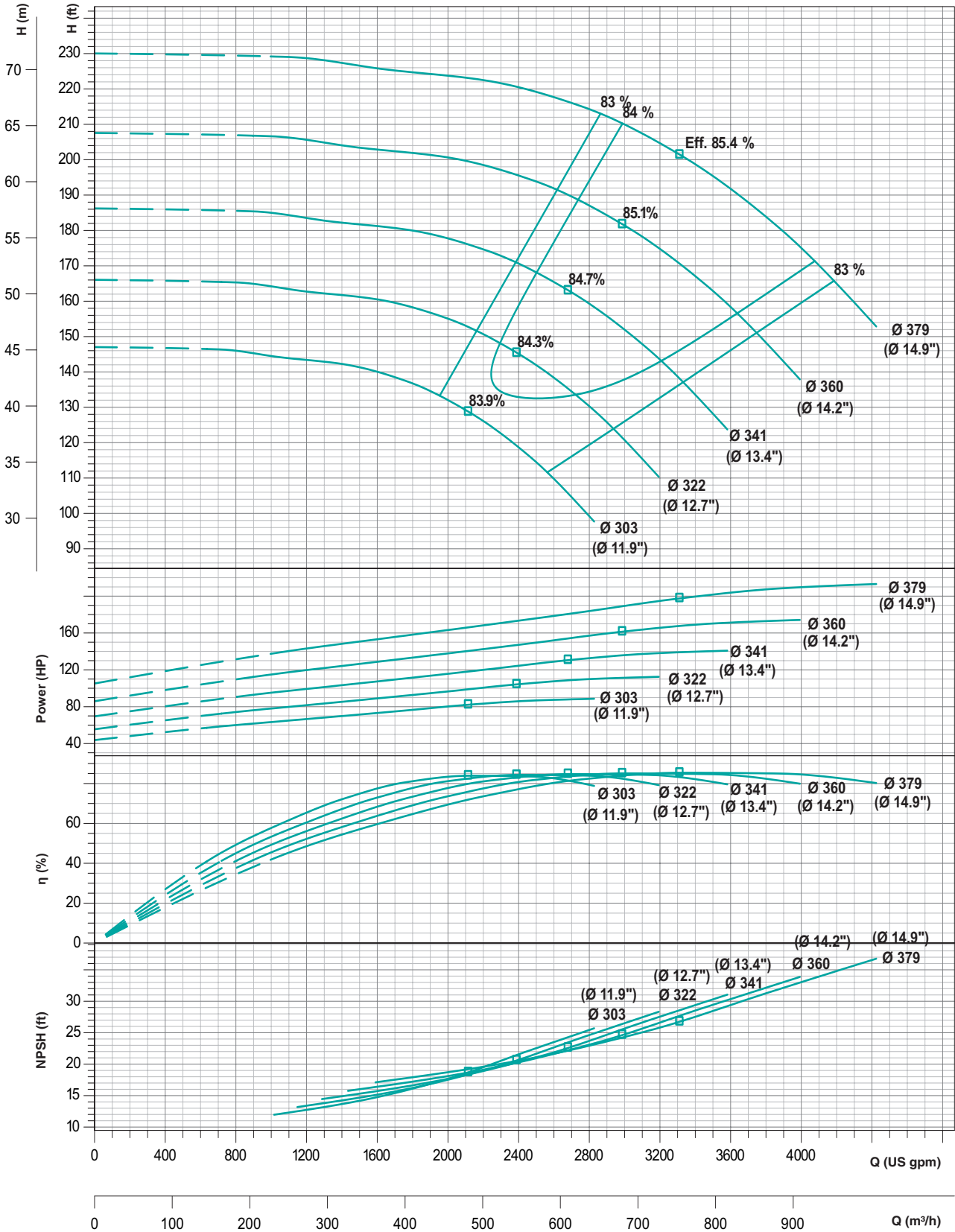

Performance curve tolerances are as per HI : 14.6 / ISO 9906, Grade 2B.
 Note : Performance curve are as per specific gravity and viscosity of water.

PERFORMANCE CURVES

Model : **THSC-250/425**

Speed : **1750 rpm**

Suc x Del (in mm) : **250 x 250**

Max. Impeller Ø : **426mm**

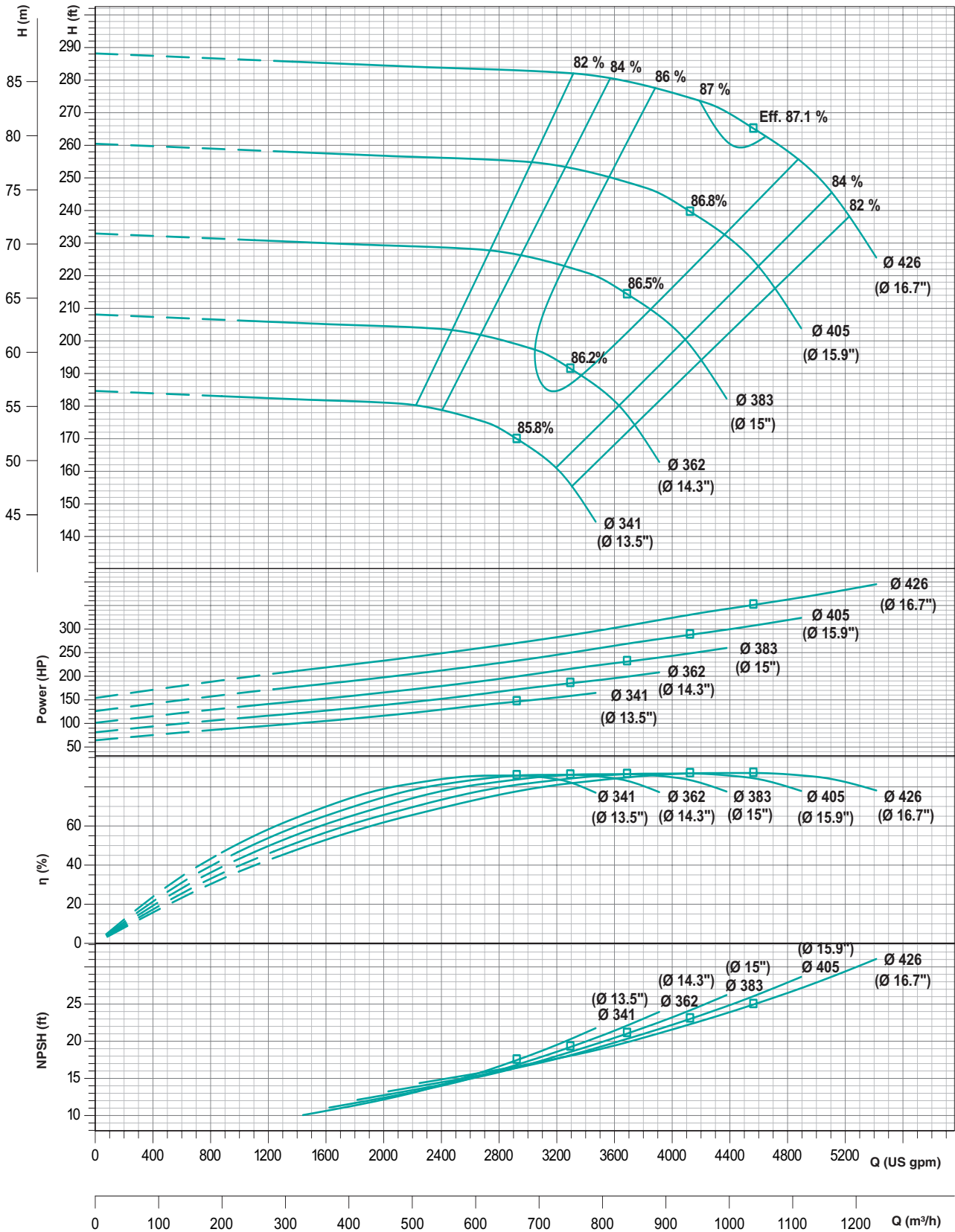

Performance curve tolerances are as per HI : 14.6 / ISO 9906, Grade 2B.
 Note : Performance curve are as per specific gravity and viscosity of water.

PERFORMANCE CURVES

Model : **THSC-250/480**

Speed : **1750 rpm**

Suc x Del (in mm) : **300 x 250**

Max. Impeller Ø : **478.8mm**

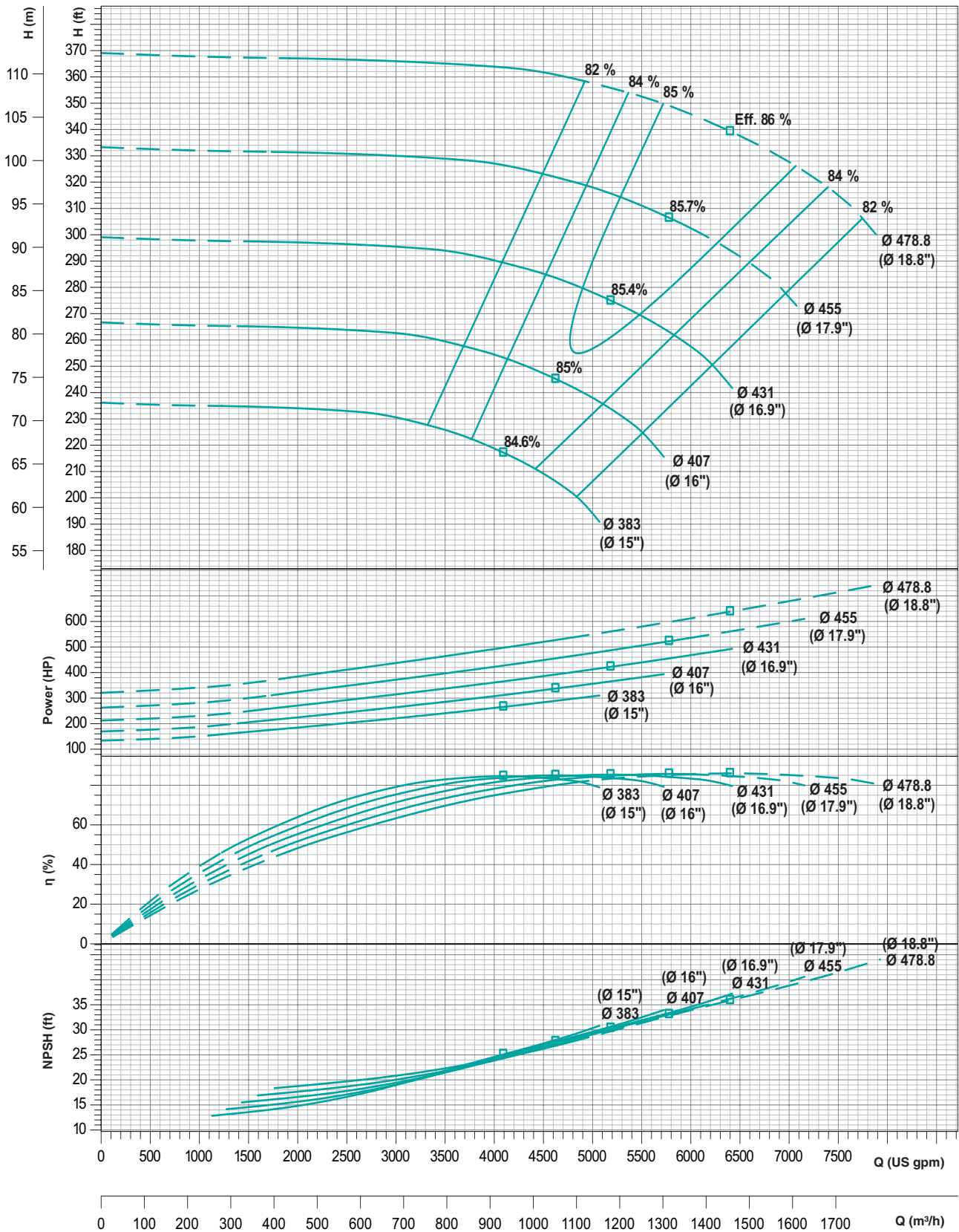

Performance curve tolerances are as per HI : 14.6 / ISO 9906, Grade 2B.

Note : Performance curve are as per specific gravity and viscosity of water.

PERFORMANCE CURVES

Model : **THSC-300/540**

Speed : **1750 rpm**

Suc x Del (in mm) : **350 x 300**

Max. Impeller Ø : **538.2mm**

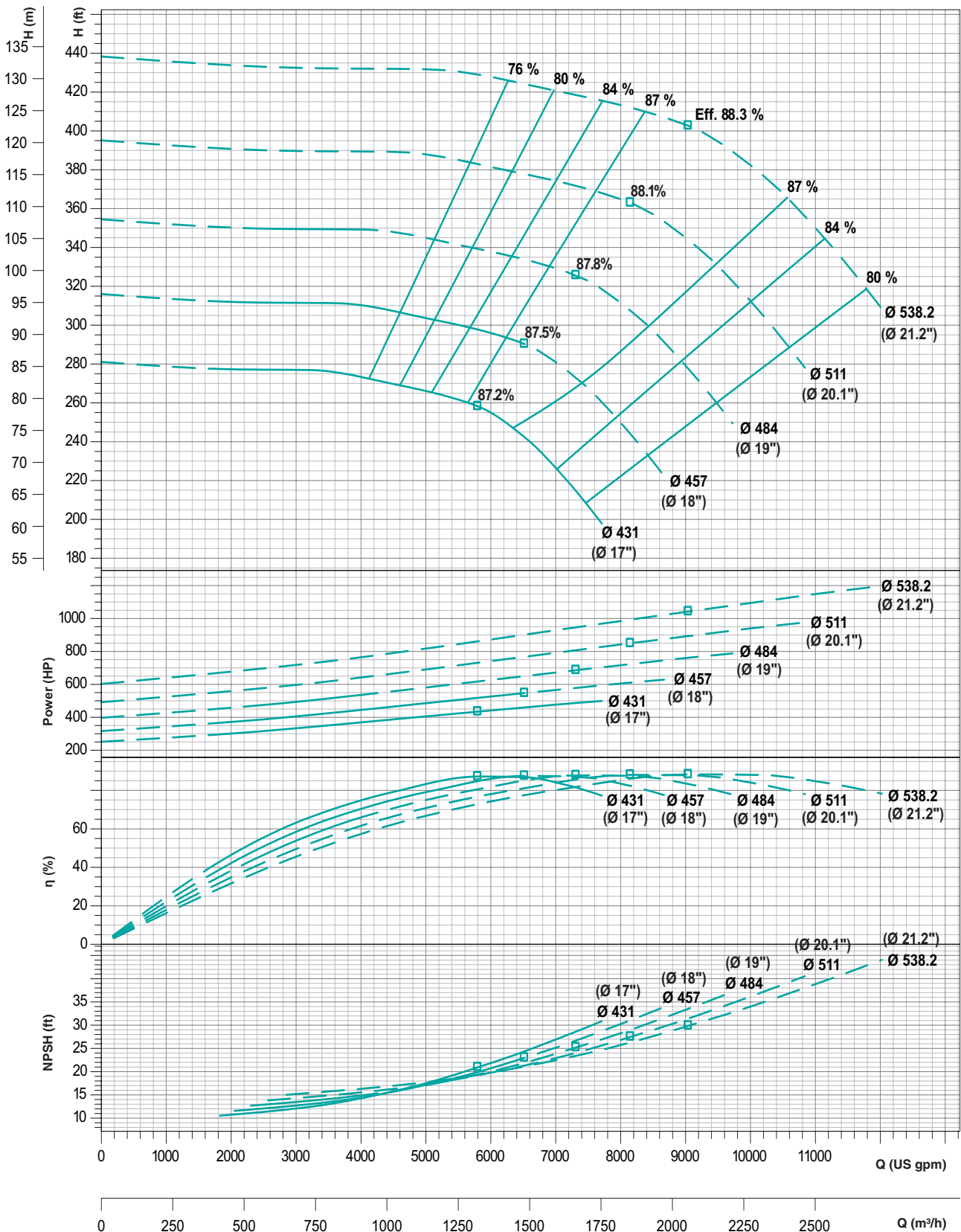

Performance curve tolerances are as per HI : 14.6 / ISO 9906, Grade 2B.
 Note : Performance curve are as per specific gravity and viscosity of water.

PERFORMANCE CURVES

Model : **THSC-200/340**

Speed : **1750 rpm**

Suc x Del (in mm) : **200 x 200**

Max. Impeller Ø : **337mm**

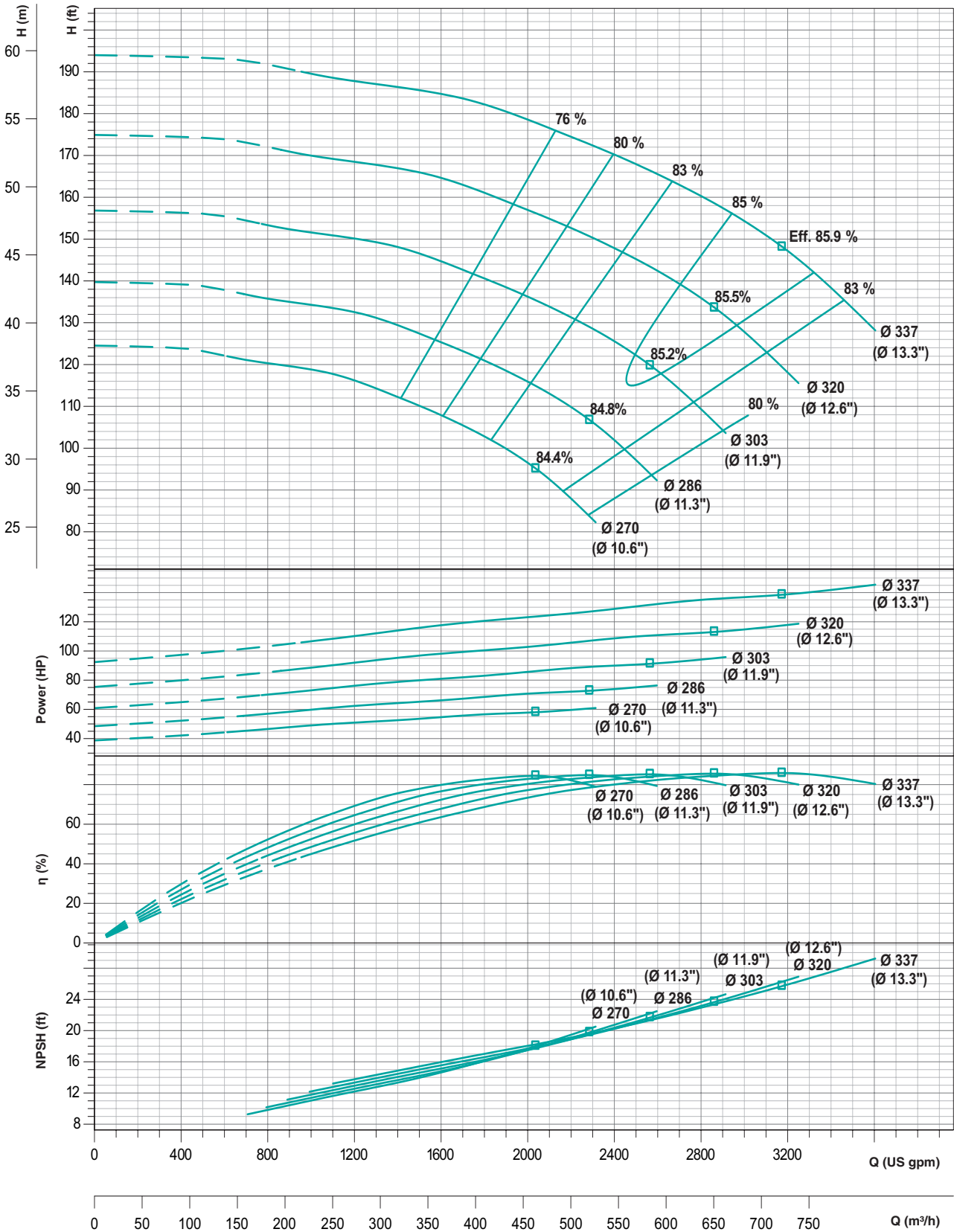

Performance curve tolerances are as per HI : 14.6 / ISO 9906, Grade 2B.

Note : Performance curve are as per specific gravity and viscosity of water.

PERFORMANCE CURVES

Model : **THSC-250/380**

Speed : **1750 rpm**

Suc x Del (in mm) : **250 x 250**

Max. Impeller Ø : **379mm**

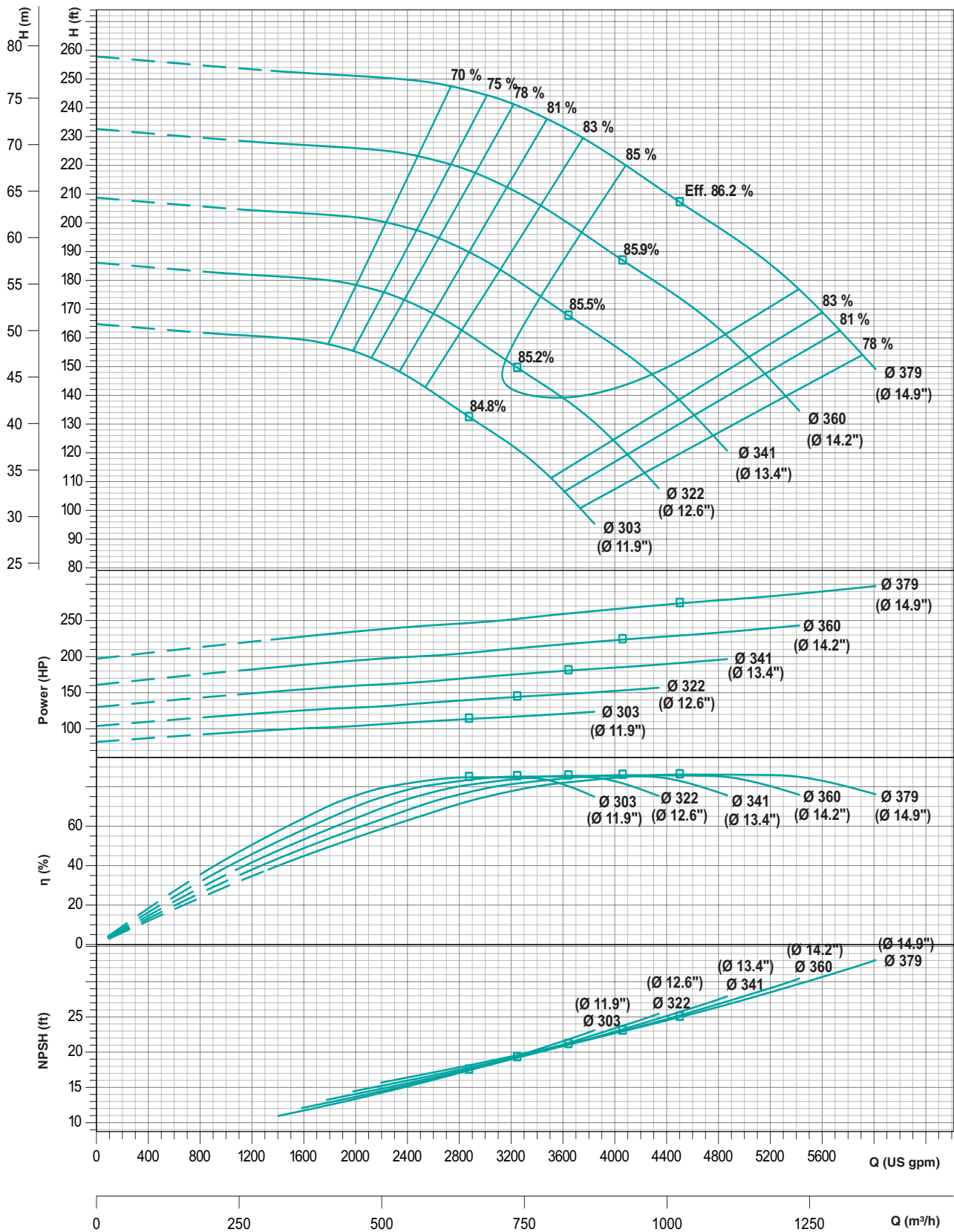

Performance curve tolerances are as per HI : 14.6 / ISO 9906, Grade 2B.
 Note : Performance curve are as per specific gravity and viscosity of water.

PERFORMANCE CURVES

Model : **THSC-250/430**

Speed : **1750 rpm**

Suc x Del (in mm) : **300 x 250**

Max. Impeller Ø : **426mm**

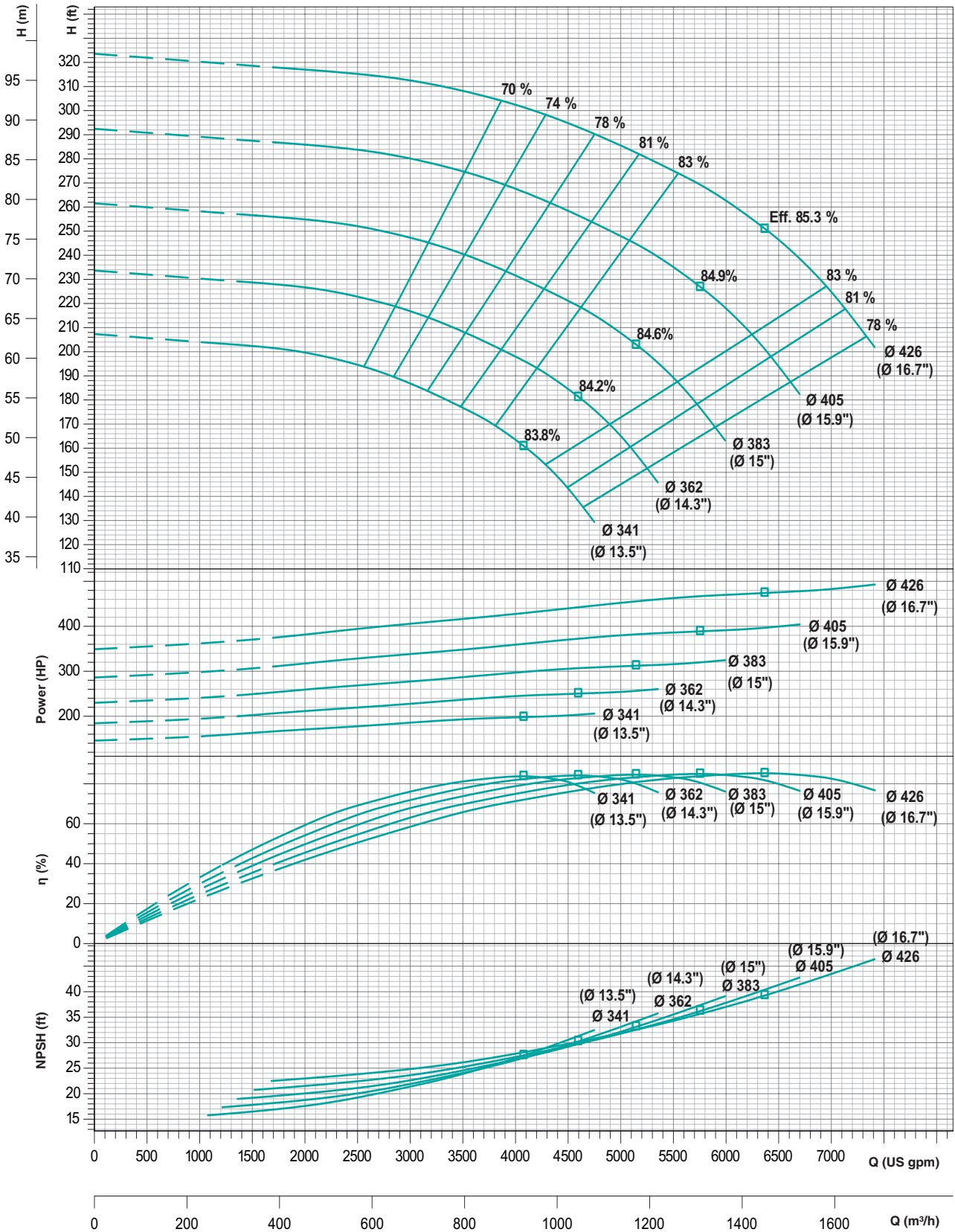

Performance curve tolerances are as per HI : 14.6 / ISO 9906, Grade 2B.
 Note : Performance curve are as per specific gravity and viscosity of water.

PERFORMANCE CURVES

Model : **THSC-300/480**

Speed : **1750 rpm**

Suc x Del (in mm) : **350 x 300**

Max. Impeller Ø : **478.8mm**

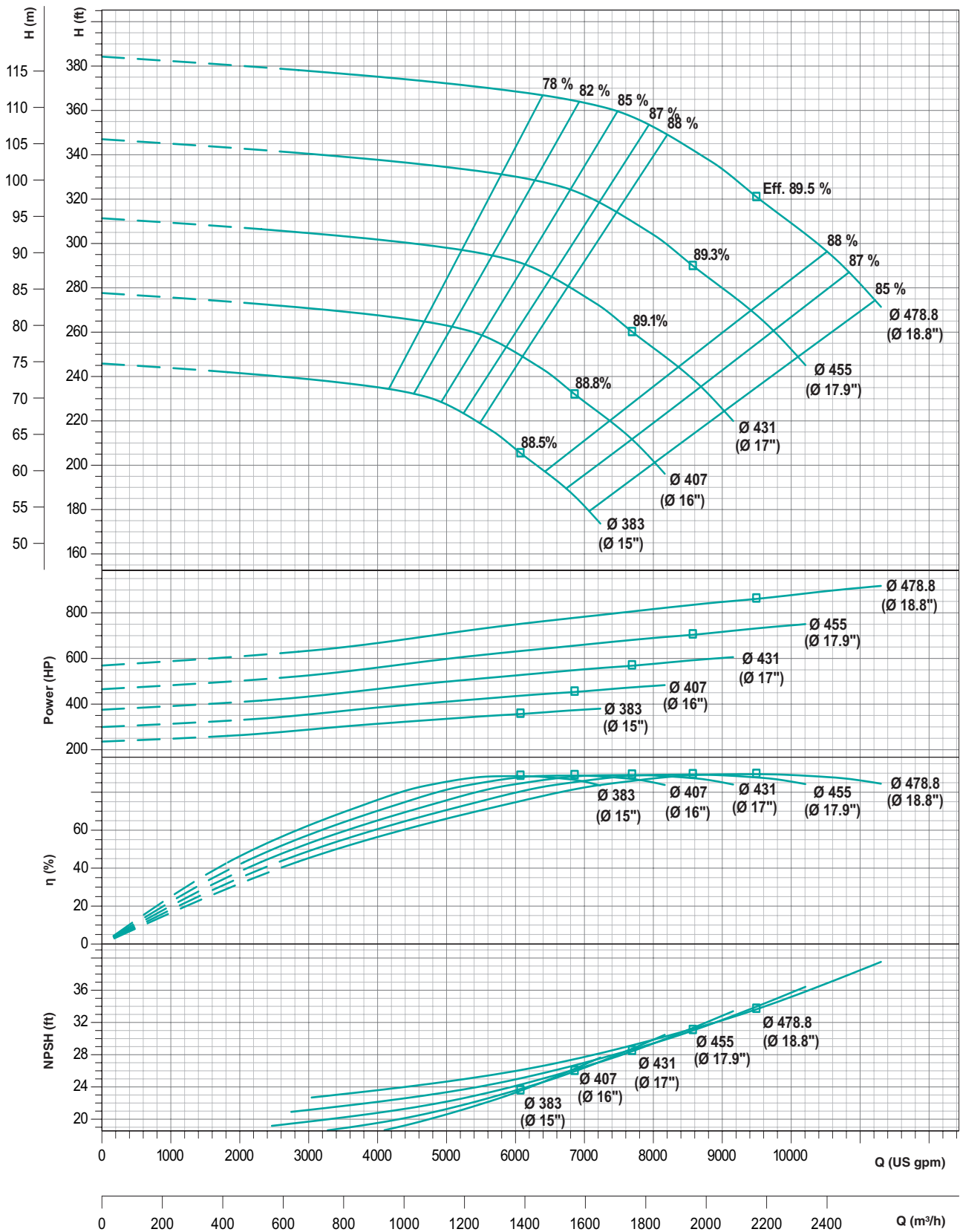

Performance curve tolerances are as per HI : 14.6 / ISO 9906, Grade 2B.
 Note : Performance curve are as per specific gravity and viscosity of water.

PERFORMANCE CURVES

Model : **THSC-350/560**

Speed : **1750 rpm**

Suc x Del (in mm) : **400 x 350**

Max. Impeller Ø : **556mm**

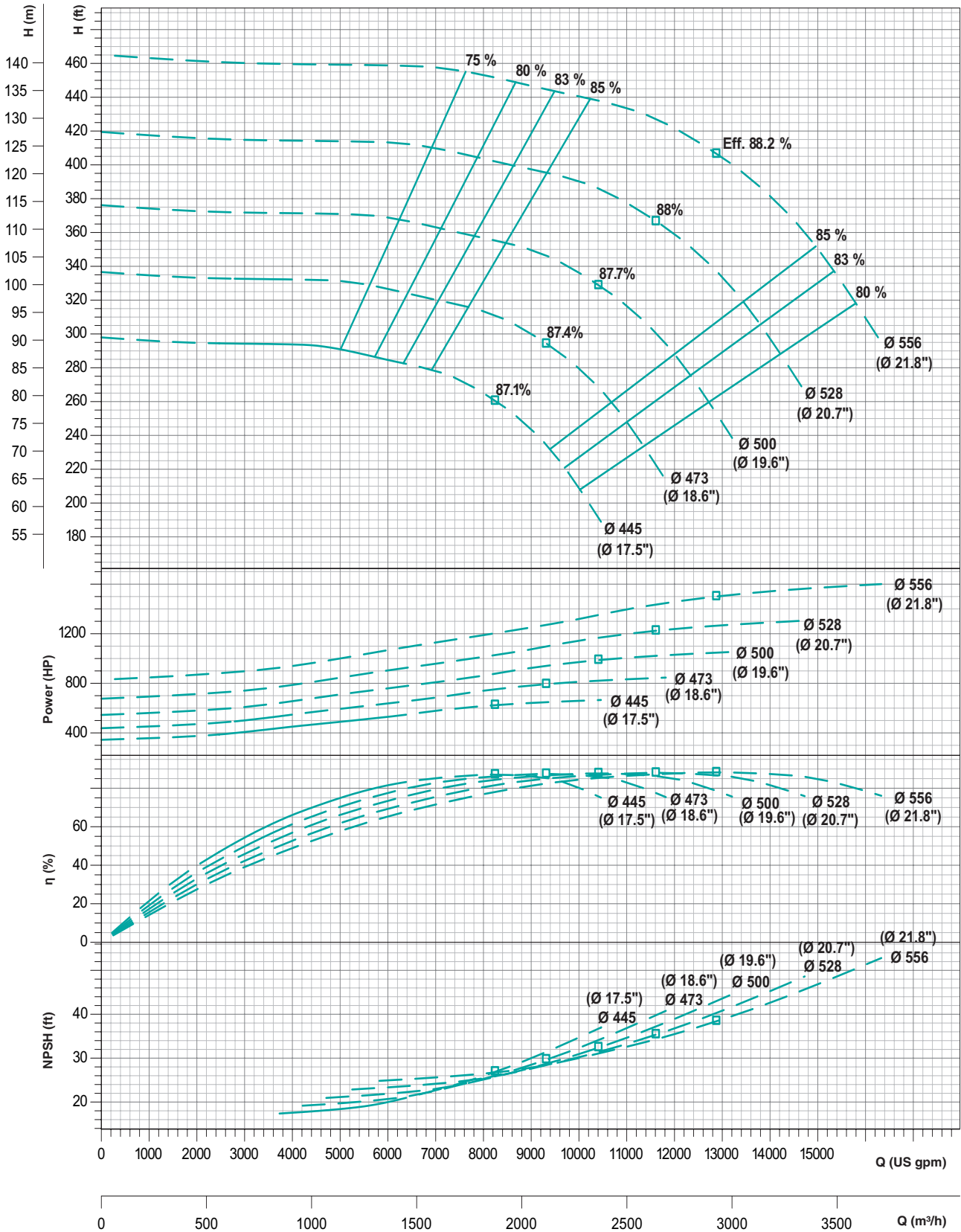

Performance curve tolerances are as per HI : 14.6 / ISO 9906, Grade 2B.
 Note : Performance curve are as per specific gravity and viscosity of water.

PERFORMANCE CURVES

Model : **THSC-250/360**

Speed : **1750 rpm**

Suc x Del (in mm) : **250 x 250**

Max. Impeller Ø : **360mm**

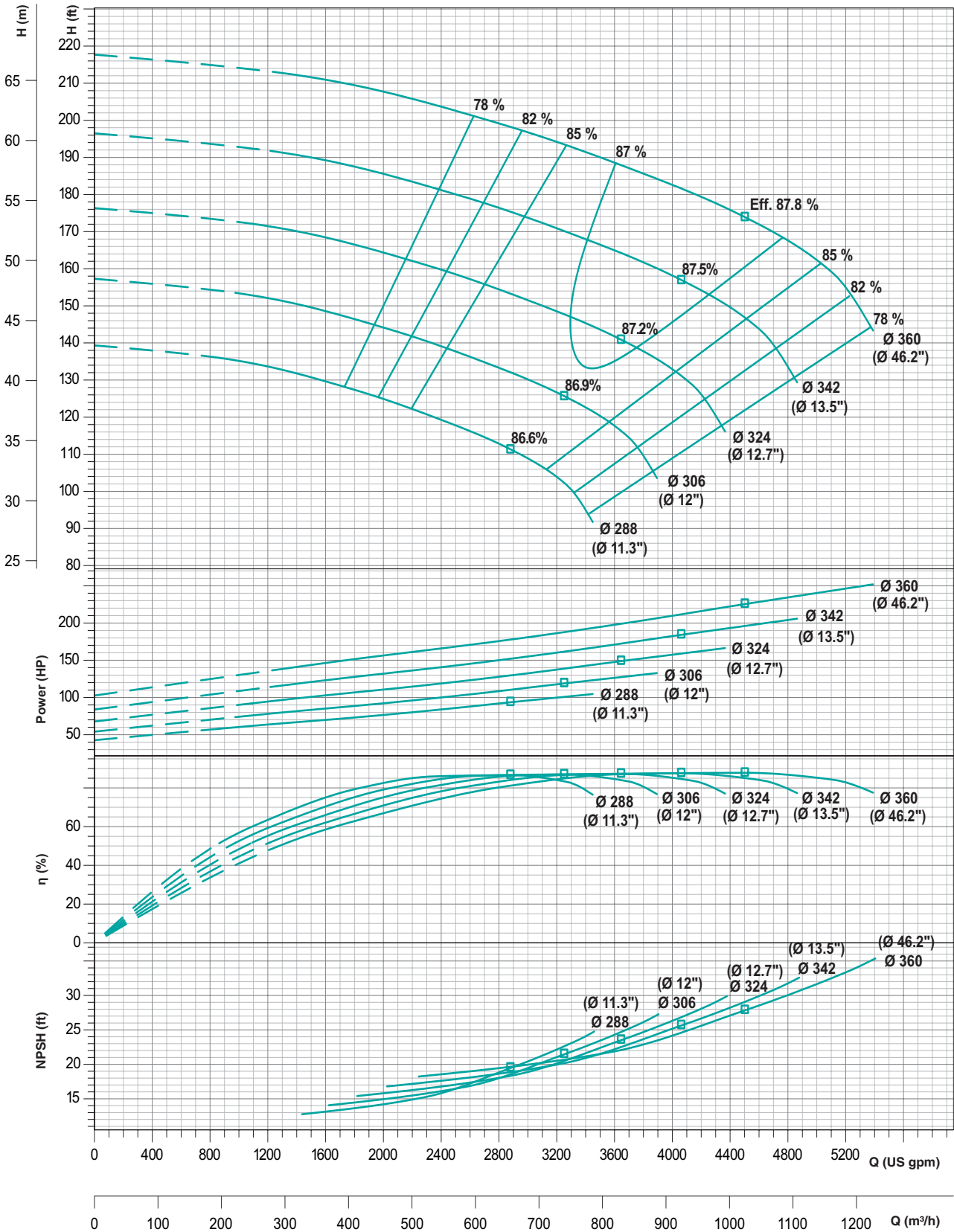

Performance curve tolerances are as per HI : 14.6 / ISO 9906, Grade 2B.
 Note : Performance curve are as per specific gravity and viscosity of water.

PERFORMANCE CURVES

Model : **THSC-250/400**

Speed : **1750 rpm**

Suc x Del (in mm) : **300 x 250**

Max. Impeller Ø : **404mm**

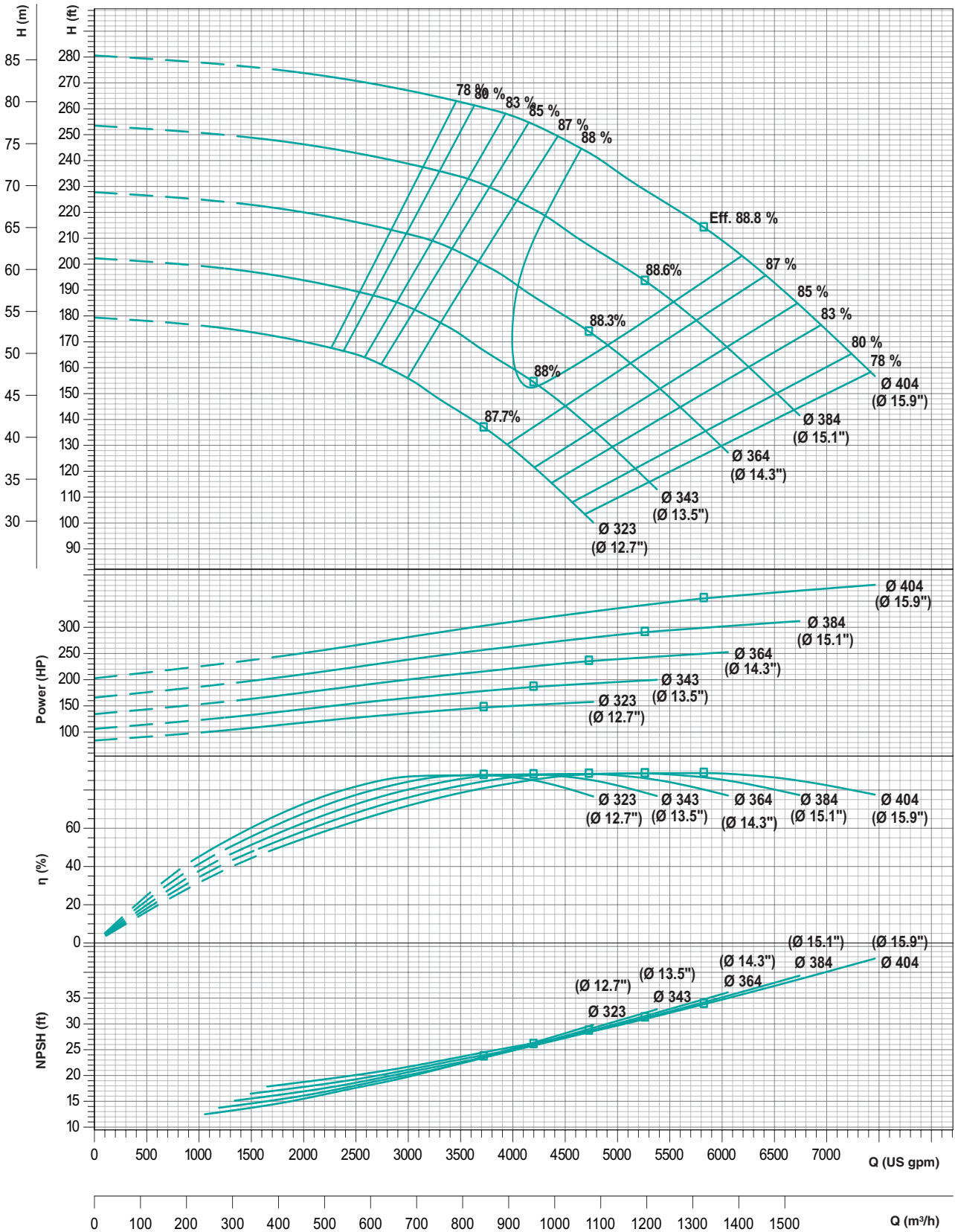

Performance curve tolerances are as per HI : 14.6 / ISO 9906, Grade 2B.
 Note : Performance curve are as per specific gravity and viscosity of water.

PERFORMANCE CURVES

Model : **THSC-300/450**

Speed : **1750 rpm**

Suc x Del (in mm) : **350 x 300**

Max. Impeller Ø : **454.4mm**

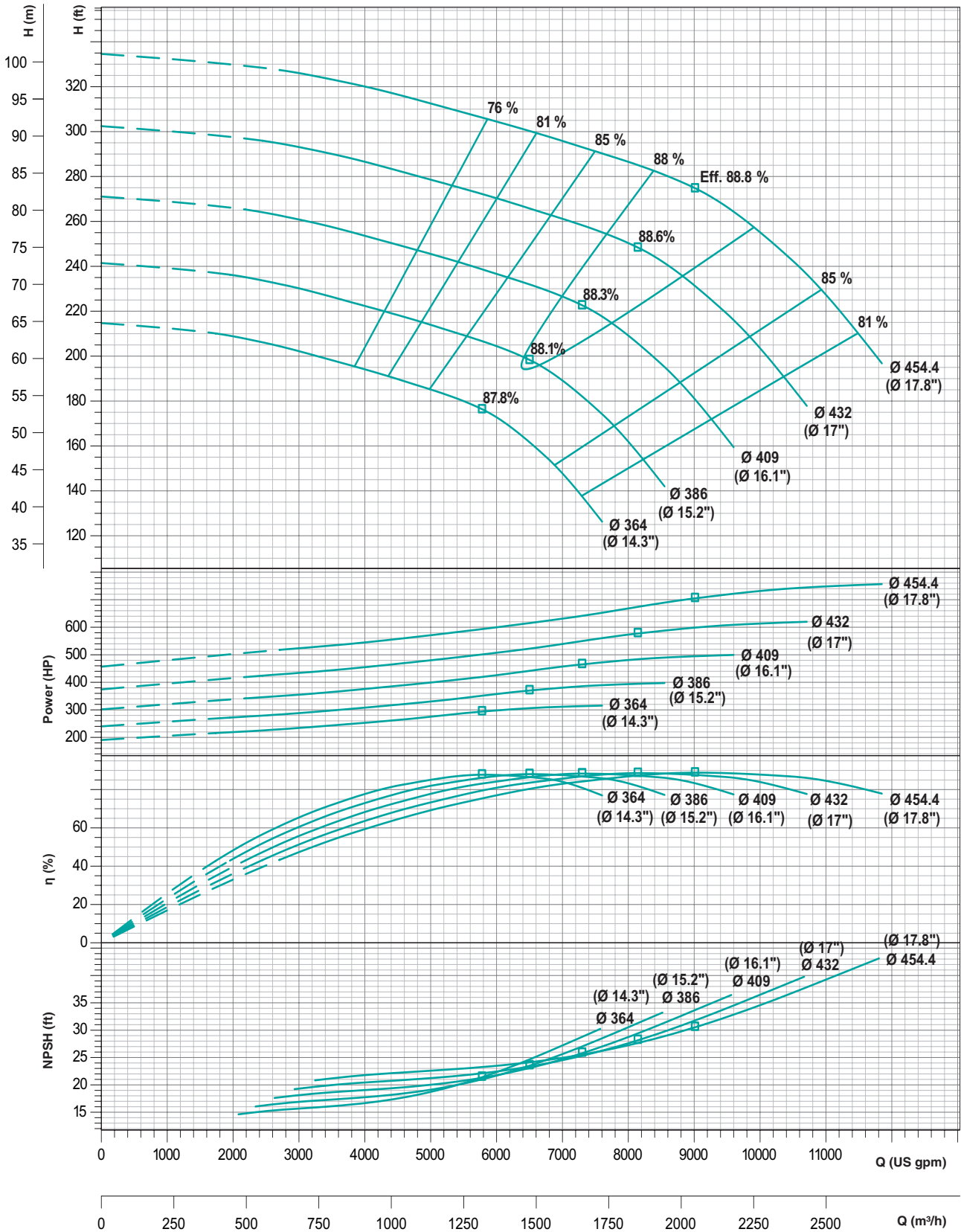

Performance curve tolerances are as per HI : 14.6 / ISO 9906, Grade 2B.
 Note : Performance curve are as per specific gravity and viscosity of water.

PERFORMANCE CURVES

Model : **THSC-400/510**

Speed : **1750 rpm**

Suc x Del (in mm) : **400 x 400**

Max. Impeller Ø : **511mm**

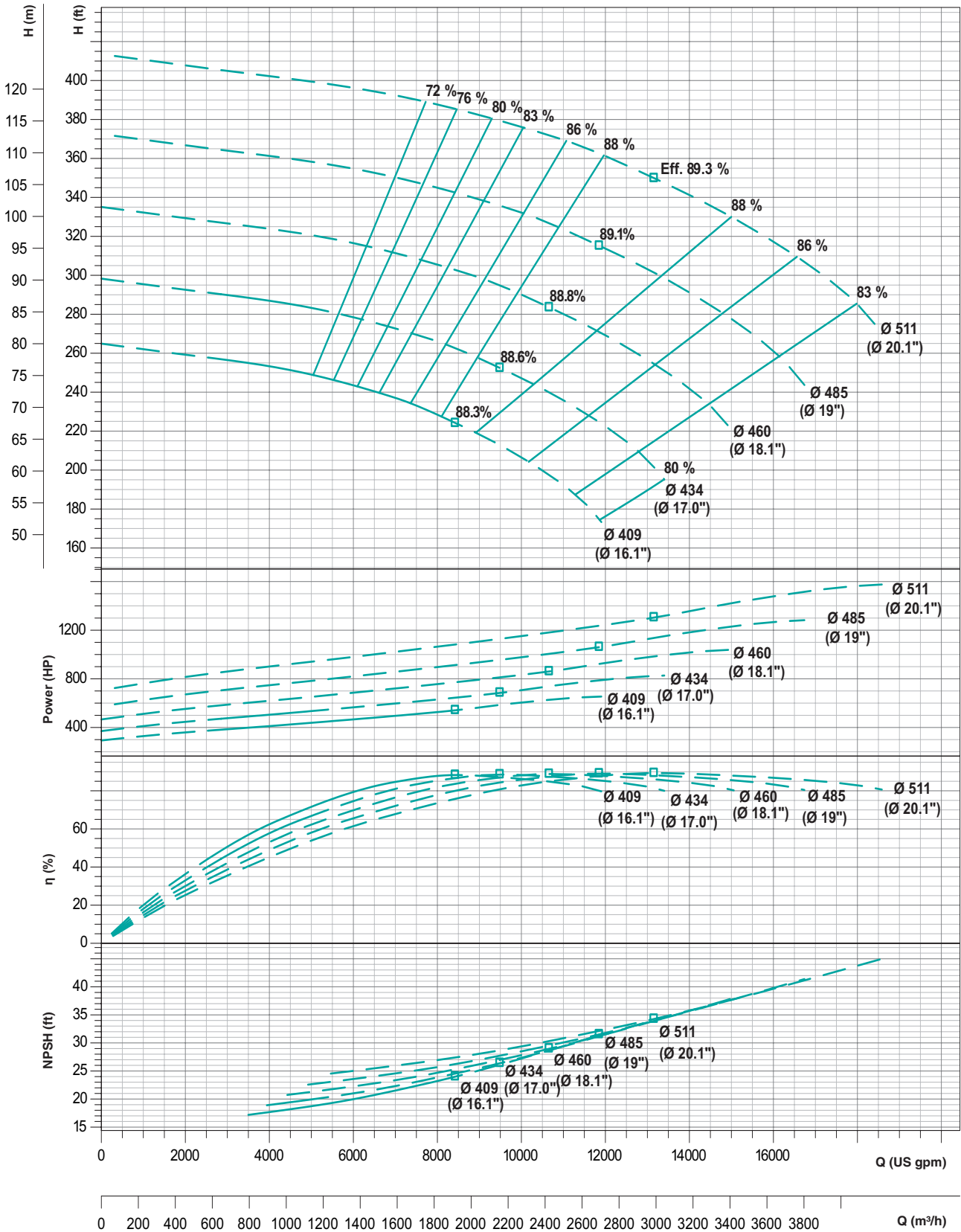

Performance curve tolerances are as per HI : 14.6 / ISO 9906, Grade 2B.
 Note : Performance curve are as per specific gravity and viscosity of water.

PERFORMANCE CURVES

Model : **THSC-300/370**

Speed : **1750 rpm**

Suc x Del (in mm) : **300 x 300**

Max. Impeller Ø : **370.9mm**

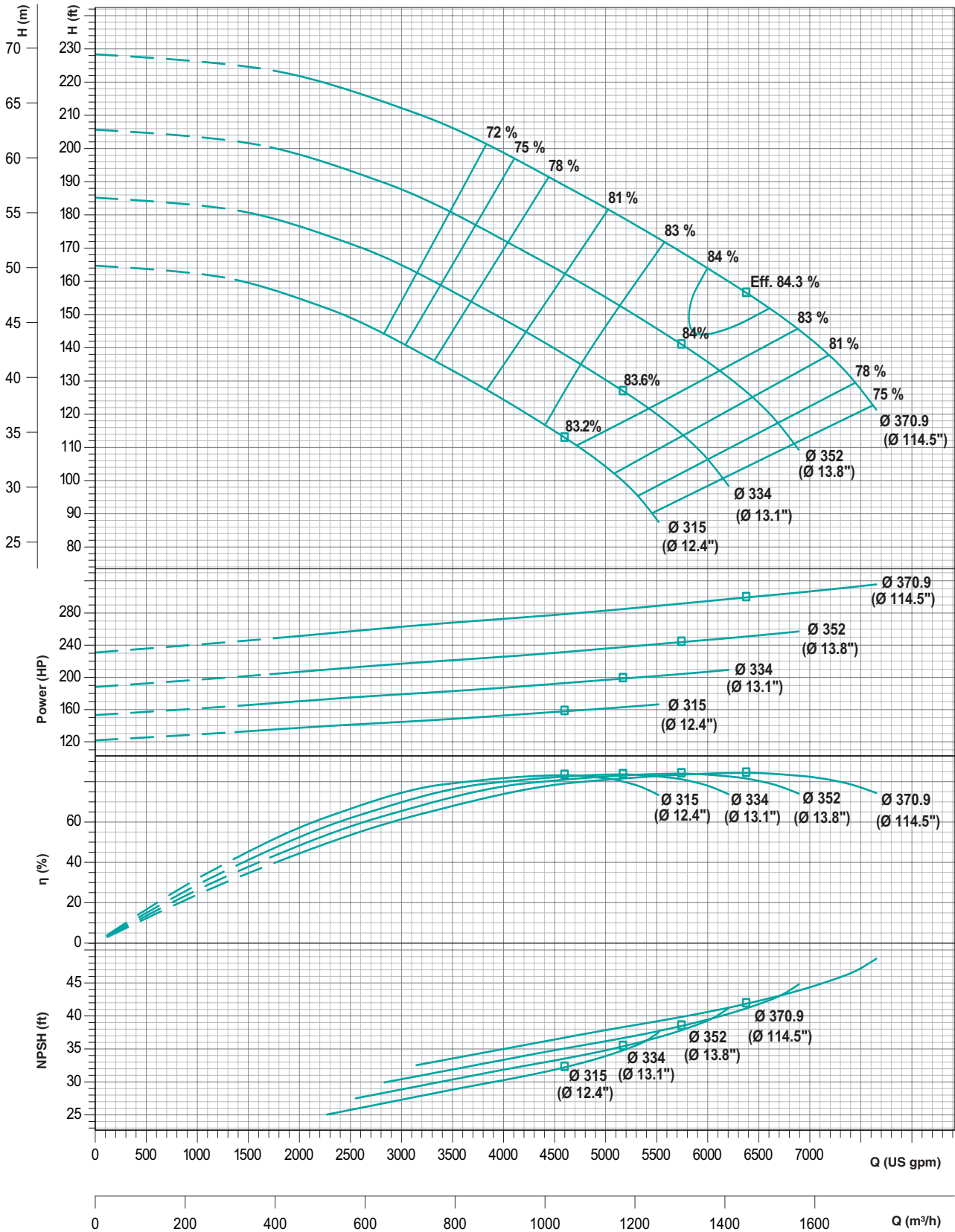

Performance curve tolerances are as per HI : 14.6 / ISO 9906, Grade 2B.
 Note : Performance curve are as per specific gravity and viscosity of water.

PERFORMANCE CURVES

Model : **THSC-300/420**

Speed : **1750 rpm**

Suc x Del (in mm) : **300 x 300**

Max. Impeller Ø : **417mm**

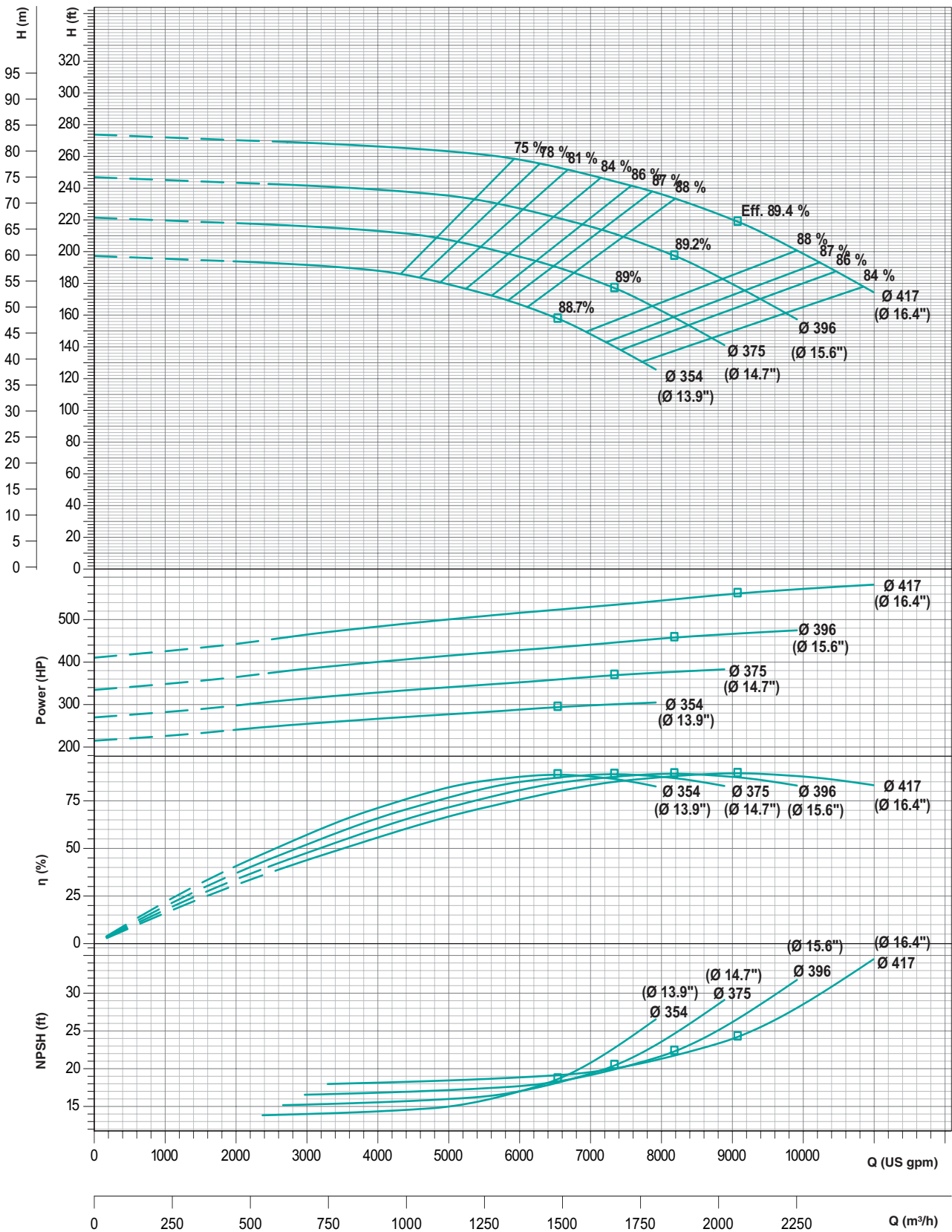

Performance curve tolerances are as per HI : 14.6 / ISO 9906, Grade 2B.
 Note : Performance curve are as per specific gravity and viscosity of water.

PERFORMANCE CURVES

Model : **THSC-400/470**

Speed : **1750 rpm**

Suc x Del (in mm) : **400 x 400**

Max. Impeller Ø : **468.6mm**

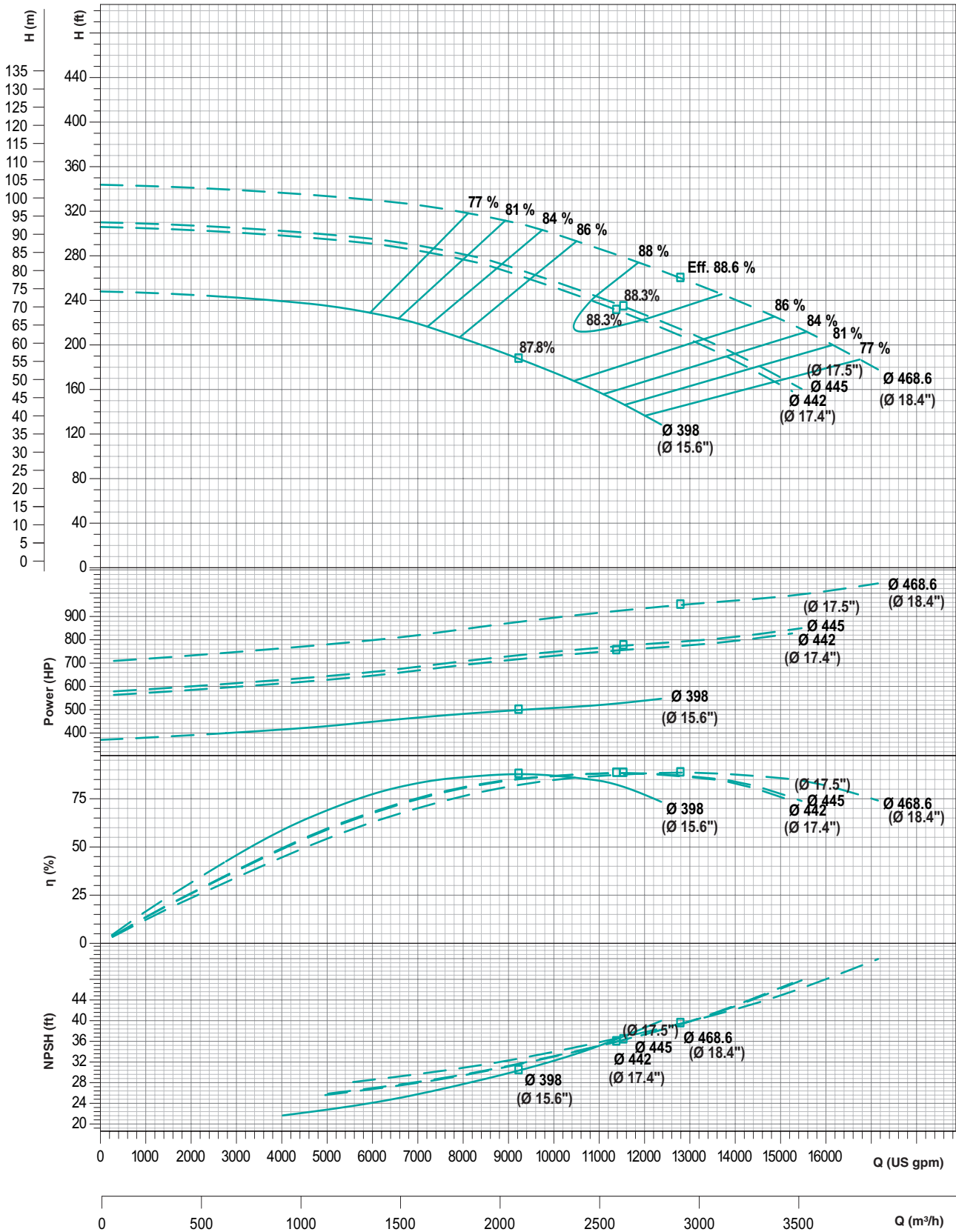

Performance curve tolerances are as per HI : 14.6 / ISO 9906, Grade 2B.
 Note : Performance curve are as per specific gravity and viscosity of water.

PERFORMANCE CURVES

Model : **THSC-450/520**

Speed : **1750 rpm**

Suc x Del (in mm) : **500 x 450**

Max. Impeller Ø : **520mm**

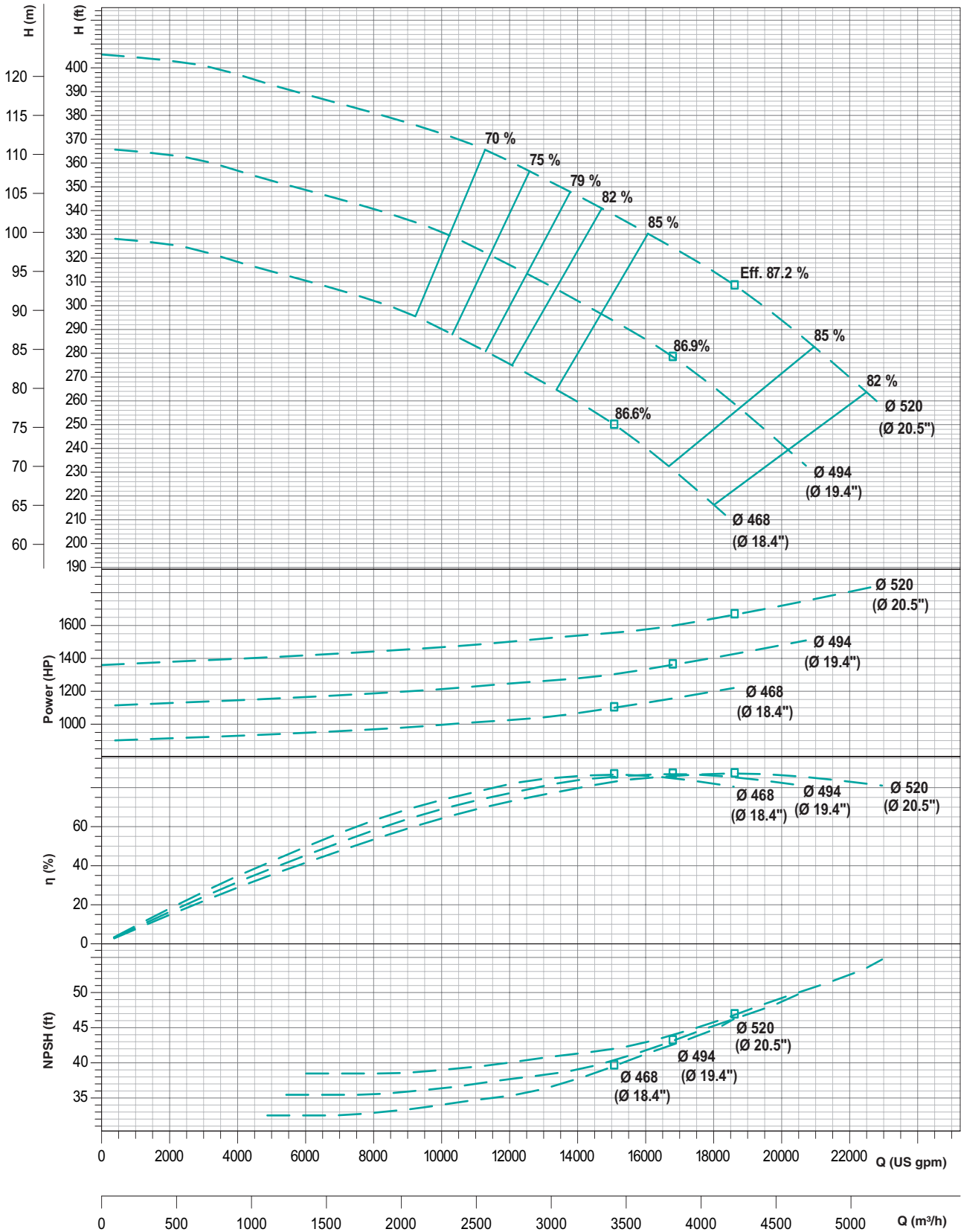

Performance curve tolerances are as per HI : 14.6 / ISO 9906, Grade 2B.
 Note : Performance curve are as per specific gravity and viscosity of water.

PERFORMANCE CURVES

Model : **THSC-350/530**

Speed : **1100 rpm**

Suc x Del (in mm) : **400 x 350**

Max. Impeller Ø : **530mm**

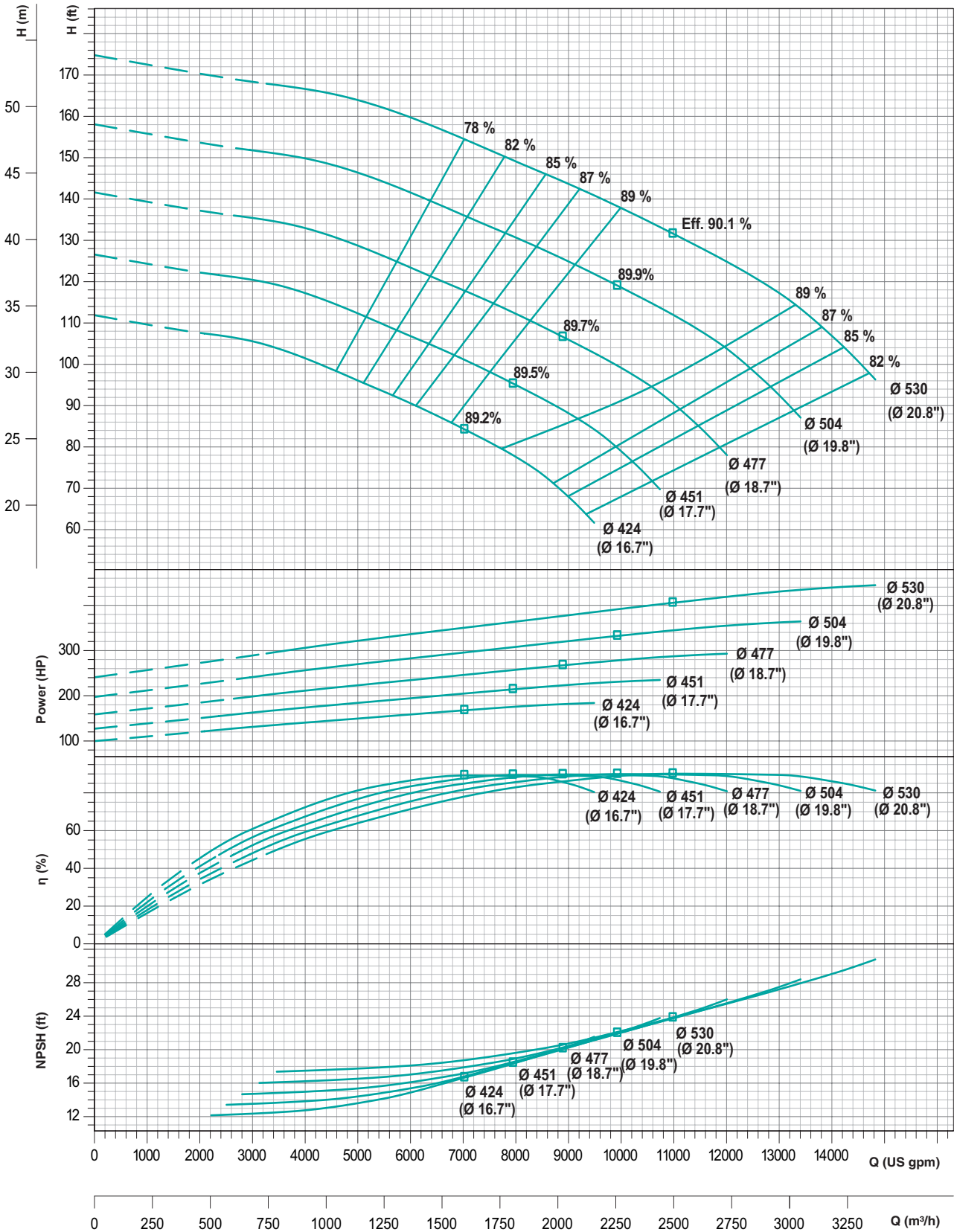

Performance curve tolerances are as per HI : 14.6 / ISO 9906, Grade 2B.
 Note : Performance curve are as per specific gravity and viscosity of water.

PERFORMANCE CURVES

Model : **THSC-100/400**

Speed : **1750 rpm**

Suc x Del (in mm) : **125 x 100**

Max. Impeller Ø : **400mm**

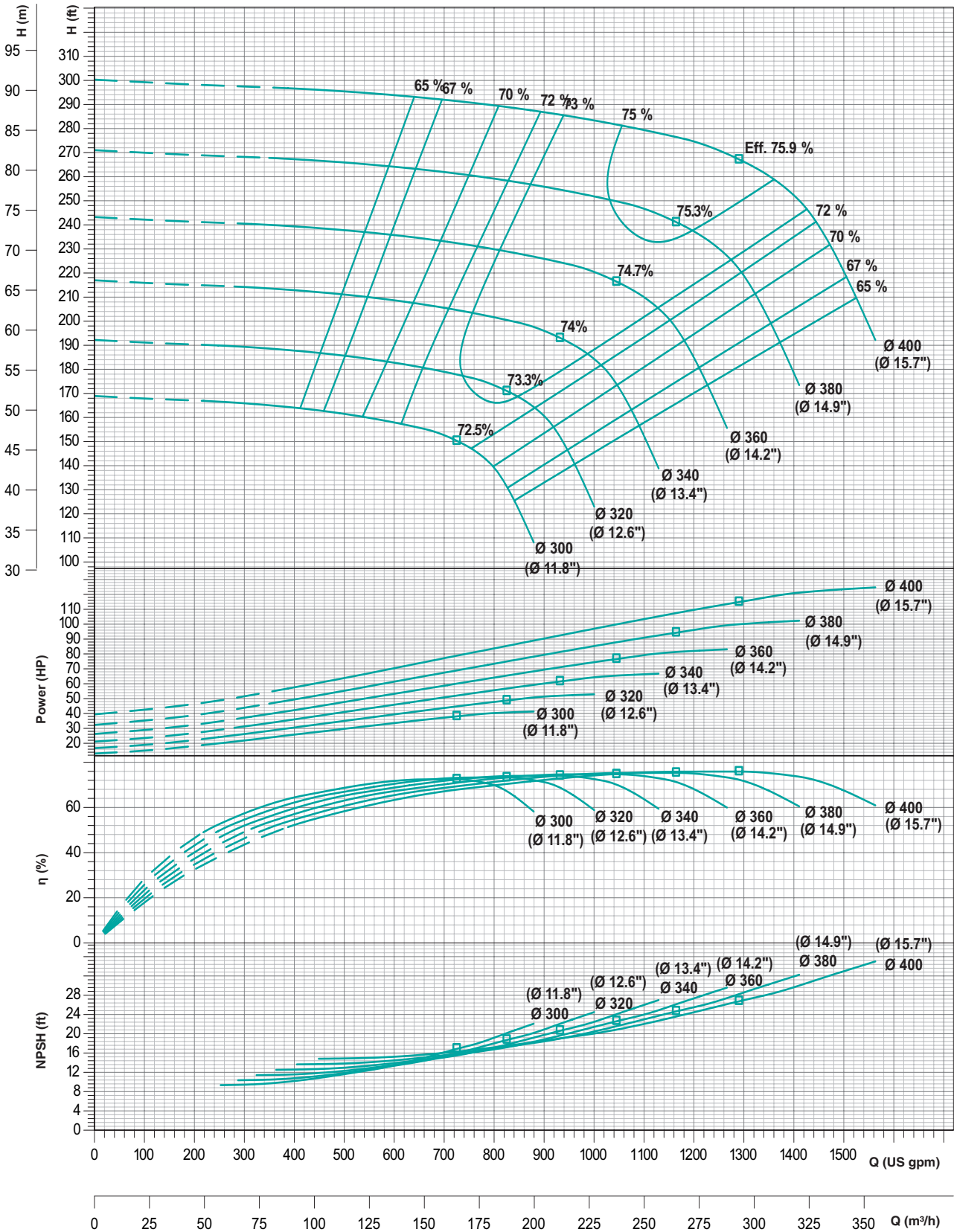

Performance curve tolerances are as per HI : 14.6 / ISO 9906, Grade 2B.
 Note : Performance curve are as per specific gravity and viscosity of water.

PERFORMANCE CURVES

Model : **THSC-150/530**

Speed : **1750 rpm**

Suc x Del (in mm) : **200 x 150**

Max. Impeller Ø : **530mm**

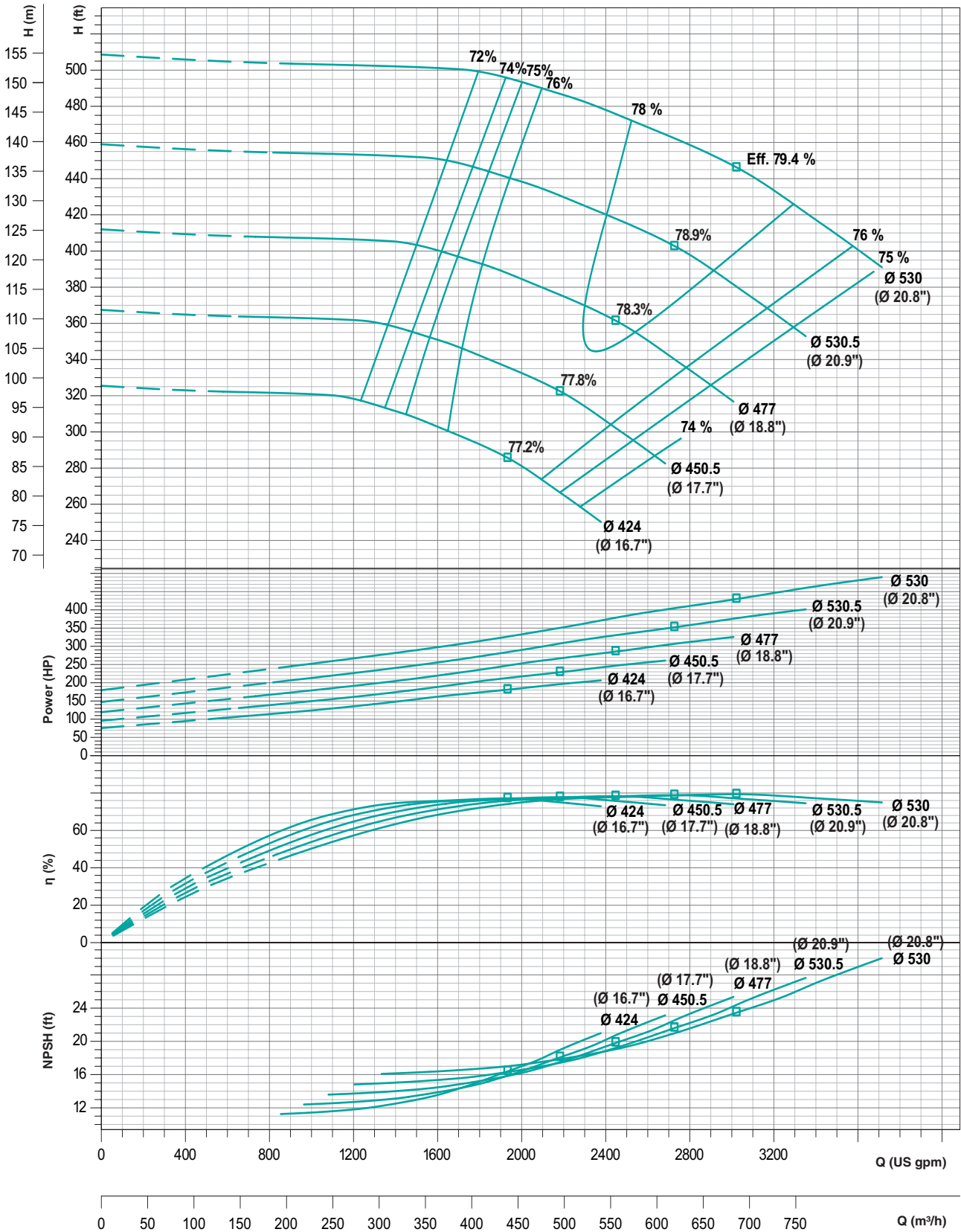

Performance curve tolerances are as per HI : 14.6 / ISO 9906, Grade 2B.
 Note : Performance curve are as per specific gravity and viscosity of water.

PERFORMANCE CURVES

Model : **THSC-80/340**

Speed : **1750 rpm**

Suc x Del (in mm) : **100 x 80**

Max. Impeller Ø : **335mm**

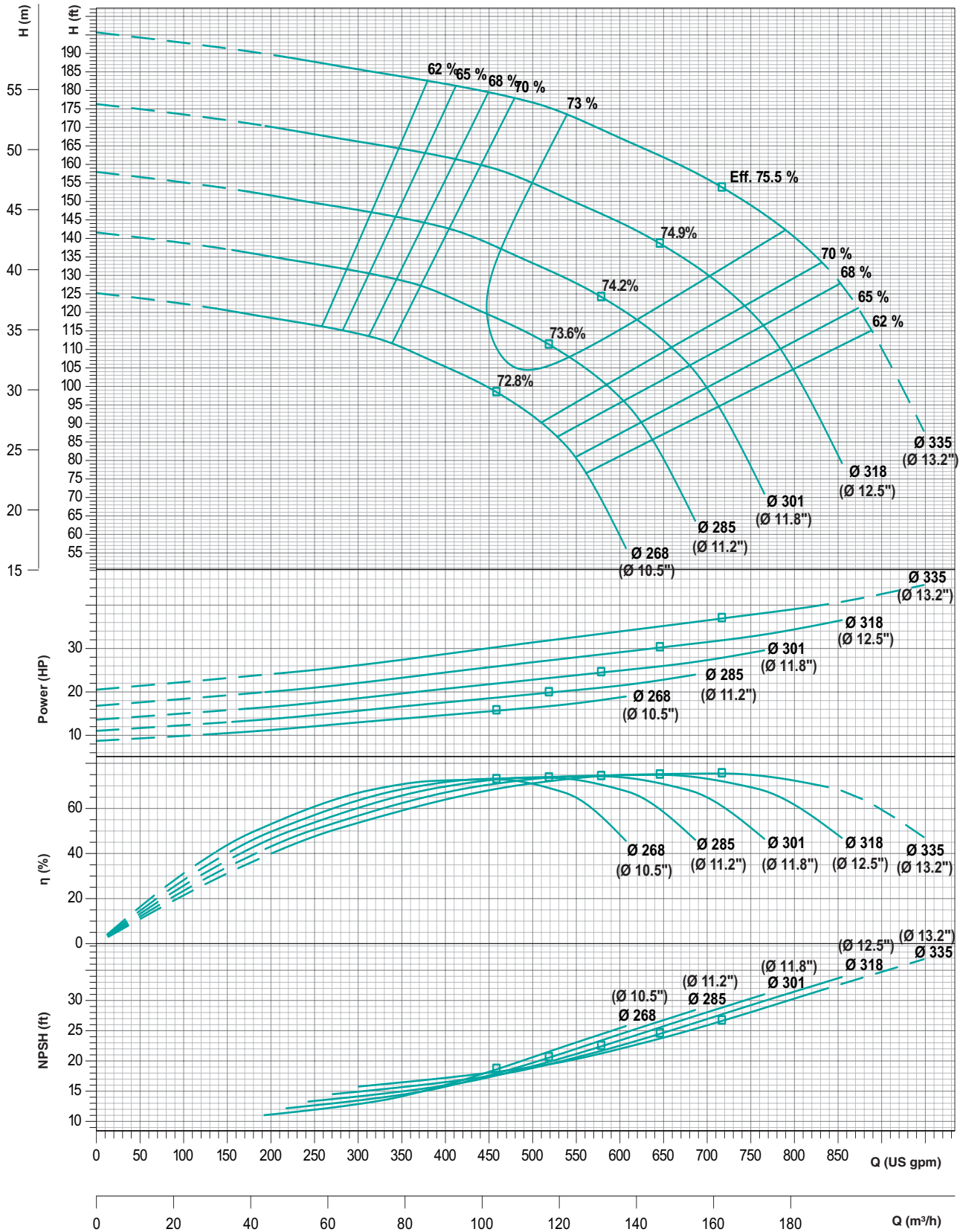

Performance curve tolerances are as per HI : 14.6 / ISO 9906, Grade 2B.

Note : Performance curve are as per specific gravity and viscosity of water.

PERFORMANCE CURVES

Model : **THSC-125/440**

Speed : **1750 rpm**

Suc x Del (in mm) : **150 x 125**

Max. Impeller Ø : **440mm**

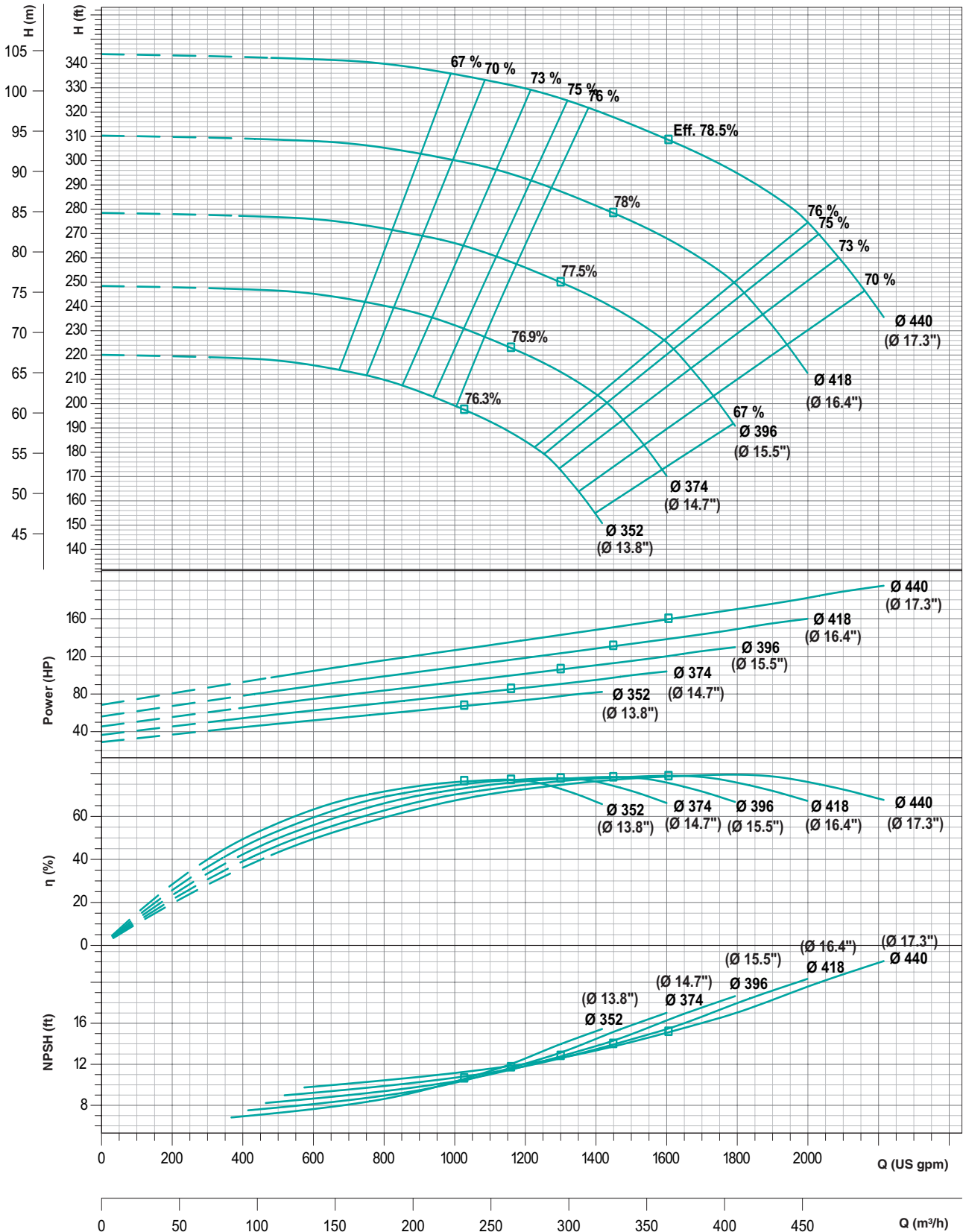

Performance curve tolerances are as per HI : 14.6 / ISO 9906, Grade 2B.
 Note : Performance curve are as per specific gravity and viscosity of water.

PERFORMANCE CURVES

Model : **THSC-125/470**

Speed : **1750 rpm**

Suc x Del (in mm) : **150 x 125**

Max. Impeller Ø : **468mm**

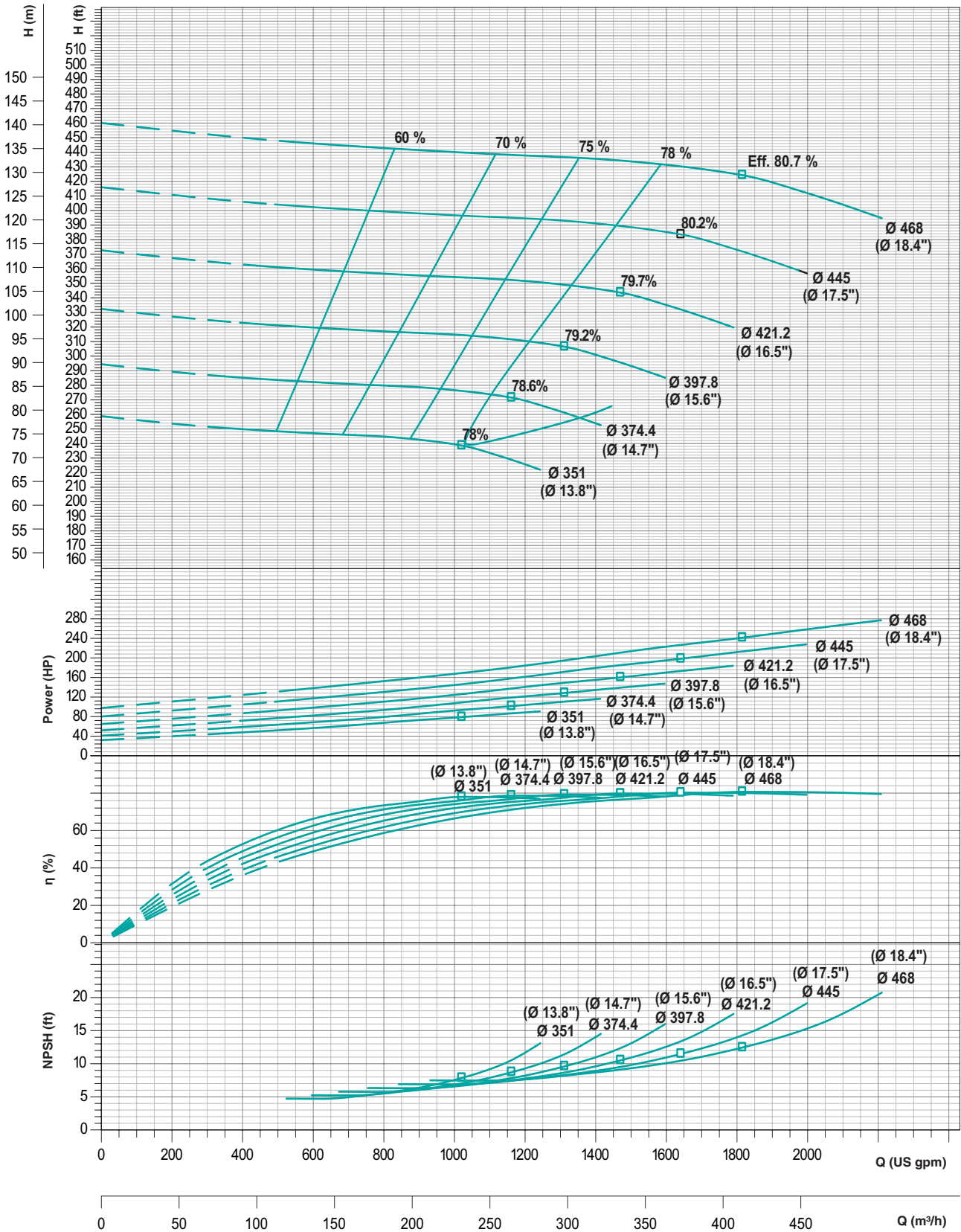









Performance curve tolerances are as per HI : 14.6 / ISO 9906, Grade 2B.
 Note : Performance curve are as per specific gravity and viscosity of water.

INTERCHANGEABILITY CHART

FRAME	MODEL	CASING	IMPELLER	STUFFING BOX	BEARING HOUSING	SHAFT	GLAND	BEARING
								
1	THSC 80/285			THSC 80/285	THSC 80/285	6307		
	THSC 80/340							
	THSC 80/220							
	THSC 100/300			THSC 100/300				
	THSC 100/320							
	THSC 100/250							
2	THSC 100/305			THSC 80/285	THSC 100/305	6309		
	THSC 125/335							
	THSC 100/280							
	THSC 150/300			THSC 80/285				
	THSC 125/400							
	THSC 125/380							
	THSC 125/340							
	THSC 125/440			THSC 125/360				
	THSC 125/470							
	THSC 100/400							
	THSC 125/360							
3	THSC 150/305			THSC 150/305	THSC 150/305	6311		
	THSC 150/450							
	THSC 150/430							
	THSC 150/380							
	THSC 150/320							
	THSC 150/340							
	THSC 150/580							
	THSC 150/530							
	THSC 200/320			THSC 200/430				
	THSC 200/430							
	THSC 200/380			THSC 200/340				
	THSC 200/340							
	THSC 125/300							

Note : According to the charts above, the models can be interchanged seamlessly

INTERCHANGEABILITY CHART

FRAME	MODEL	CASING	IMPELLER	STUFFING BOX	BEARING HOUSING	SHAFT	GLAND	BEARING
								

4	THSC 200/540	THSC 250/330	THSC 250/330	THSC 250/330	THSC 250/330	THSC 250/330	6314	
	THSC 250/400							
	THSC 250/330							
	THSC 250/380							
	THSC 250/425							
	THSC 250/475							
	THSC 200/510							
	THSC 200/460							
	THSC 250/360							
	THSC 250/480							THSC 250/430
	THSC 250/430							
	THSC 300/370							

5	THSC 300/480	THSC 300/420	THSC 300/420	THSC 300/420	THSC 300/420	THSC 300/420	6317	
	THSC 300/600							
	THSC 250/540							
	THSC 200/570							
	THSC 250/590							
	THSC 300/420							
	THSC 300/540							
	THSC 300/450							
	THSC 400/510							
	THSC 400/470							THSC 400/470
	THSC 350/530							

6	THSC 350/560	THSC 450/520	THSC 450/520	6320
	THSC 450/520			
	THSC 400/610	THSC 450/560		
	THSC 450/560			

Note : According to the charts above, the models can be interchanged seamlessly

BARE SHAFT PUMP - MOUNTING DIMENSIONS

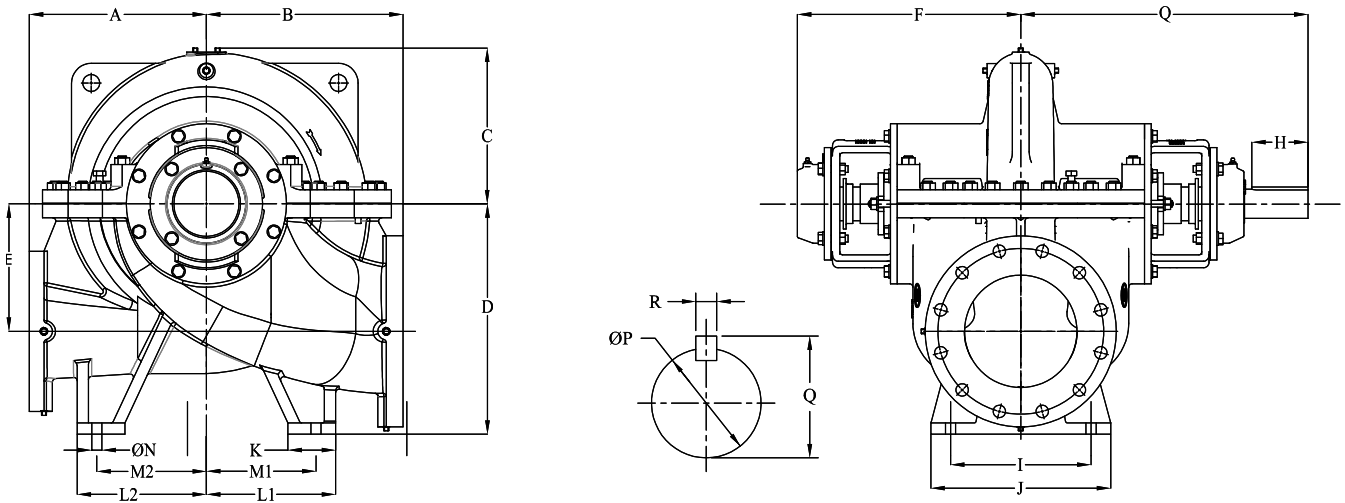

Pump Model	Pump Size (Suc X Del X Imp Ø)	A	B	C	D	E	F	G	H	I	J	K	L1	L2	M1	M2	ØN	ØP	Q	R	WEIGHT kg
THSC 80/285	80X80X285	250	250	220.5	270	167.5	266.5	350	69	180	250	75	175	175	137.5	137.5	18	32.00 31.97	35.00 34.80	10.00 9.96	108.58
THSC 100/300	100X100X300	250	280	248	310	186.7	267	350	69	180	250	75	175	175	137.5	137.5	18	32.00 31.97	35.00 34.80	10.00 9.96	124.05
THSC 100/305	125X100X305	250	280	222	320	179.6	351.3	450	84	190	250	75	175	175	140	140	18	42.00 41.97	45.00 44.80	12.00 11.96	153.11
THSC 150/300	150X150X300	280	320	248	360	200.7	351.3	450	90	250	300	85	200	200	170	170	18	42.00 41.97	45.00 44.80	12.00 11.97	186.11
THSC 150/300	200x150x300	300	350	267	410	215	397.5	511	100	280	350	105	220	220	170	170	18	52.00 51.97	56.00 55.80	16.00 15.96	272.65
THSC 200/320	200X200X320	300	390	322.5	450	258.04	397	511	100	290	360	100	220	220	180	180	18	52.00 51.97	56.00 55.80	16.00 15.96	320.03
THSC 250/330	250X250X330	400	450	358	510	289.4	485	593	95	440	530	120	300	300	260	260	27	65.00 64.97	69.00 68.80	18.00 17.95	499
THSC 100/320	100X100X320	280	280	224.5	310	188.8	267	340	69	190	250	75	175	175	140	140	18	32.00 31.97	35.00 34.80	10.00 9.96	126.48
THSC 125/360	125X125X360	320	320	257	360	211.6	351.3	450	90	240	300	75	225	225	200	200	18	42.00 41.97	45.00 44.80	12.00 11.96	202.37
THSC 125/400	150X125X400	355	355	287	390	238	351.3	450	90	250	320	85	230	230	195	195	18	42.00 41.97	45.00 44.80	12.00 11.96	243.76
THSC 150/450	200X150X450	400	400	340	445	262.3	398	511	100	290	350	100	250	250	212.5	212.5	18	52.00 51.97	56.00 55.80	16.00 15.96	362
THSC 200/510	200X200X510	400	450	383	520	324.15	483.5	593.5	95	360	450	105	300	300	260	260	27	65.00 64.97	69.00 68.80	18.00 17.95	573.63
THSC 200/570	250X200X570	500	500	423	590	350.42	553.5	678.5	100	460	560	150	375	375	310	310	27	80.01 79.99	85.00 84.80	22.00 21.95	888.93
THSC 125/340	125X125X340	280	290	256.6	360	210.4	351.3	450	90	230	300	150	190	190	160	160	18	42.00 41.97	45.00 44.80	12.00 11.96	177.89
THSC 125/380	150X125X380	315	340	287	395	236	352	450	90	250	320	85	230	230	195	195	18	42.00 41.97	45.00 44.80	12.00 11.96	229
THSC 150/430	200X150X430	355	400	340.5	455	265.2	397	511	100	316	380	120	280	280	235	235	18	52.00 51.97	56.00 55.80	16.00 15.96	352.6
THSC 200/460	200X200X460	400	400	353	490	302.2	483.5	593.5	95	370	450	120	300	300	255	255	27	65.00 64.97	69.00 68.80	18.00 17.95	488.75
THSC 200/540	250X200X540	450	500	425	550	325.1	483.5	593.5	95	390	480	120	350	350	305	305	27	65.00 64.97	69.00 68.80	18.00 17.95	692
THSC 250/590	300X250X590	500	500	435	630	373.77	553.5	678.5	100	410	500	150	350	350	290	290	27	80.01 79.99	85.00 84.80	22.00 21.95	949.05
THSC 125/340	150X125X340	280	290	252	360	202	351.3	450	90	250	300	85	200	200	170	170	18	42.00 41.97	45.00 44.80	12.00 11.96	192.3
THSC 150/380	200X150X380	315	350	293	410	227	397.5	511	100	250	320	85	230	230	195	195	18	52.00 51.97	56.00 55.80	16.00 15.96	284.29
THSC 200/430	200X200X430	400	400	312	415	230	397.5	511	100	290	340	100	280	280	235	235	18	52.00 51.97	56.00 55.80	16.00 15.96	352.3
THSC 250/480	250X250X480	470	430	367.5	470	254.5	483.5	593.5	95	400	480	120	300	300	255	255	27	65.00 64.97	69.00 68.80	18.00 17.95	556.99

Note : All Dimensions are in mm, Unless Otherwise Specified

BARE SHAFT PUMP - MOUNTING DIMENSIONS

Pump Model	Pump Size (Suc X Del X Imp Ø)	A	B	C	D	E	F	G	H	I	J	K	L1	L2	M1	M2	ØN	ØP	Q	R	WEIGHT kg
THSC 250/540	300X250X540	450	480	410.6	540	288.0	553.5	678.5	100	410	500	150	350	350	290	290	27	80.01 79.99	85.00 84.80	22.00 21.95	851.22
THSC 300/600	350X300X600	500	600	493	725	440.1	553.5	678.5	100	500	600	150	380	380	325	325	27	80.01 79.99	85.00 84.80	22.00 21.95	1253.54
THSC 150/340	200X150X340	315	365	300	420	235	397.5	511	100	280	350	105	220	220	170	170	18	52.00 51.97	56.00 55.80	16.00 15.96	283.66
THSC 200/380	200X200X380	350	400	334.5	440	254	397	511	100	315	375	100	250	250	210	210	18	52.00 51.97	56.00 55.80	16.00 15.96	350.9
THSC 250/430	250X250X430	450	450	374.5	485	267	483.5	593.5	95	400	480	120	300	300	255	255	27	65.00 64.97	69.00 68.80	18.00 17.95	546.46
THSC 250/480	300X250X480	450	500	417.6	570	320.4	483.5	593.5	95	435	525	120	350	350	305	305	27	65.00 64.97	69.00 68.80	18.00 17.95	683.48
THSC 300/540	350X300X540	500	575	468	650	360.12	554.5	677.5	100	480	600	150	400	400	340	340	27	80.01 79.99	85.00 84.80	22.00 21.95	1026.21
THSC 400/610	400X400X610	570	675	538	800	477.89	662.5	812.5	130	650	800	200	460	460	377	377	27	95.00 94.97	100.0 99.80	25.00 24.95	1954.84
THSC 200/340	200X200X340	335	375	297	425	242	397.5	511	100	300	375	100	220	220	180	180	18	52.00 51.97	56.00 55.80	16.00 15.96	323.1
THSC 250/380	250X250X380	380	425	347	465	244.8	483.5	593.5	95	400	480	120	300	300	255	255	27	65.00 64.97	69.00 68.80	18.00 17.95	742
THSC 250/430	300X250X430	425	500	390.5	540	290.0	483.5	593.5	95	410	500	120	300	300	250	250	27	65.00 64.97	69.00 68.80	18.00 17.95	619.95
THSC 300/480	350X300X480	480	540	434	595	319.22	553.5	678.5	100	480	580	150	375	375	325	325	27	80.01 79.99	85.00 84.80	22.00 21.95	852.81
THSC 350/560	400X350X560	600	650	485	705	385.84	663.5	811.5	130	700	800	200	480	480	410	410	27	95.00 94.97	100.0 99.80	25.00 24.95	1556.3
THSC 250/360	250X250X360	400	450	340	510	290	483.5	593.5	95	390	480	120	300	300	255	255	27	65.00 64.97	69.00 68.80	18.00 17.95	493.87
THSC 250/400	300X250X400	380	475	398	575	326	483.5	593.5	95	390	480	120	300	300	250	250	27	65.00 64.97	69.00 68.80	18.00 17.95	566.3
THSC 300/450	350X300X450	425	525	443	645	366.39	553.5	678.5	100	550	650	150	320	320	260	260	27	80.01 79.99	85.00 84.80	22.00 21.95	865.18
THSC 400/510	400X400X510	600	600	498	720	413.28	553.5	678.5	100	540	650	150	425	425	375	375	27	80.01 79.99	85.00 84.80	22.00 21.95	1149.79
THSC 450/560	500X450X560	625	725	533	855	477.95	663.5	811.5	130	800	920	200	450	450	375	375	27	95.00 94.97	100.0 99.80	25.00 24.95	1954.2
THSC 300/370	300X300X370	450	500	403	565	317.22	483.5	593.5	95	480	570	120	350	350	310	310	27	65.00 64.97	69.00 68.80	18.00 17.95	607.37
THSC 300/420	300X300X420	500	550	443	640	362.56	553.5	678.5	100	540	650	150	400	400	340	340	27	80.01 79.99	85.00 84.80	22.00 21.95	837.01
THSC 400/470	400X400X470	600	625	498	715	407.5	553.5	678.5	100	560	650	150	480	480	425	425	27	80.01 79.99	85.00 84.80	22.00 21.95	1053.11
THSC 450/520	500X450X520	650	750	558	900	505	662.5	812.5	130	760	850	200	480	480	410	410	27	95.00 94.97	100.0 99.80	25.00 24.95	1970.86
THSC 80/220	100X80X220	225	225	179	265	141.2	266.5	350	69	180	230	75	160	160	135	135	18	32.00 31.97	35.00 34.80	10.00 9.96	100
THSC 100/250	125X100X250	220	250	213	305	167.9	266.5	350	69	190	240	100	160	160	125	125	18	32.00 31.97	35.00 34.80	10.00 9.96	113.34
THSC 100/280	125X100X280	250	275	231	325	184.04	350.5	450	90	220	280	100	185	185	150	150	18	42.00 41.97	45.00 44.80	12.00 11.96	161.19
THSC 125/300	150X125X300	300	300	237	350	190.49	397	511	100	310	370	105	205	205	170	170	18	52.00 51.97	56.00 55.80	16.00 15.96	239.01
THSC 150/300	200X150X300	330	350	282	410	227.95	397	511	100	330	400	105	250	250	215	215	18	52.00 51.97	56.00 55.80	16.00 15.96	307.84
THSC 350/530	400X350X530	525	725	543	770.3	450.6	600	725	100	480	600	200	550	350	450	250	27	80.01 79.99	85.00 84.80	22.00 21.95	1187.4

Note : All Dimensions are in mm, Unless Otherwise Specified

NOTES

A series of horizontal dotted lines for writing notes, starting from the 'NOTES' header and extending across the page.

NOTES

A series of horizontal dotted lines for writing notes, starting from the 'NOTES' header and extending across the page.



T H E P O W E R B E H I N D T H E F O R C E

Naargo Industries Private Limited, one of the leading manufacturers of latest state of art, large range of pumps and motors, is managed by veterans who are in the pump industry for almost half a century. The products are employed in various applications like irrigation, domestic, civil construction, de-watering etc; The Company has a strong distribution network in India for sales & service and a strong global presence.

Quality is the key factor in Naargo's products. The expansive infrastructure and environment accredited with ISO 9001 quality certification, latest engineering softwares, high-tech machinery, futuristic pumping technology and high caliber workforce facilitate the production of flawless and efficient products on par with international standards under the brand name of "Tormac". The well equipped R & D wing stays alive to the changing global trends and comes out with viable solutions for innovative product development and upgradation.

The Products currently available include Stainless Steel Submersible Pumps (SS 304, SS 316 & SS 904L), Submersible Motors (CI, SS 304, SS 316 & SS 904L - HT on optional), Starters & Control Panels, Centrifugal Monoblock Pumps, End Suction Pumps, Close Coupled Pumps, Horizontal Split Case Pumps, Horizontal & Vertical Multistage Pumps, Inline Booster Systems, Sewage, Drainage & Dewatering Pumps, Induction Motors, Submersible Cables, Riser Pipes and Column Pipes.

The power, performance and endurance of the products backed by the uncompromising teamwork and value systems will certainly propel the company's growth towards new horizons in the pump industry.

Naargo Industries Private Limited,

REG. OFFICE : No. 8/116, Ground Floor, Athipalayam Road, Chinnavedampatti,
Coimbatore North - 641049, Tamil Nadu, India. Tel : +91 978 6522622,
E-mail : tormac@tormacpumps.com, Web : www.tormacpumps.com