



BREAK THROUGH TECHNOLOGY THAT BREAKS ALL BARRIERS



Product from an ISO 9001 COMPANY

**END SUCTION
CENTRIFUGAL PUMPS - 60Hz**

C O N T E N T S

END SUCTION CENTRIFUGAL PUMPS - TEH Series (60Hz)

	Page No.
Model Identification Code & Materials of Construction	4-5
General Pump Selection & Operation Instructions	5
Description, Key Features, Applications & Technical Specifications	6
Cross Sectional Drawing	7
Performance Curves	8 - 83
Stuffing Box Details	84
Interchangeability Chart	85
Bare Shaft Pump - Mounting Dimensions (Standard Design)	86 - 87
Bare Shaft Pump - Mounting Dimensions (Pedestal Design)	88-89

Model Classification END SUCTION CENTRIFUGAL PUMPS

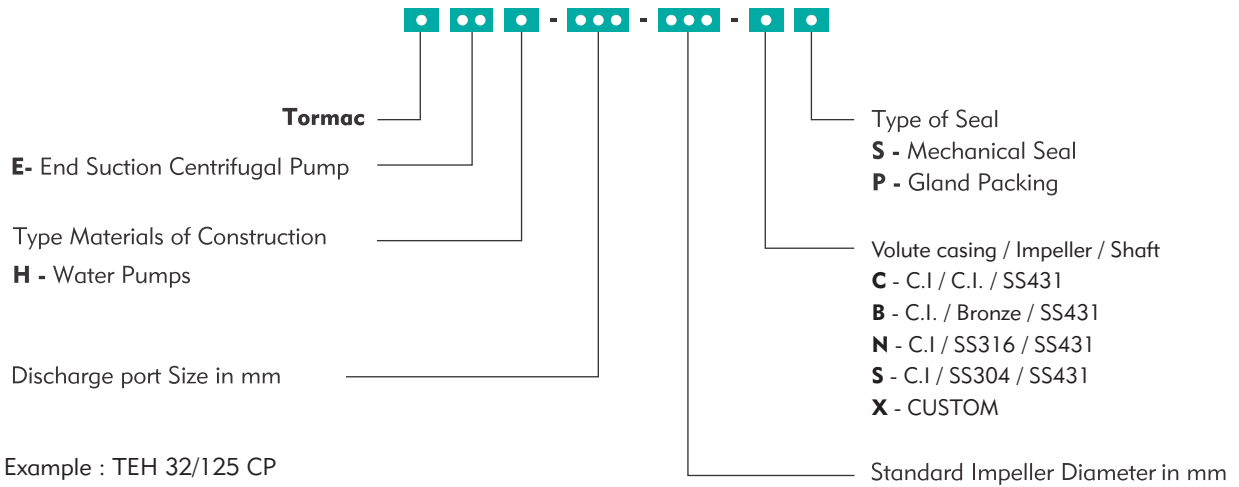

MATERIAL OF CONSTRUCTION

TYPE C

Parts Name	Material	EUROPEAN	DIN	SAE/AISI
Casing	Cast Iron	EN-GJL-250	(0.6025) GG25	ASTM A48 class 40
Impeller	Cast Iron	EN-GJL-220	(0.6020) GG20	ASTM A48 class 30B
Stuffing Box	Cast Iron	EN-GJL-250	(0.6025) GG25	ASTM A48 class 40
Wear Ring	Cast Iron	EN-GJL-220	(0.6020) GG20	ASTM A48 class 30B
Bearing Frame	Cast Iron	EN-GJL-220	(0.6020) GG20	ASTM A48 class 30B
Shaft	SS 431	X17CrNi16-2	1.4057	ASTM A276 AISI 431
Shaft Sleeve	SS 410	X12Cr13	1.4006	ASTM A276 AISI 410

TYPE B

Parts Name	Material	EUROPEAN	DIN	SAE/AISI
Casing	Cast Iron	EN-GJL-250	(0.6025) GG25	ASTM A48 class 40
Impeller	Bronze LTB2	G-CuPb15Sn	DIN 1716-1981	ASTM B505 C93800
Stuffing Box	Cast Iron	EN-GJL-250	(0.6025) GG25	ASTM A48 class 40
Wear Ring	LTB4	G-CuPb15Sn	DIN 1716-1981	ASTM B505 C93800
Bearing Frame	Cast Iron	EN-GJL-220	(0.6020) GG20	ASTM A48 class 30B
Shaft	S.S 431	X17CrNi16-2	1.4057	ASTM A276 AISI 431
Shaft Sleeve	S.S 410	X12Cr13	1.4006	ASTM A276 AISI 410

TYPE S

Parts Name	Material	EUROPEAN	DIN	SAE/AISI
Casing	Cast Iron	EN-GJL-250	(0.6025) GG25	ASTM A48 CLASS 40
Impeller	CF8 (SS 304)	X5CrNi18-9	1.4308	ASTM A743 / A351 CF8
Stuffing Box	Cast Iron	EN-GJL-250	90.6025) GG25	ASTM A48 CLASS 40
Wear Ring	Bronze (LTB4)	G-CuPb15Sn	DIN 1716-1981	ASTM B505 C93800
Bearing Frame	Cast Iron	EN-GJL-220	(0.6020) GG20	ASTM A48 class 30B
Shaft	S.S 431	X5CrNi18-10	1.4057	ASTM A276 AISI 431
Shaft Sleeve	S.S 304	X17Cr Ni 16-2	1.4301	ASTM A276 AISI 304

TYPE N

Parts Name	Material	EUROPEAN	DIN	SAE/AISI
Casing	Cast Iron	EN-GJL-250	(0.6025) GG25	ASTM A48 CLASS 40
Impeller	CF8M (SS316)	X6CrNiMo 18 10	1.4408	ASTM A743 / A351 CF8M
Stuffing Box	Cast Iron	EN-GJL-250	90.6025) GG25	ASTM A48 CLASS 40
Wear Ring	Bronze (LTB4)	G-CuPb15Sn	DIN 1716-1981	ASTM B505 C93800
Bearing Frame	Cast Iron	EN-GJL-220	(0.6020) GG20	ASTM A48 class 30B
Shaft	S.S 431	X17Cr Ni 16-2	1.4057	ASTM A276 AISI 431
Shaft Sleeve	S.S 316	X5CrNiMo 18 10	1.4401	ASTM A276 AISI 316

The Company reserves the right to modify the technical specifications and illustrations without prior notice.

GENERAL PUMP SELECTION & OPERATION INSTRUCTIONS

1. All performance curves are based on water (specific gravity = 1.0; low viscosity). Corrections must be applied for fluids with different properties.
2. Select a motor or engine with sufficient power margin above the pump duty point. This prevents overloading under normal and transient operating conditions.
3. Always calculate NPSHA (Net Positive Suction Head Available) carefully, especially when pumping hot or cold liquids with negative or positive suction. Account for vapor pressure effects.
4. Ensure $NPSHA \geq NPSHR + 0.5m$ to avoid cavitation during both negative and positive suction conditions.
5. For high-viscosity fluids, apply viscosity correction factors to head, flow and efficiency.
6. Choose pumps to operate within 70% to 120% of the Best Efficiency Point (BEP) against flow. Operating within this range ensures better efficiency, reliability, and reduced wear.
7. Select pump materials based on fluid properties:
 - i. Chemical compatibility
 - ii. Operating temperature
 - iii. Abrasiveness or corrosiveness
8. Use suction and discharge piping at least one nominal size larger than the pump nozzle to reduce friction losses and turbulence.
9. Delivery Side:
 - i. Install a Non-Return Valve (NRV) to prevent backflow.
 - ii. Install a gate or globe valve to control flow during start-up/shutdown.
10. Start-Up and Shut-Down Procedure:
 - i. Keep the delivery valve closed when starting or stopping the pump.
 - ii. For mixed flow pumps and pumps with a rising power curve toward shut-off, the pump must be started and stopped with the delivery valve in the open position, or as per the manufacturer's specific recommendations.
11. All pump performance curve tolerances conform to HI : 14.6 / ISO : 9906 Grade 2B standards.

GENERAL DATA

END SUCTION CENTRIFUGAL PUMPS > TEH SERIES

Construction

The TEH series pumps are designed to meet the rigorous demands of fluid handling systems, offering both versatility and reliability across a range of applications. They are single-stage, end-suction, back pull-out pumps with a top centerline discharge, adhering to the EN733/ DIN24255/ ISO 9906 STANDARD standards. Optimised hydraulic design is engineered to achieve higher efficiency, reducing energy consumption and operating costs. Dynamically balanced impeller ensures smooth, vibration-free operation, leading to extended service life and reduced noise. Back pull-out design allows for quick and easy maintenance without disrupting the pipe connections, minimizing downtime. Available in both gland-packed and mechanically sealed configurations, offering options for different operational environments.



TECHNICAL SPECIFICATIONS

Head Range	490 ft
Flow Range	3150 gpm
Speed	1750 / 3500 rpm
Impeller Type	Closed Impeller
Outlet Size	1" - 6"
Power Range	0.75 - 200 HP
Maximum Liquid Temperature	14°F - 194°F
Shaft Seal	Standard : Gland Packing Optional : Mechanical seal
Bearing Lubrication	Pre-lubricated sealed bearing
Flange Standard	ANSI / DIN
Maximum working Pressure	12 - 16 bar

Applications

Water supply
Pressure boosting
Heating, ventilation and air conditioning system
Firefighting systems
Hot and cold water circulation
Cooling Tower
Solvent transfer
Clean juice in sugar plant
Agriculture & Irrigation

Features

Optimized hydraulic Design
Low NPSHr
Wide hydraulic ranges
Modular design to minimize the spare parts inventory
Oversized bearing design for extended life
Different material options

CROSS SECTIONAL DRAWING

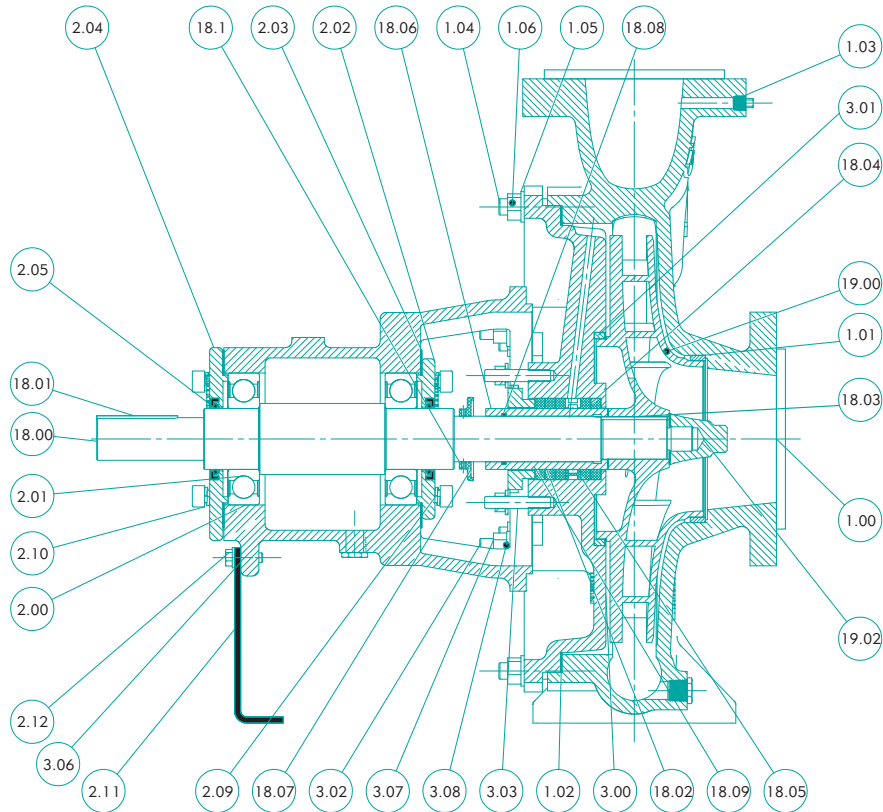

PART NO	PART NAME
1.00	Casing
1.01	Front Wearing Ring
1.02	Gasket - Casing
1.03	Square Plug
1.04	Stud M16*
1.05	Flat Washer M16*
1.06	Hex Nut - M16 x 2*
2.00	Bearing Housing
2.01	Deep Groove Ball Bearing
2.02	Front Cover
2.03	Gasket - Rear Cover
2.04	Rear Cover
2.05	Oil Seal
2.09	Lock Washer
2.10	Socket Head Bolt
2.11	Support Foot
2.12	Hex. Bolt M10*
3.00	Stuffing Box
3.01	Rear Wear Ring

PART NO	PART NAME
3.02	Stud M16*
3.03	Stud M12*
3.04	Flat Washer M12*
3.05	Hex Nut - M12 x 1.75*
3.06	Flat Washer M10*
3.07	Nut M16*
3.08	Washer M16*
18.00	Shaft
18.01	Key - Coupling
18.02	Shaft Sleeve
18.03	Key - Impeller
18.04	Gland Packing
18.05	Lantern Ring
18.06	Split Gland
18.07	Deflector
18.08	O-Ring
18.09	Gasket - Sleeve
18.10	Grub Screw
19.00	Impeller
19.02	Impeller Nut

* Size can be varying based on frame size.

The Company reserves the right to modify the technical specifications and illustrations without prior notice.

PERFORMANCE CURVES

Model : **TEH-25-160**

Speed : **1750 rpm**

Suc x Del (in mm) : **40 x 25**

Max. Impeller Ø : **169mm**

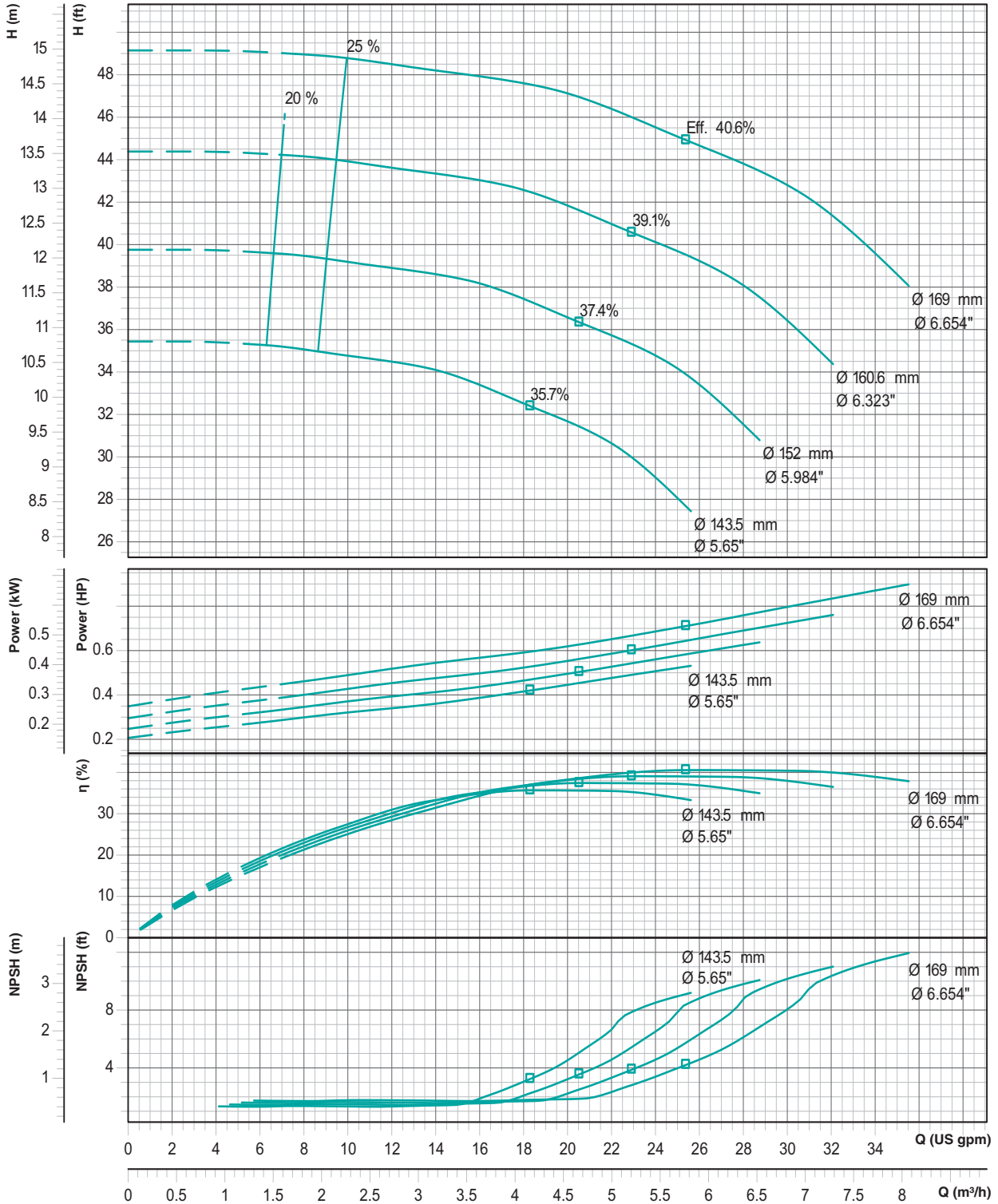

Performance curve tolerances are as per HI : 14.6 / ISO: 9906, Grade 2B

The Company reserves the right to modify the technical specifications and illustrations without prior notice.

PERFORMANCE CURVES

Model : **TEH-25-160**

Speed : **3500 rpm**

Suc x Del (in mm) : **40 x 25**

Max. Impeller Ø : **169mm**

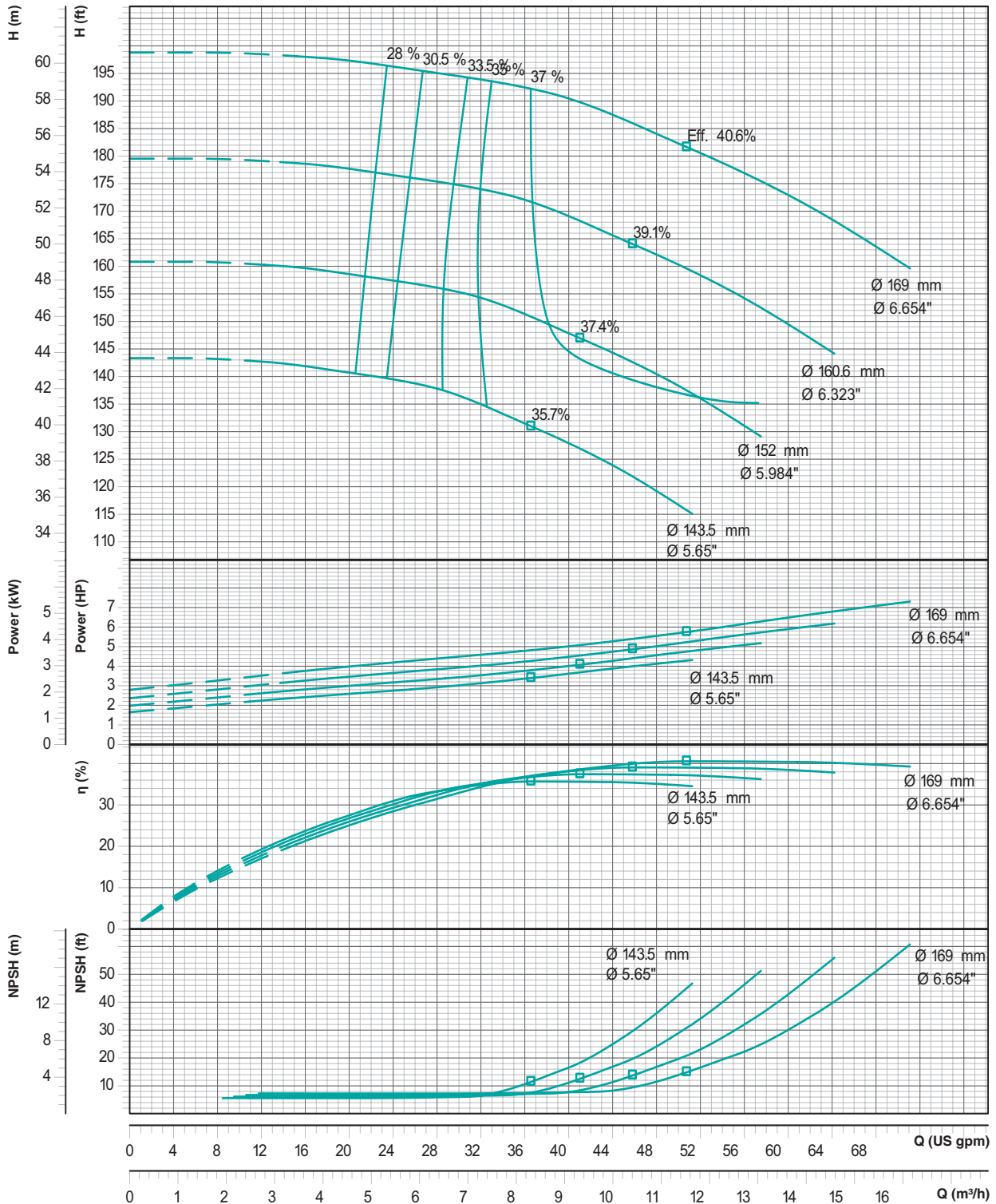

Performance curve tolerances are as per HI : 14.6 / ISO: 9906, Grade 2B

The Company reserves the right to modify the technical specifications and illustrations without prior notice.

PERFORMANCE CURVES

Model : **TEH-25-200**

Speed : **1750 rpm**

Suc x Del (in mm) : **40 x 25**

Max. Impeller Ø : **209mm**

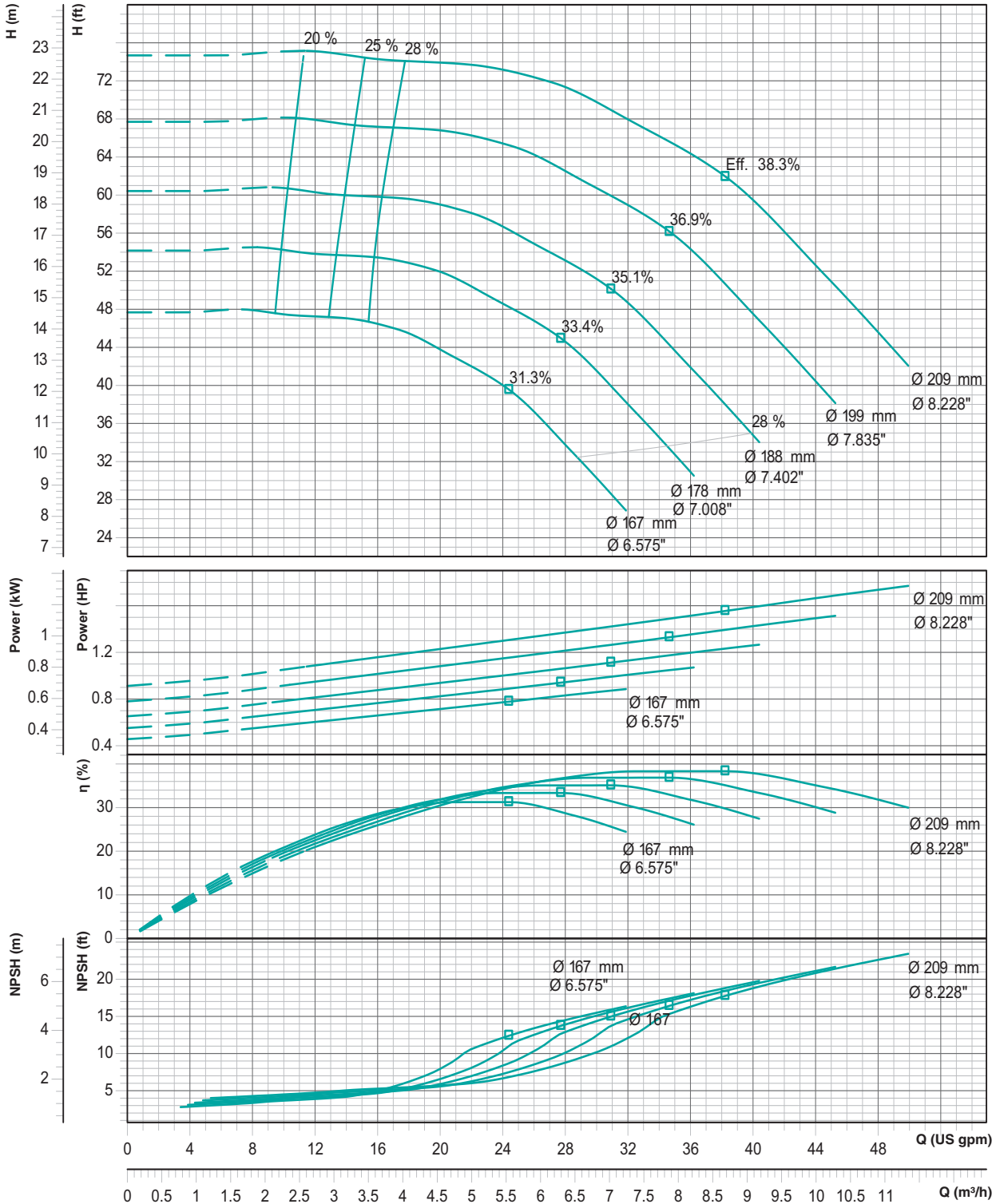

Performance curve tolerances are as per HI : 14.6 / ISO: 9906, Grade 2B

The Company reserves the right to modify the technical specifications and illustrations without prior notice.

PERFORMANCE CURVES

Model : **TEH-25-200**

Speed : **3500 rpm**

Suc x Del (in mm) : **40 x 25**

Max. Impeller Ø : **209mm**

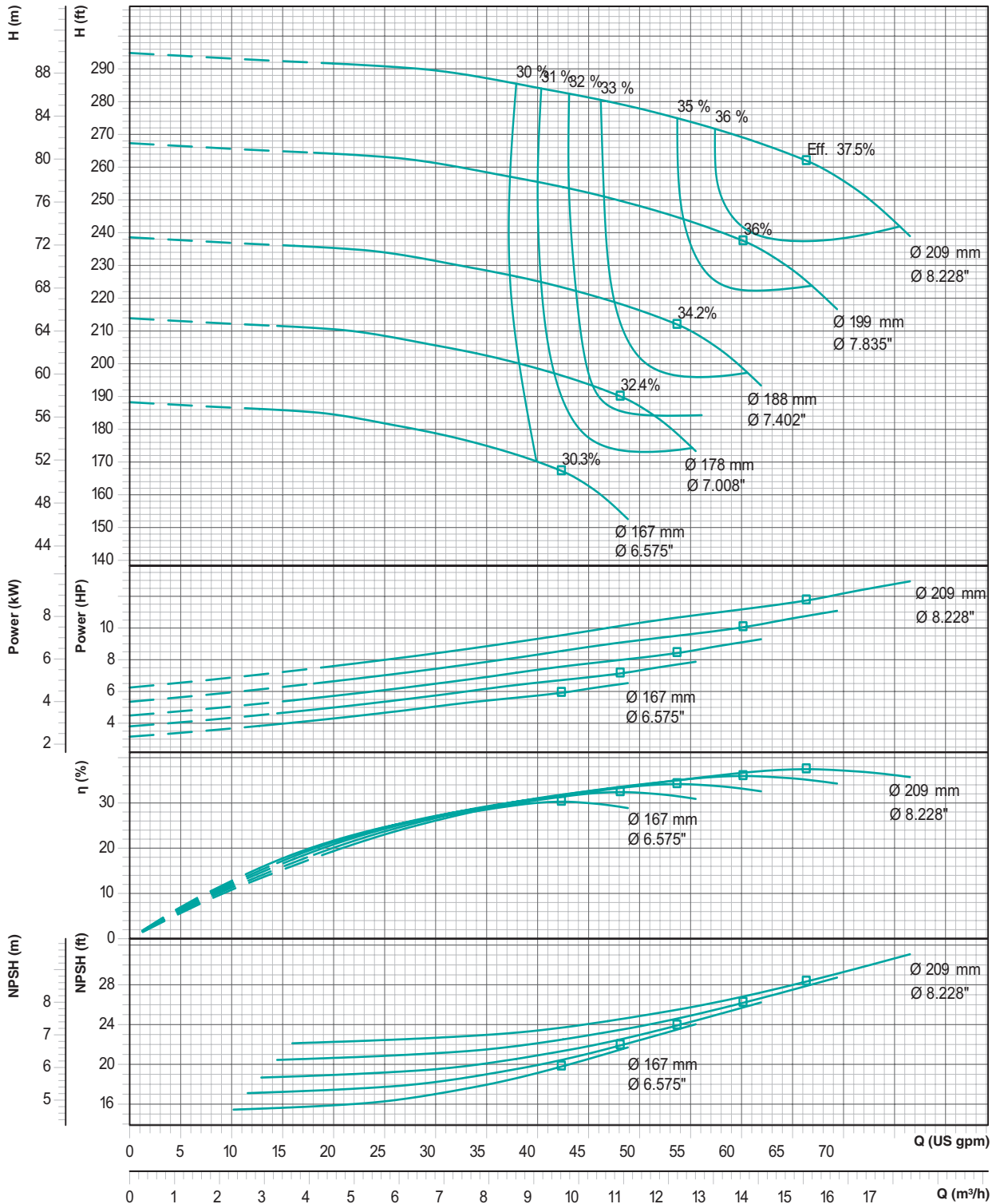

Performance curve tolerances are as per HI : 14.6 / ISO: 9906, Grade 2B

The Company reserves the right to modify the technical specifications and illustrations without prior notice.

PERFORMANCE CURVES

Model : **TEH-32-125**

Speed : **1750 rpm**

Suc x Del (in mm) : **50 x 32**

Max. Impeller Ø : **139mm**

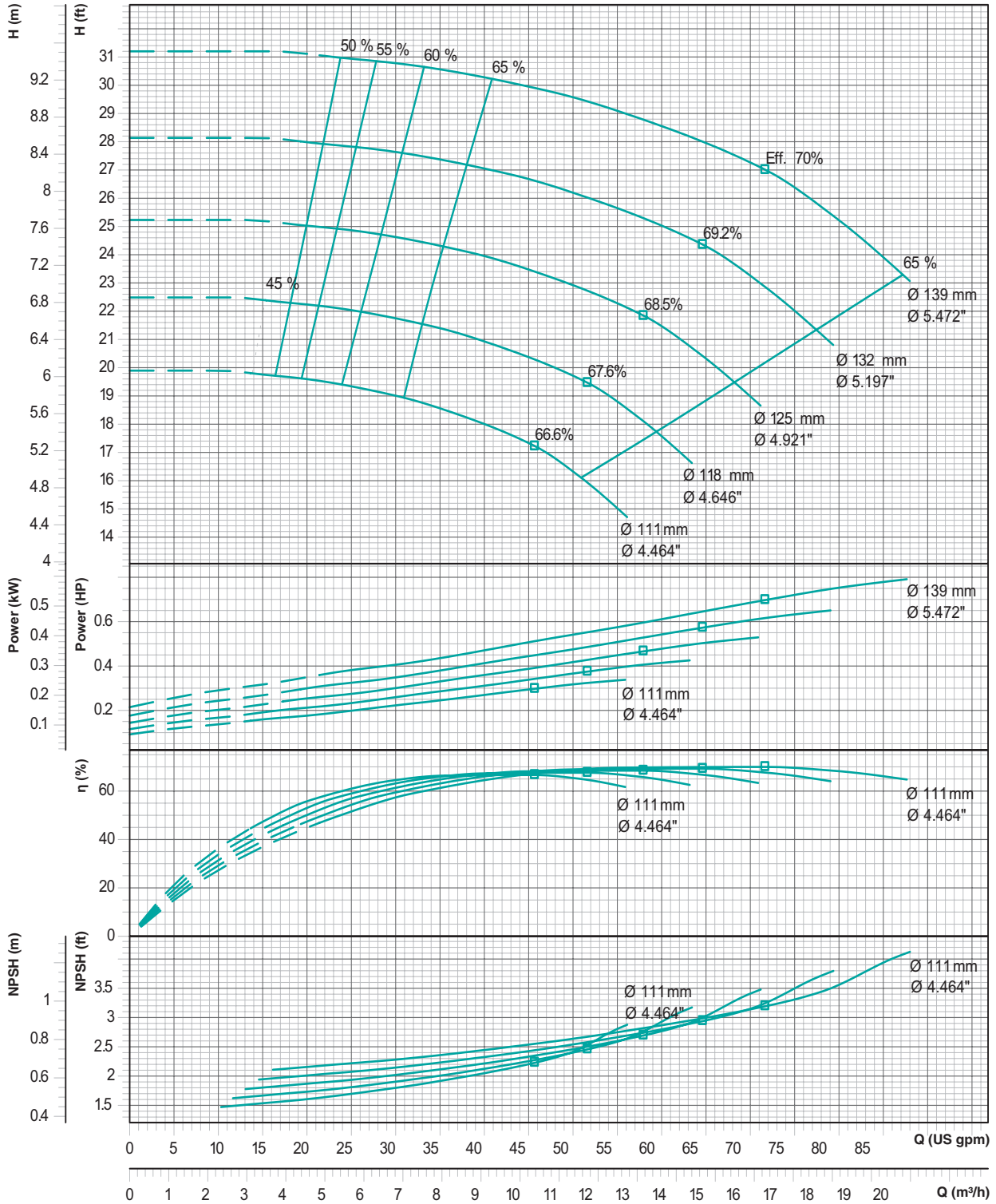

Performance curve tolerances are as per HI : 14.6 / ISO: 9906, Grade 2B

The Company reserves the right to modify the technical specifications and illustrations without prior notice.

PERFORMANCE CURVES

Model : **TEH-32-125**

Speed : **3500 rpm**

Suc x Del (in mm) : **50 x 32**

Max. Impeller Ø : **139mm**

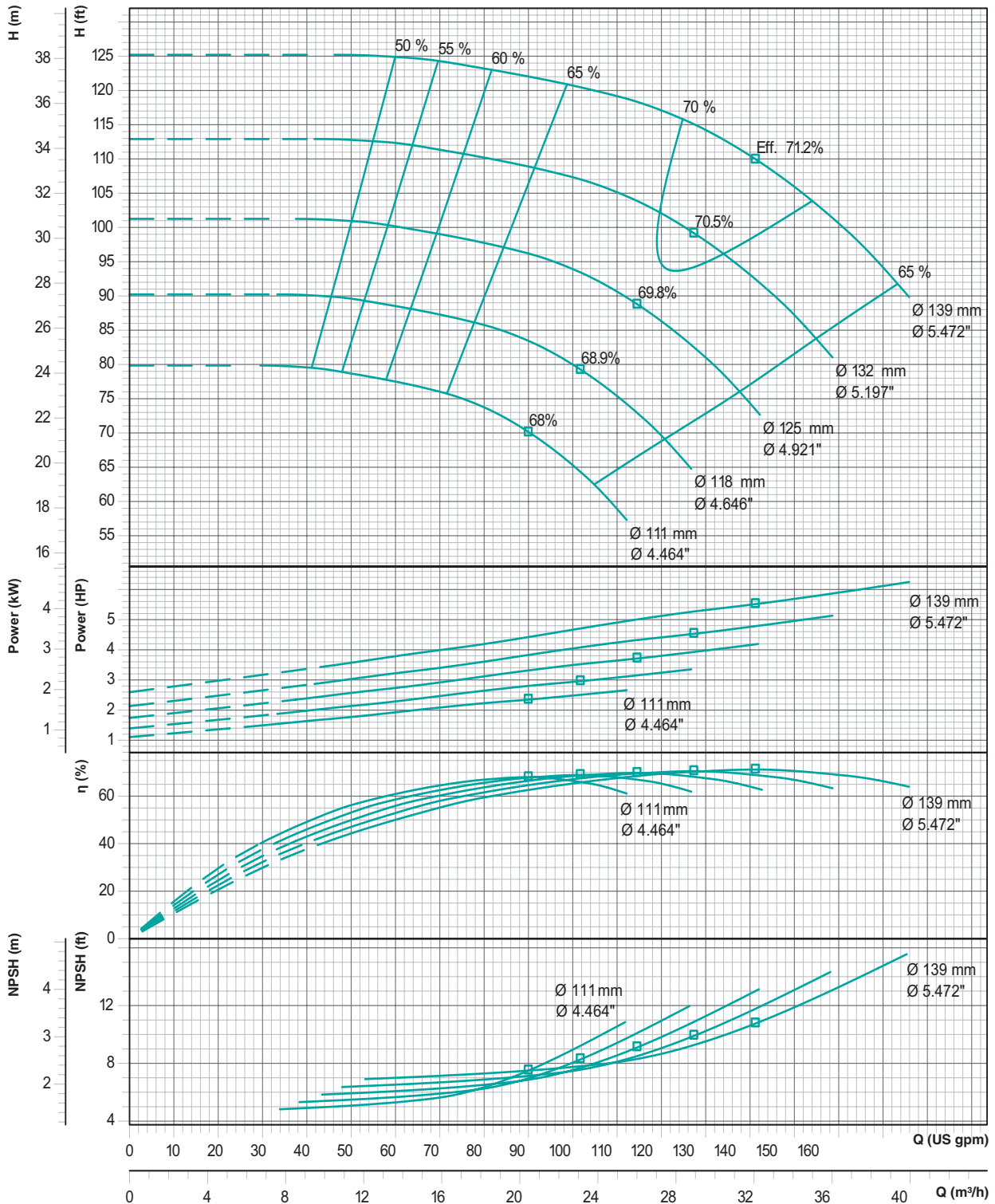

Performance curve tolerances are as per HI : 14.6 / ISO: 9906, Grade 2B

The Company reserves the right to modify the technical specifications and illustrations without prior notice.

PERFORMANCE CURVES

Model : **TEH-32-125E**

Speed : **1750 rpm**

Suc x Del (in mm) : **50 x 32**

Max. Impeller Ø : **139mm**

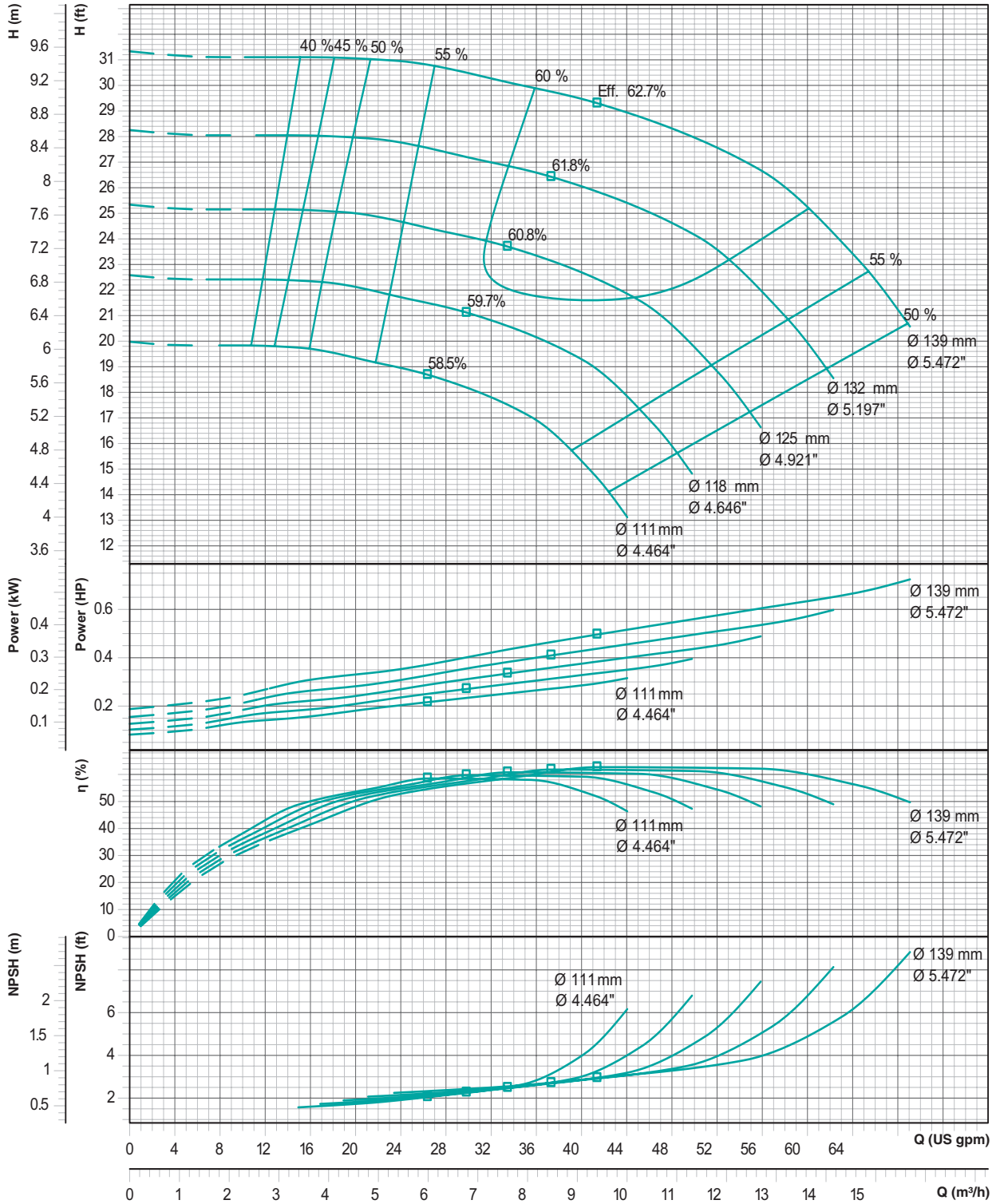

Performance curve tolerances are as per HI : 14.6 / ISO: 9906, Grade 2B

The Company reserves the right to modify the technical specifications and illustrations without prior notice.

PERFORMANCE CURVES

Model : **TEH-32-125E**

Speed : **3500 rpm**

Suc x Del (in mm) : **50 x 32**

Max. Impeller Ø : **139mm**

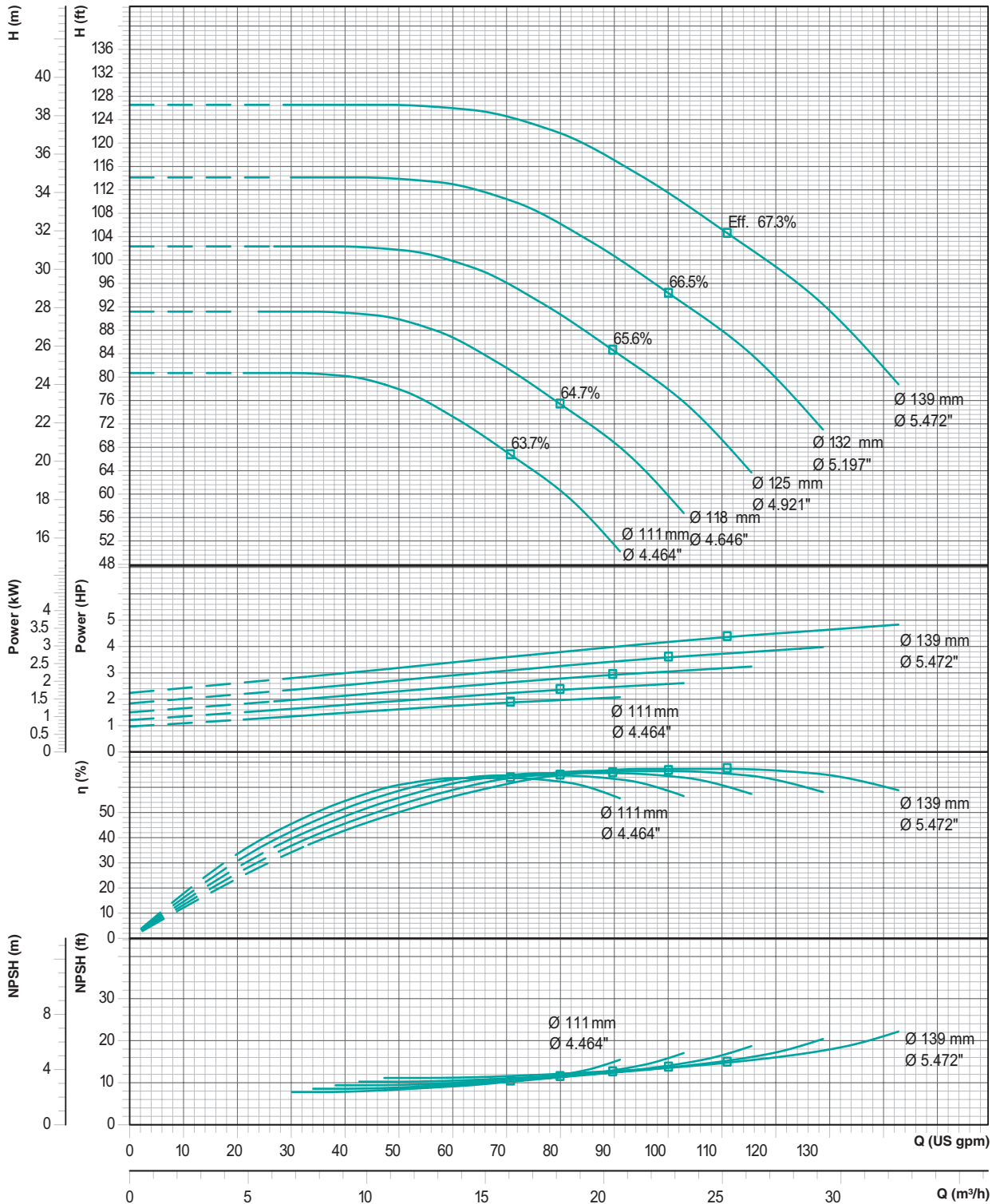

Performance curve tolerances are as per HI : 14.6 / ISO: 9906, Grade 2B

The Company reserves the right to modify the technical specifications and illustrations without prior notice.

PERFORMANCE CURVES

Model : **TEH-32-160**

Speed : **1750 rpm**

Suc x Del (in mm) : **50 x 32**

Max. Impeller Ø : **170mm**

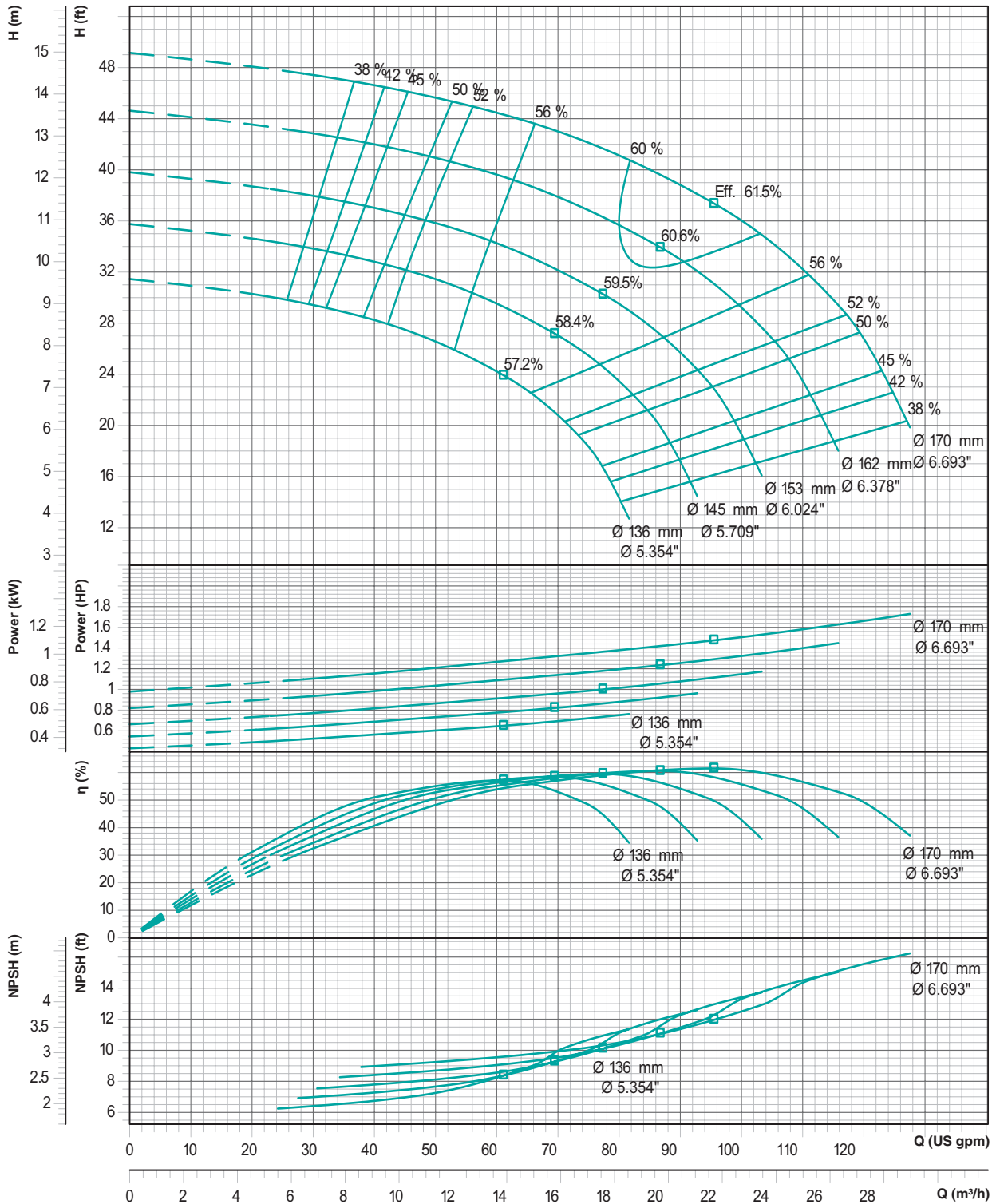

Performance curve tolerances are as per HI : 14.6 / ISO: 9906, Grade 2B

The Company reserves the right to modify the technical specifications and illustrations without prior notice.

PERFORMANCE CURVES

Model : **TEH-32-160**

Speed : **3500 rpm**

Suc x Del (in mm) : **50 x 32**

Max. Impeller Ø : **170mm**

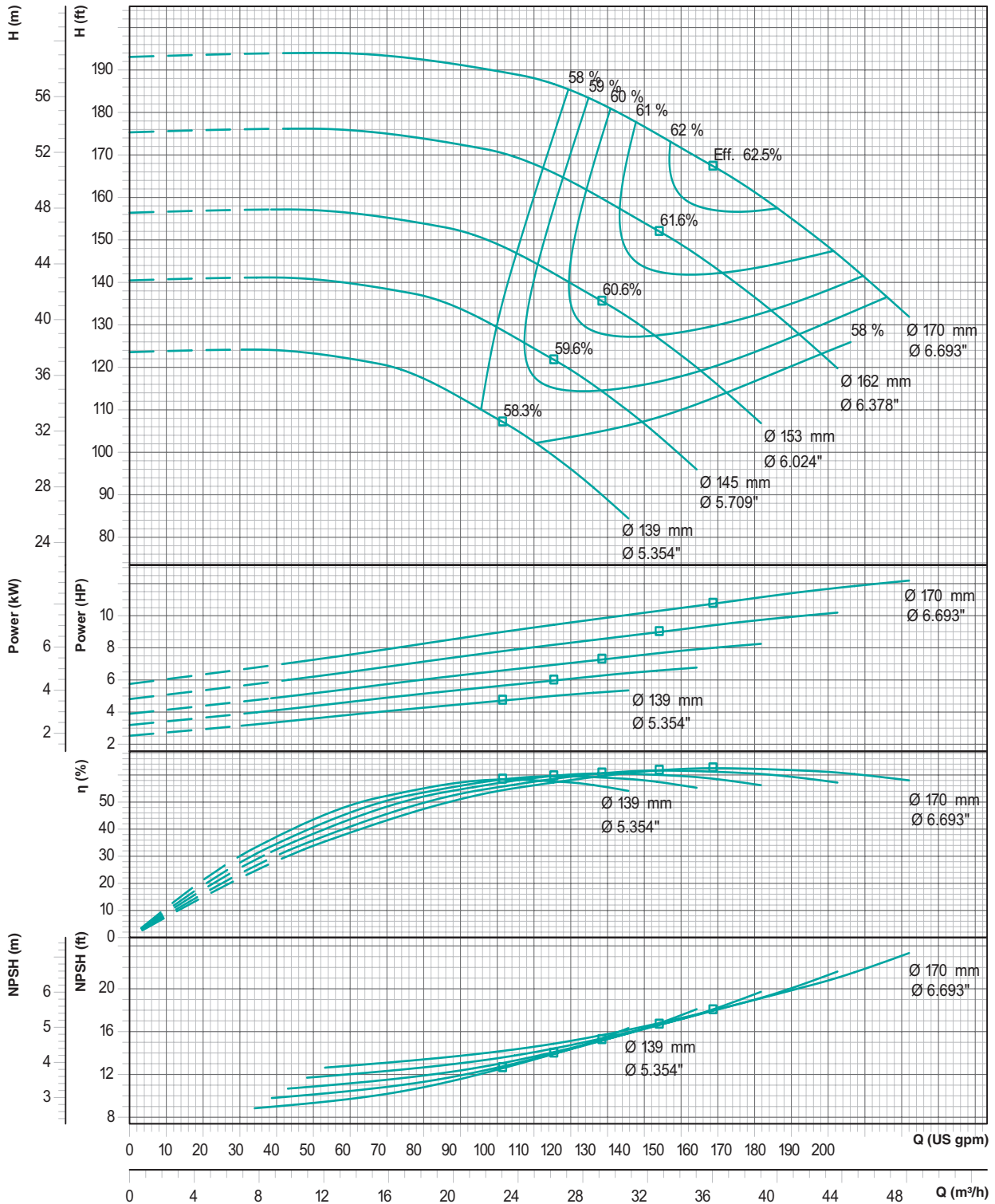

Performance curve tolerances are as per HI : 14.6 / ISO: 9906, Grade 2B

The Company reserves the right to modify the technical specifications and illustrations without prior notice.

PERFORMANCE CURVES

Model : **TEH-32-160E**

Speed : **1750 rpm**

Suc x Del (in mm) : **50 x 32**

Max. Impeller Ø : **174mm**

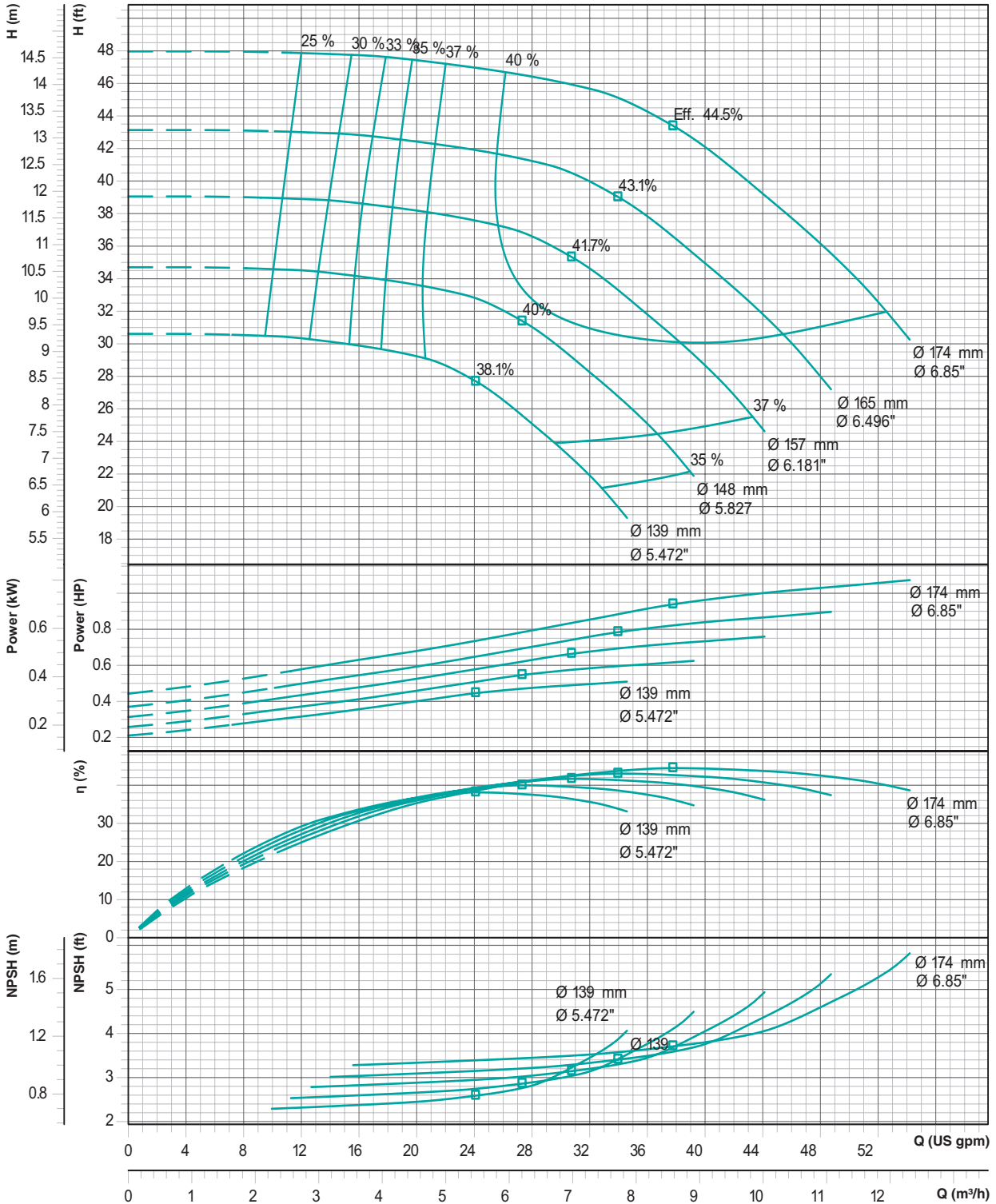

Performance curve tolerances are as per HI : 14.6 / ISO: 9906, Grade 2B

The Company reserves the right to modify the technical specifications and illustrations without prior notice.

PERFORMANCE CURVES

Model : **TEH-32-160E**

Speed : **3500 rpm**

Suc x Del (in mm) : **50 x 32**

Max. Impeller Ø : **174mm**

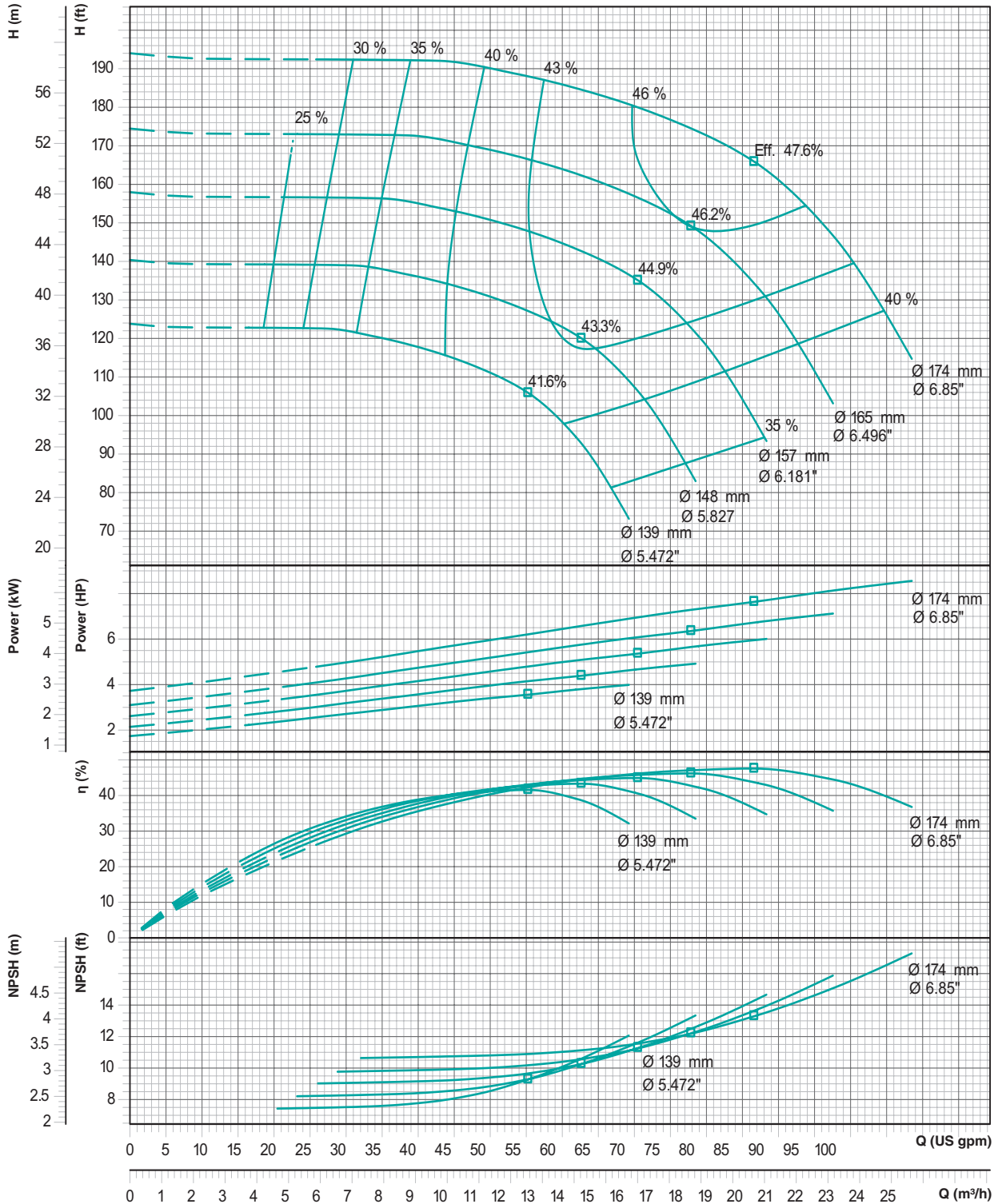

Performance curve tolerances are as per HI : 14.6 / ISO: 9906, Grade 2B

The Company reserves the right to modify the technical specifications and illustrations without prior notice.

PERFORMANCE CURVES

Model : **TEH-32-200**

Speed : **1750 rpm**

Suc x Del (in mm) : **50 x 32**

Max. Impeller Ø : **209mm**

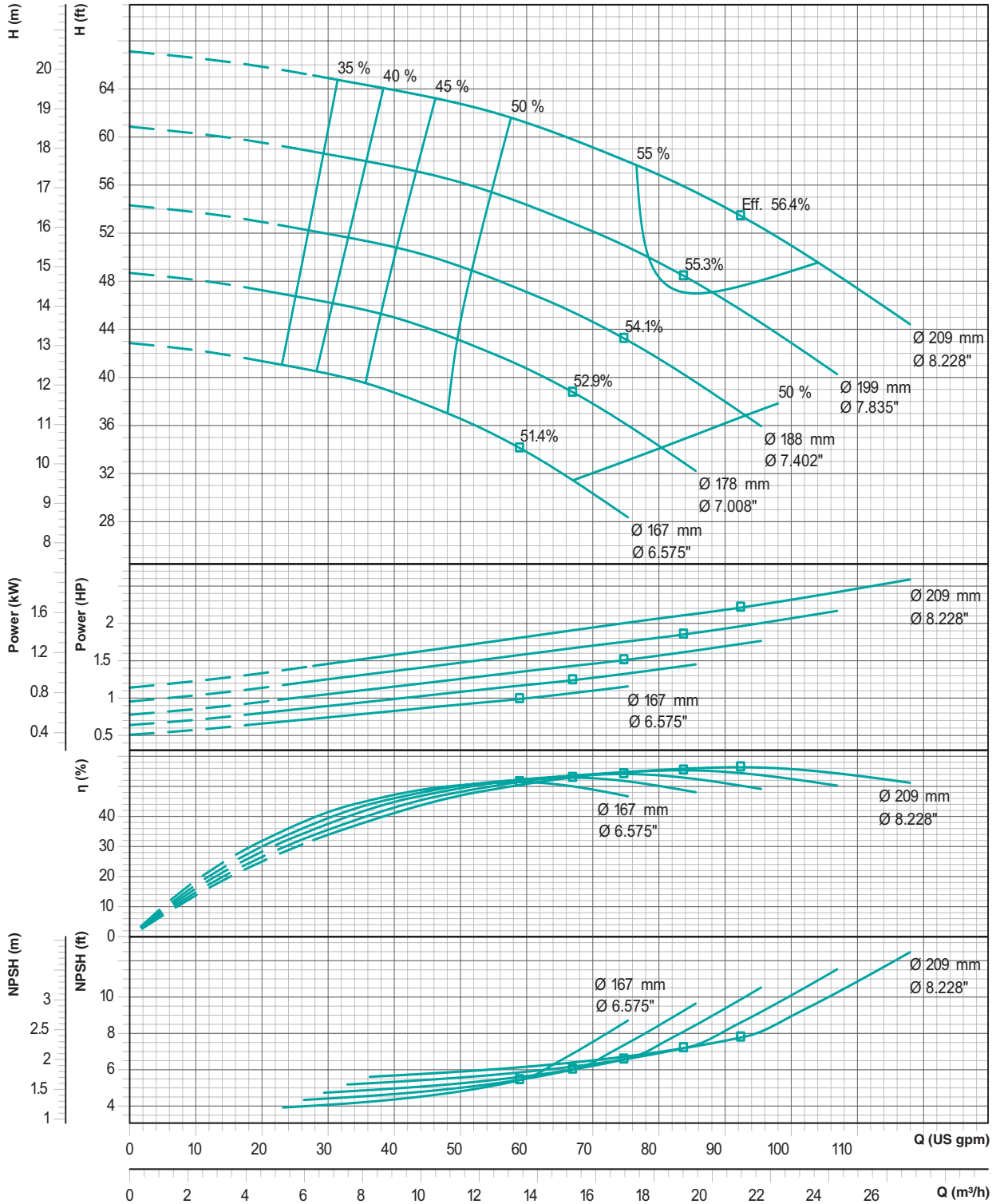

Performance curve tolerances are as per HI : 14.6 / ISO: 9906, Grade 2B

The Company reserves the right to modify the technical specifications and illustrations without prior notice.

PERFORMANCE CURVES

Model : **TEH-32-200**

Speed : **3500 rpm**

Suc x Del (in mm) : **50 x 32**

Max. Impeller Ø : **209mm**

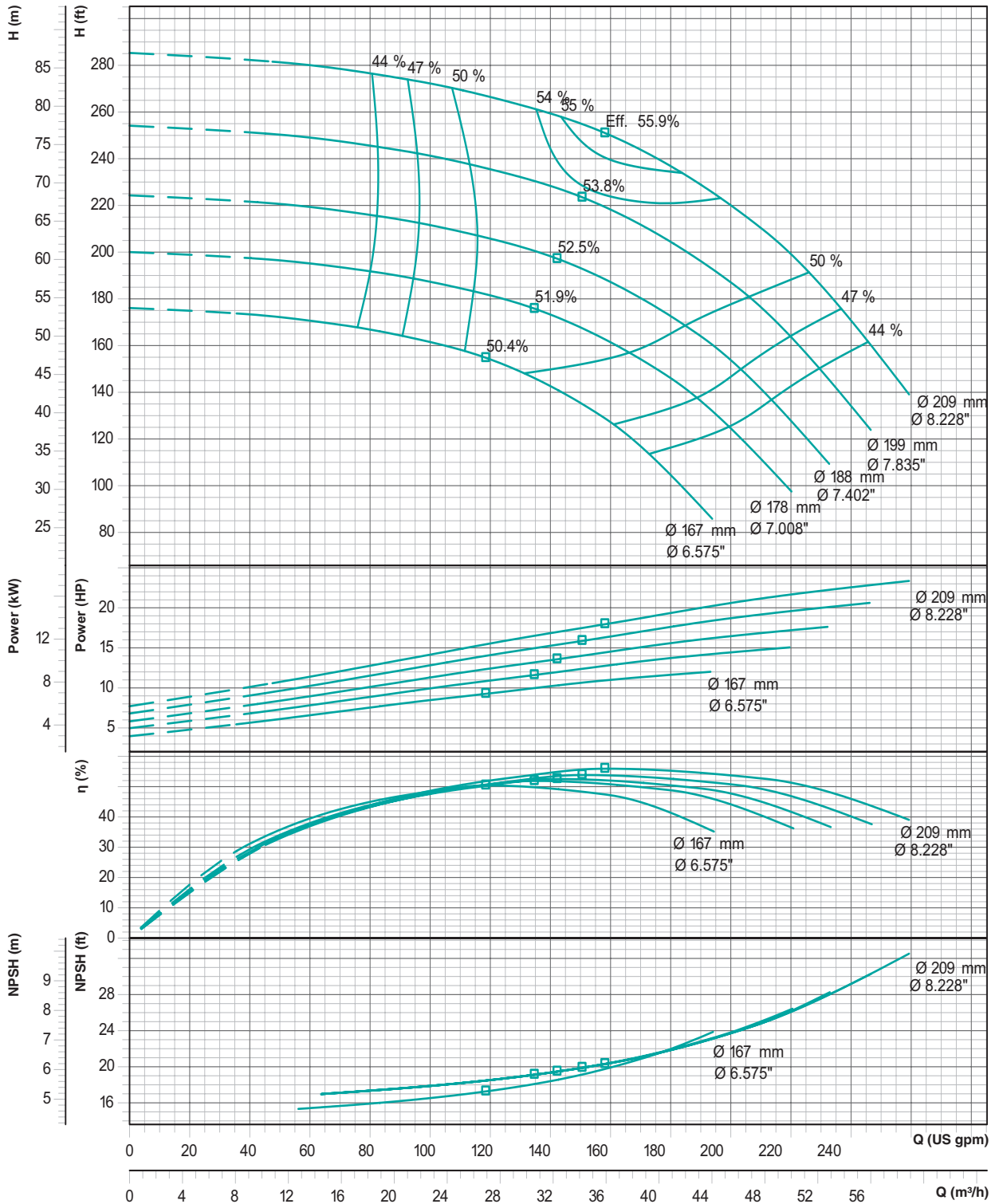

Performance curve tolerances are as per HI : 14.6 / ISO: 9906, Grade 2B

The Company reserves the right to modify the technical specifications and illustrations without prior notice.

PERFORMANCE CURVES

Model : **TEH-32-200E**

Speed : **1750 rpm**

Suc x Del (in mm) : **50 x 32**

Max. Impeller Ø : **204mm**

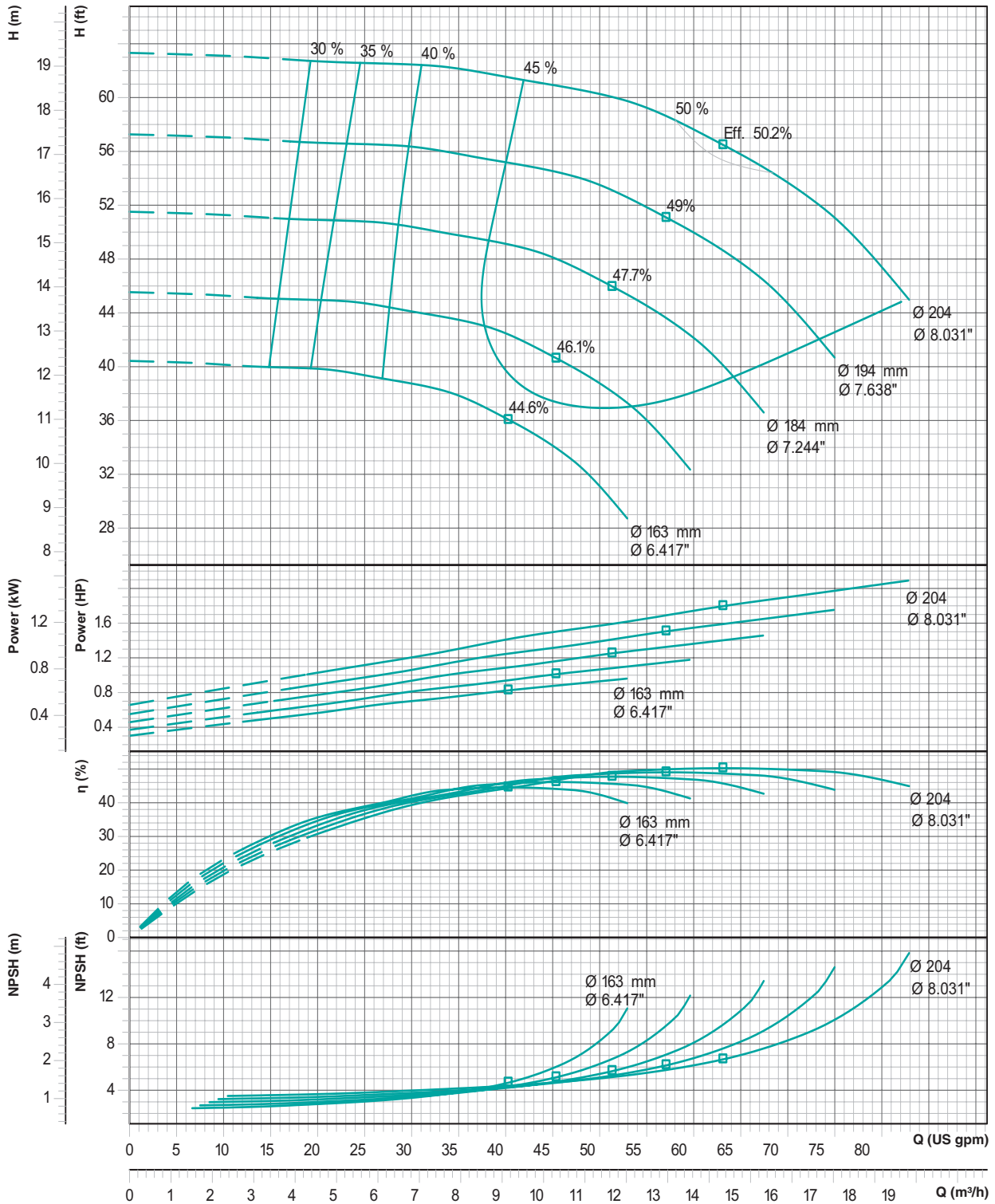

Performance curve tolerances are as per HI : 14.6 / ISO: 9906, Grade 2B

The Company reserves the right to modify the technical specifications and illustrations without prior notice.

PERFORMANCE CURVES

Model : **TEH-32-200E**

Speed : **3500 rpm**

Suc x Del (in mm) : **50 x 32**

Max. Impeller Ø : **204mm**

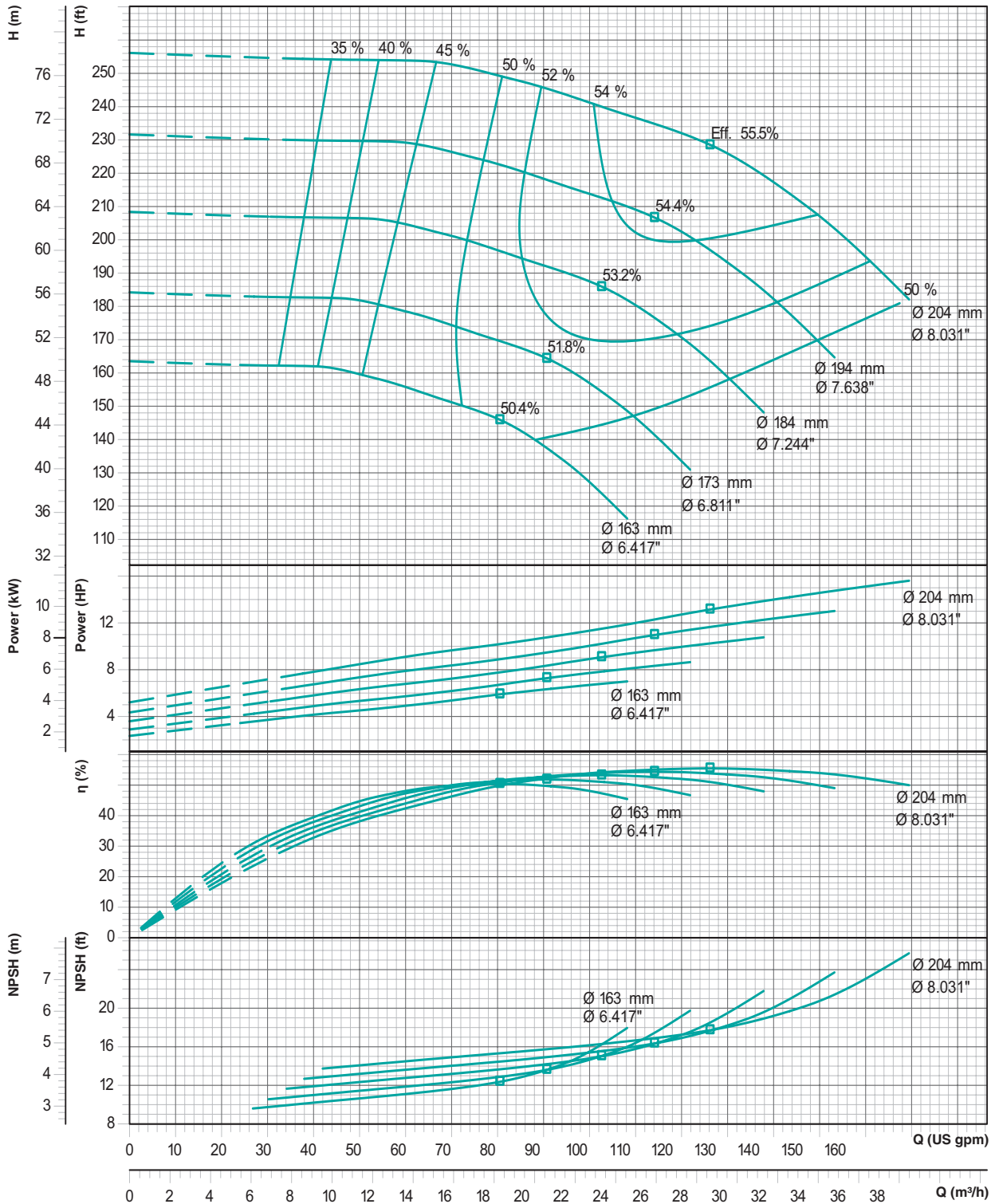

Performance curve tolerances are as per HI : 14.6 / ISO: 9906, Grade 2B

The Company reserves the right to modify the technical specifications and illustrations without prior notice.

PERFORMANCE CURVES

Model : **TEH-32-250**

Speed : **1750 rpm**

Suc x Del (in mm) : **50 x 32**

Max. Impeller Ø : **261 mm**

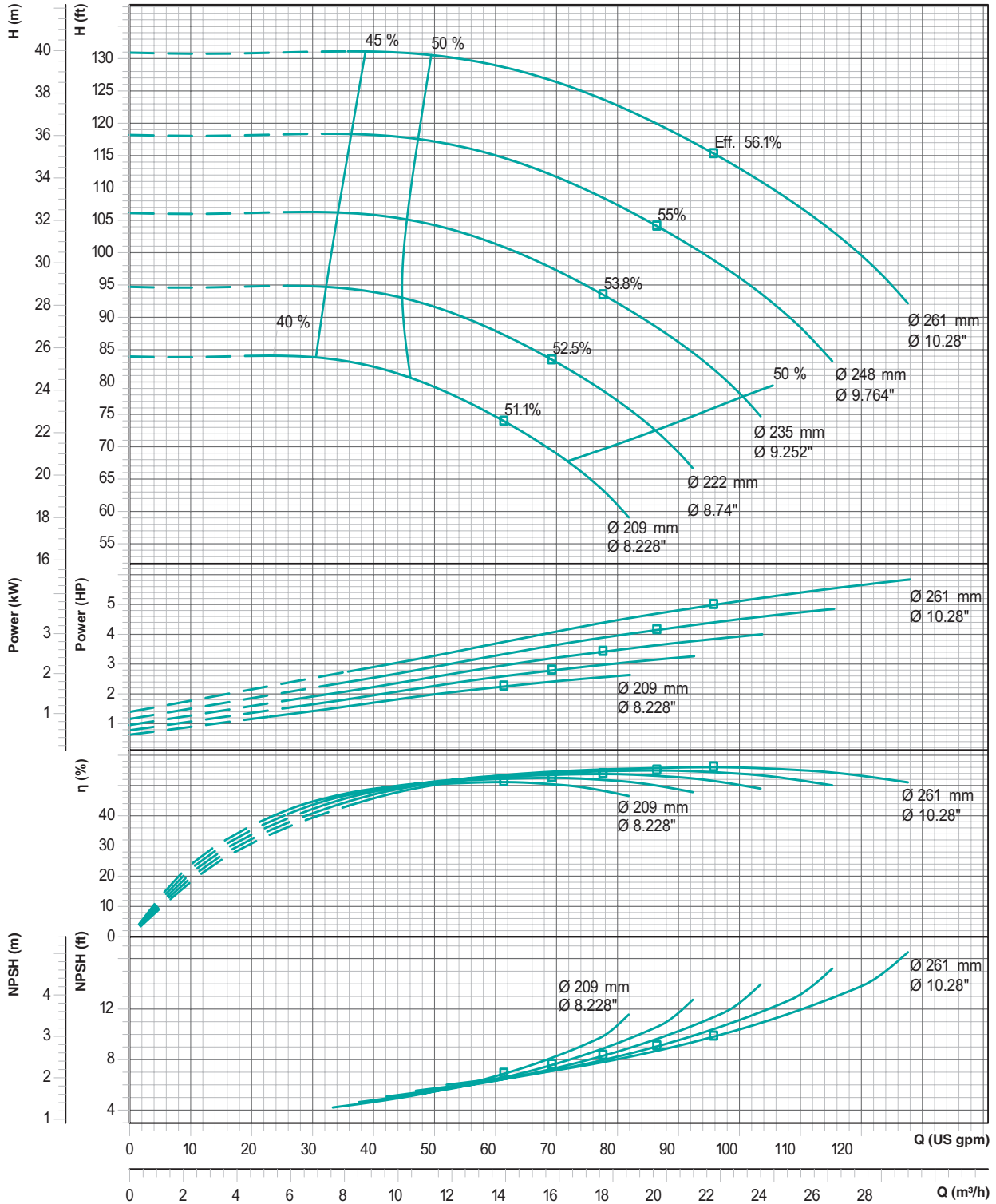

Performance curve tolerances are as per HI : 14.6 / ISO: 9906, Grade 2B

The Company reserves the right to modify the technical specifications and illustrations without prior notice.

PERFORMANCE CURVES

Model : **TEH-32-250**

Speed : **3500 rpm**

Suc x Del (in mm) : **50 x 32**

Max. Impeller Ø : **261 mm**

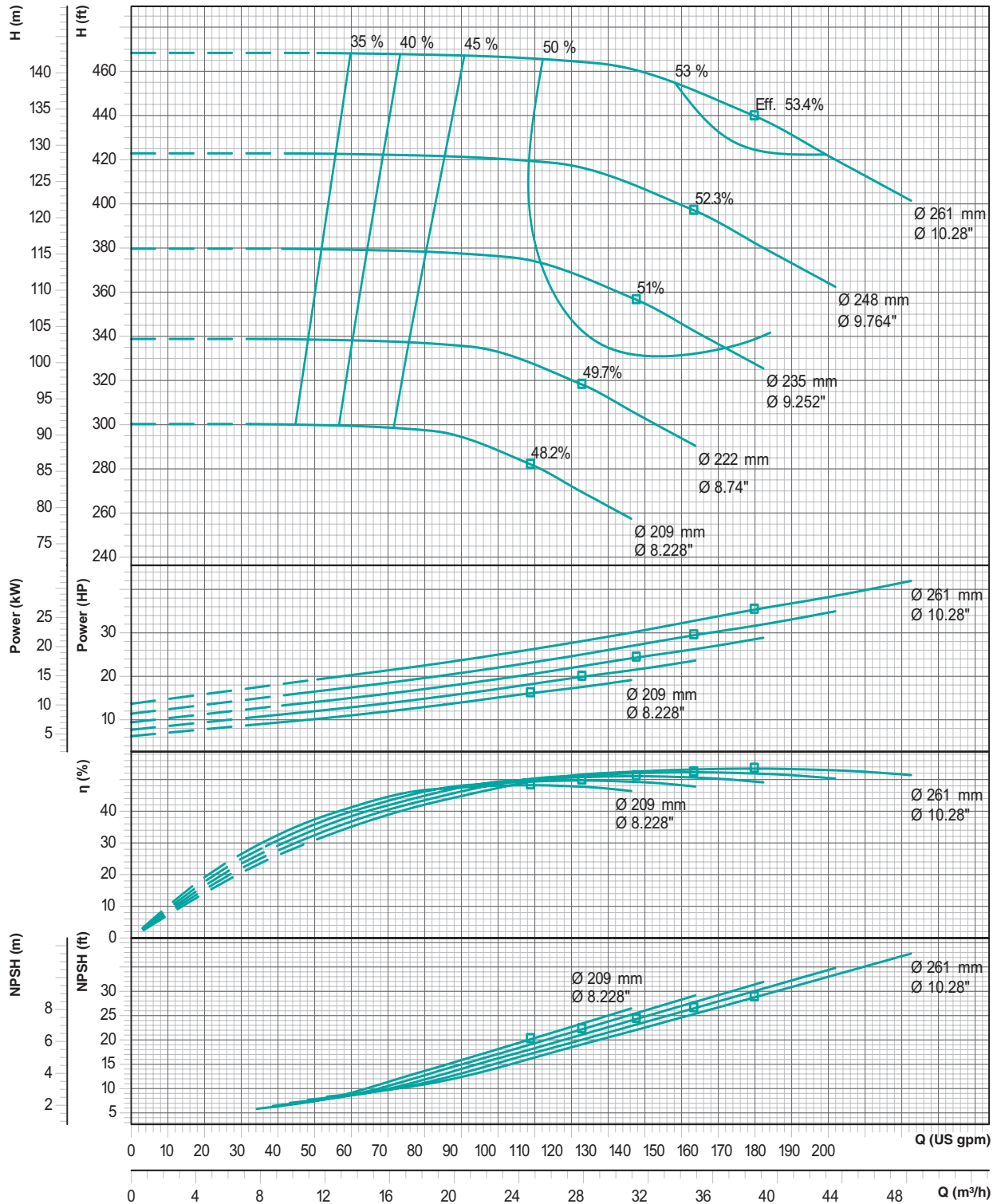

Performance curve tolerances are as per HI : 14.6 / ISO: 9906, Grade 2B

The Company reserves the right to modify the technical specifications and illustrations without prior notice.

PERFORMANCE CURVES

Model : **TEH-32-250E**

Speed : **1750 rpm**

Suc x Del (in mm) : **50 x 32**

Max. Impeller Ø : **254mm**

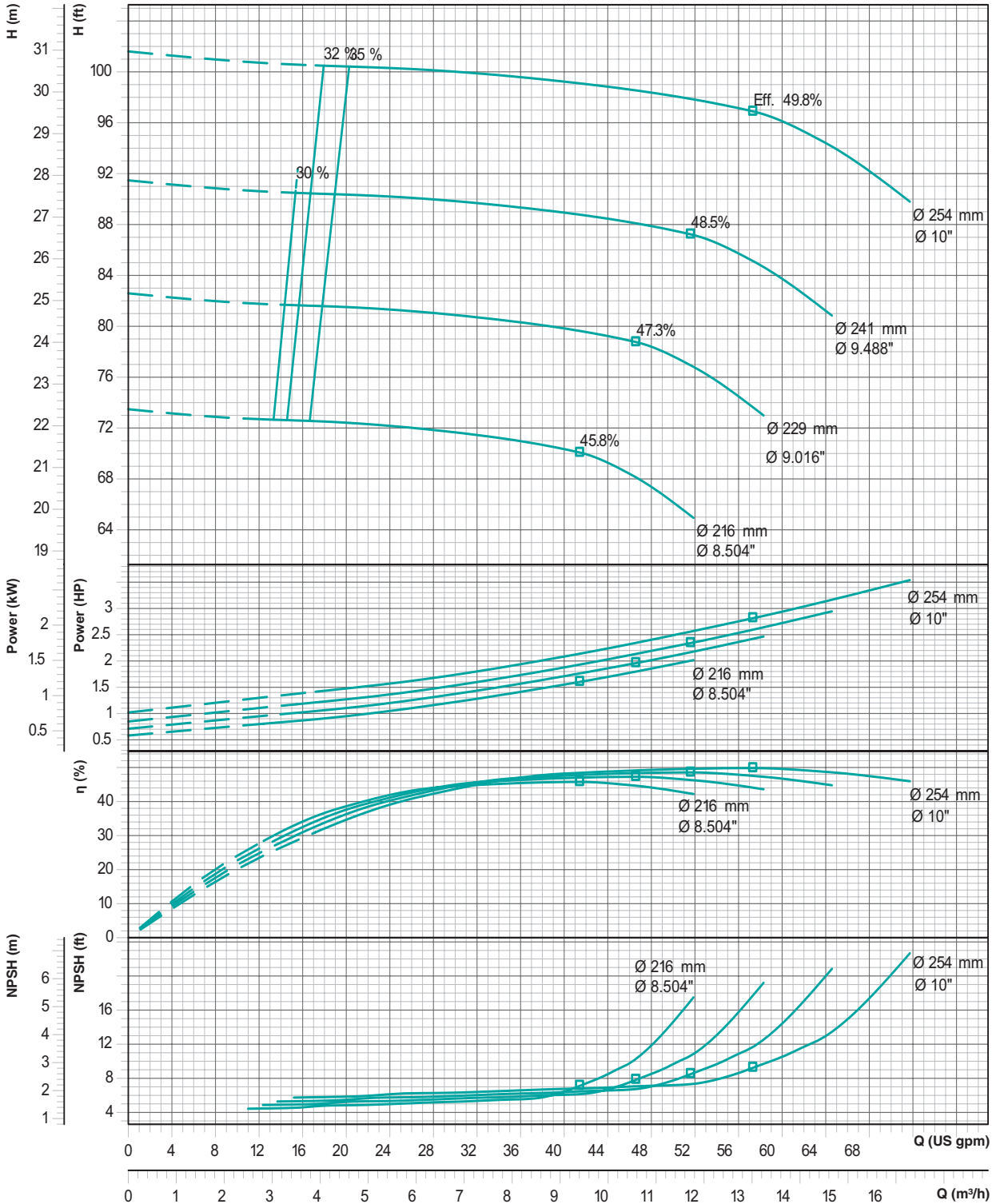

Performance curve tolerances are as per HI : 14.6 / ISO: 9906, Grade 2B

The Company reserves the right to modify the technical specifications and illustrations without prior notice.

PERFORMANCE CURVES

Model : **TEH-32-250E**

Speed : **3500 rpm**

Suc x Del (in mm) : **50 x 32**

Max. Impeller Ø : **254mm**

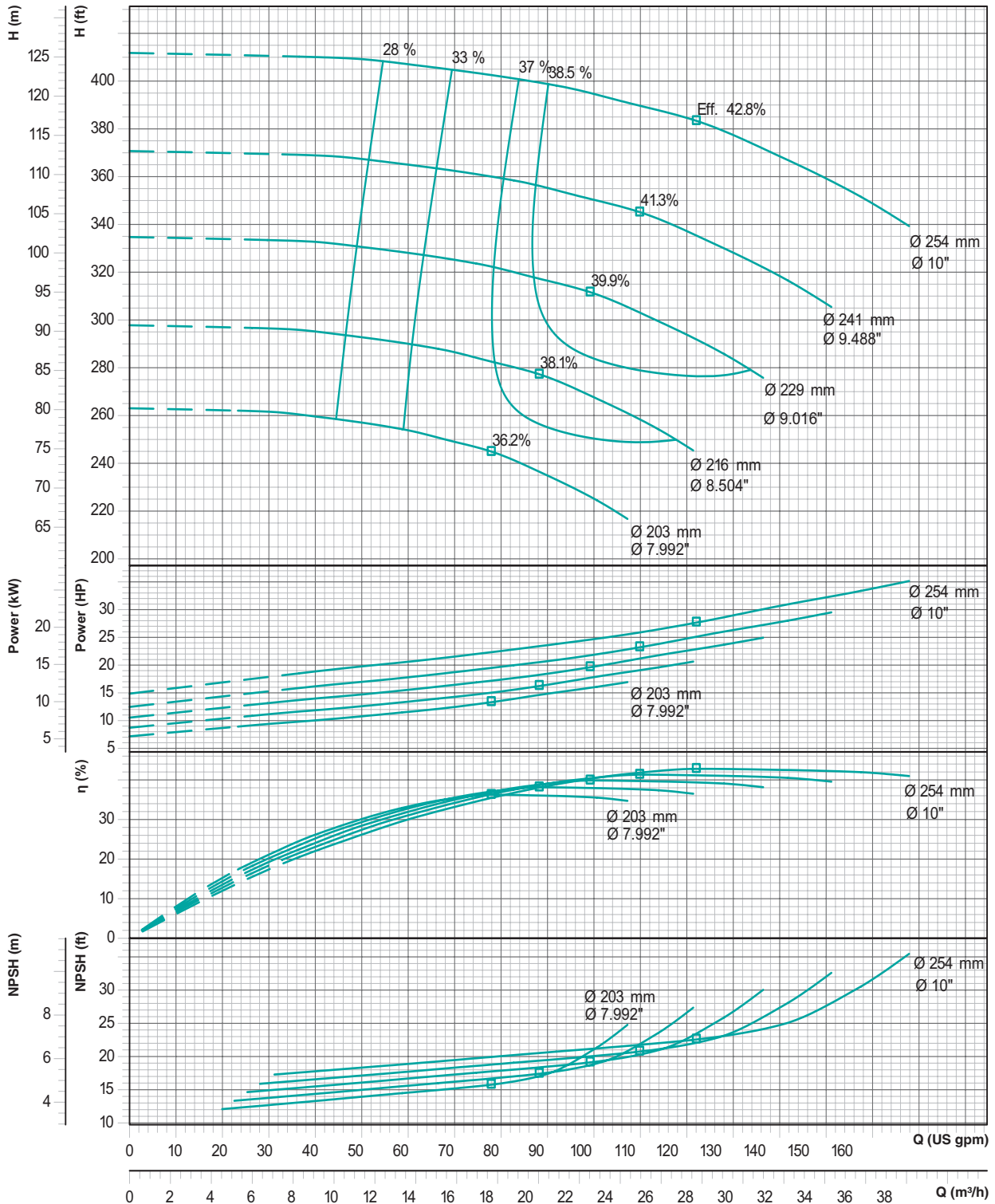

Performance curve tolerances are as per HI : 14.6 / ISO: 9906, Grade 2B

The Company reserves the right to modify the technical specifications and illustrations without prior notice.

PERFORMANCE CURVES

Model : **TEH-40-125**

Speed : **1750 rpm**

Suc x Del (in mm) : **65 x 40**

Max. Impeller Ø : **139mm**

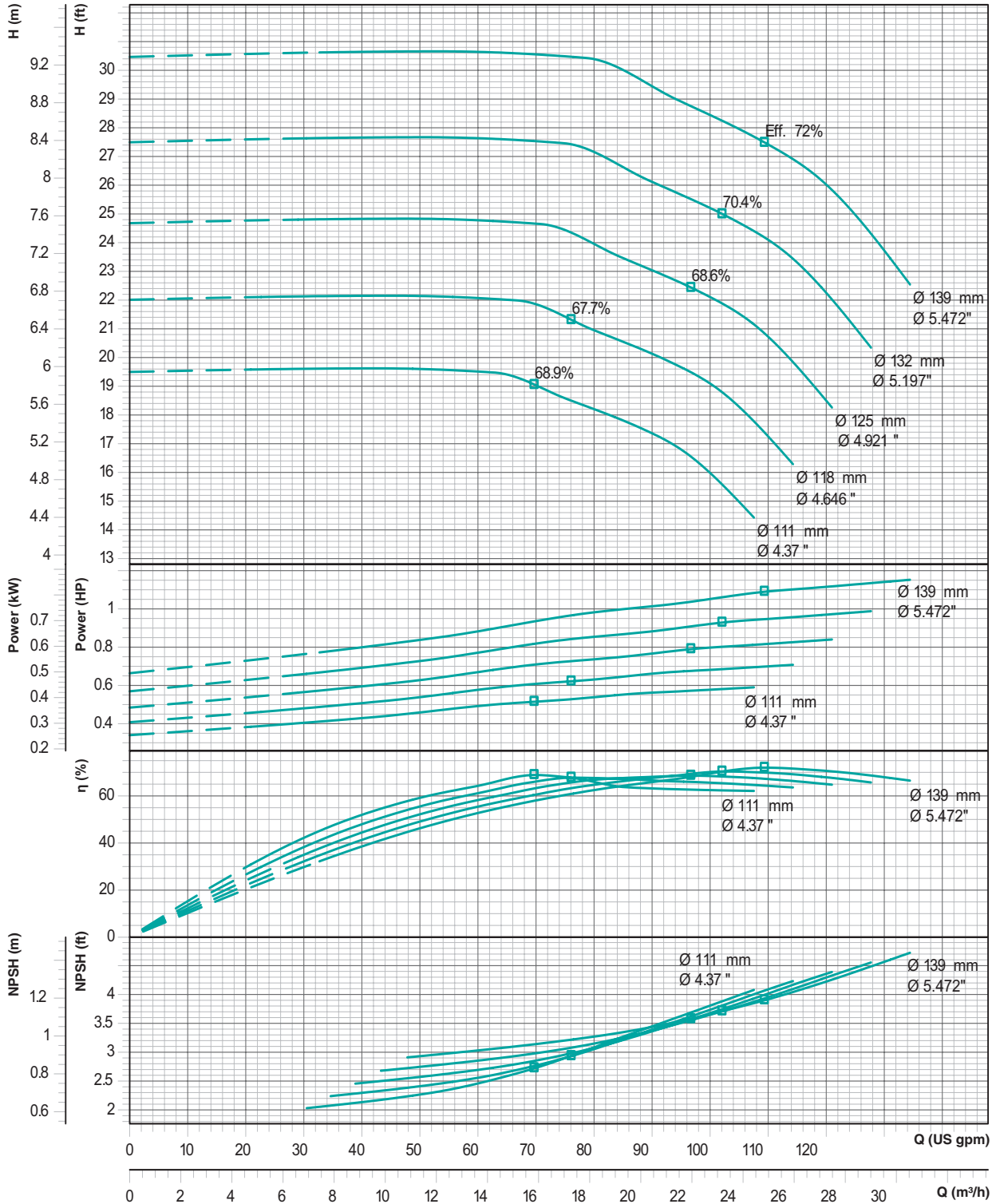

Performance curve tolerances are as per HI : 14.6 / ISO: 9906, Grade 2B

The Company reserves the right to modify the technical specifications and illustrations without prior notice.

PERFORMANCE CURVES

Model : **TEH-40-125**

Speed : **3500 rpm**

Suc x Del (in mm) : **65 x 40**

Max. Impeller Ø : **139mm**

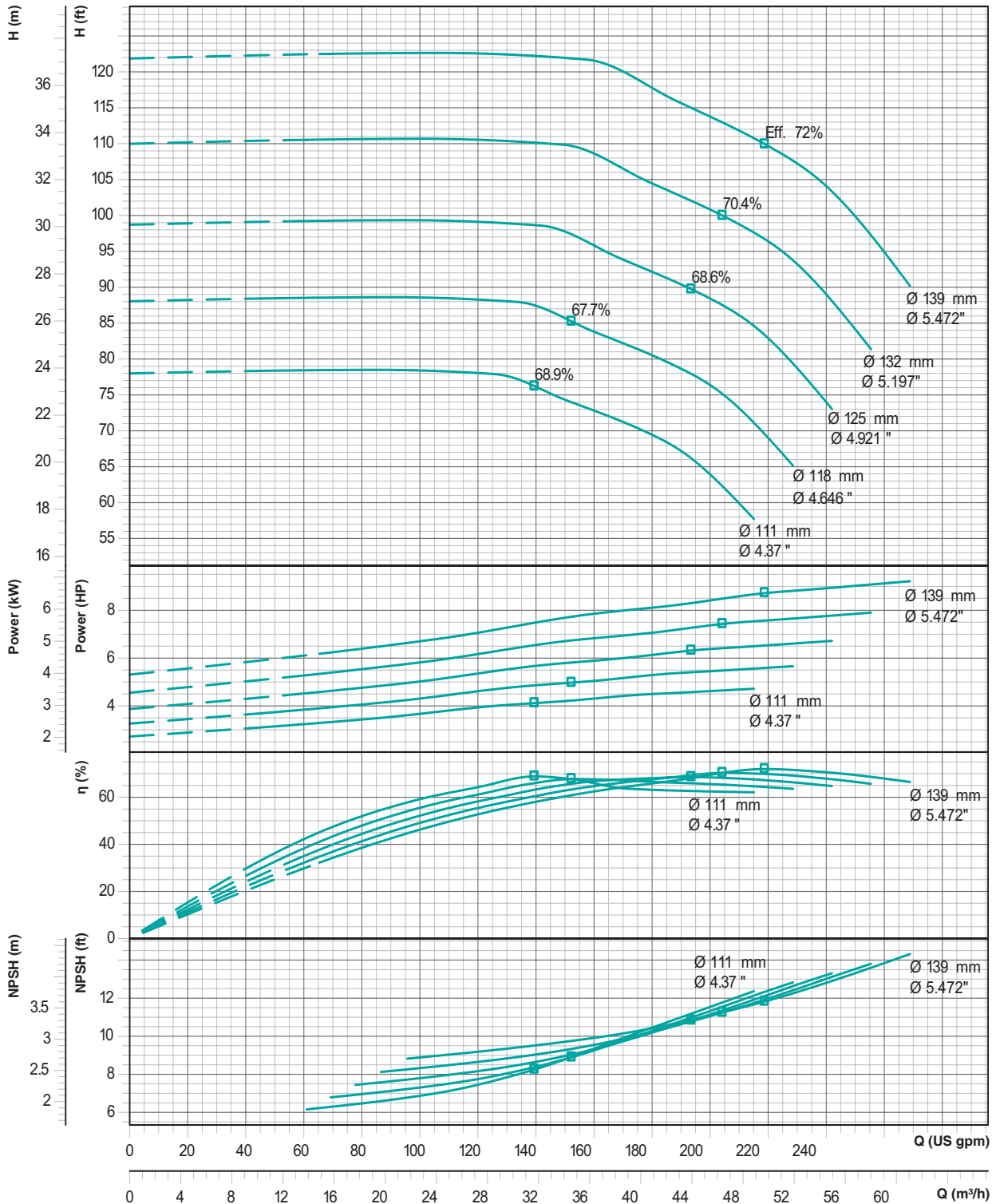

Performance curve tolerances are as per HI : 14.6 / ISO: 9906, Grade 2B

The Company reserves the right to modify the technical specifications and illustrations without prior notice.

PERFORMANCE CURVES

Model : **TEH-40-160**

Speed : **1750 rpm**

Suc x Del (in mm) : **65 x 40**

Max. Impeller Ø : **174mm**

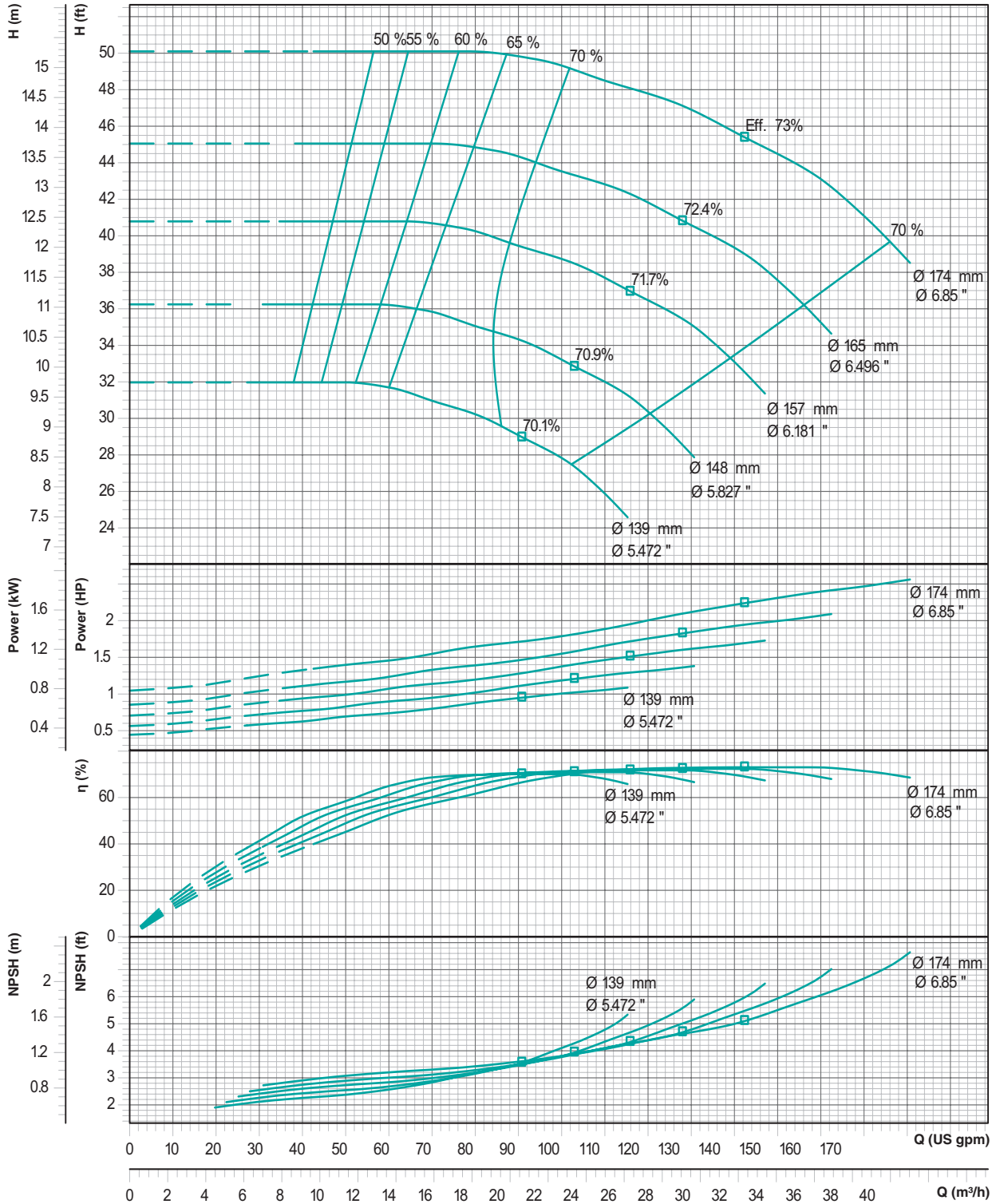

Performance curve tolerances are as per HI : 14.6 / ISO: 9906, Grade 2B

The Company reserves the right to modify the technical specifications and illustrations without prior notice.

PERFORMANCE CURVES

Model : **TEH-40-160**

Speed : **3500 rpm**

Suc x Del (in mm) : **65 x 40**

Max. Impeller Ø : **174mm**

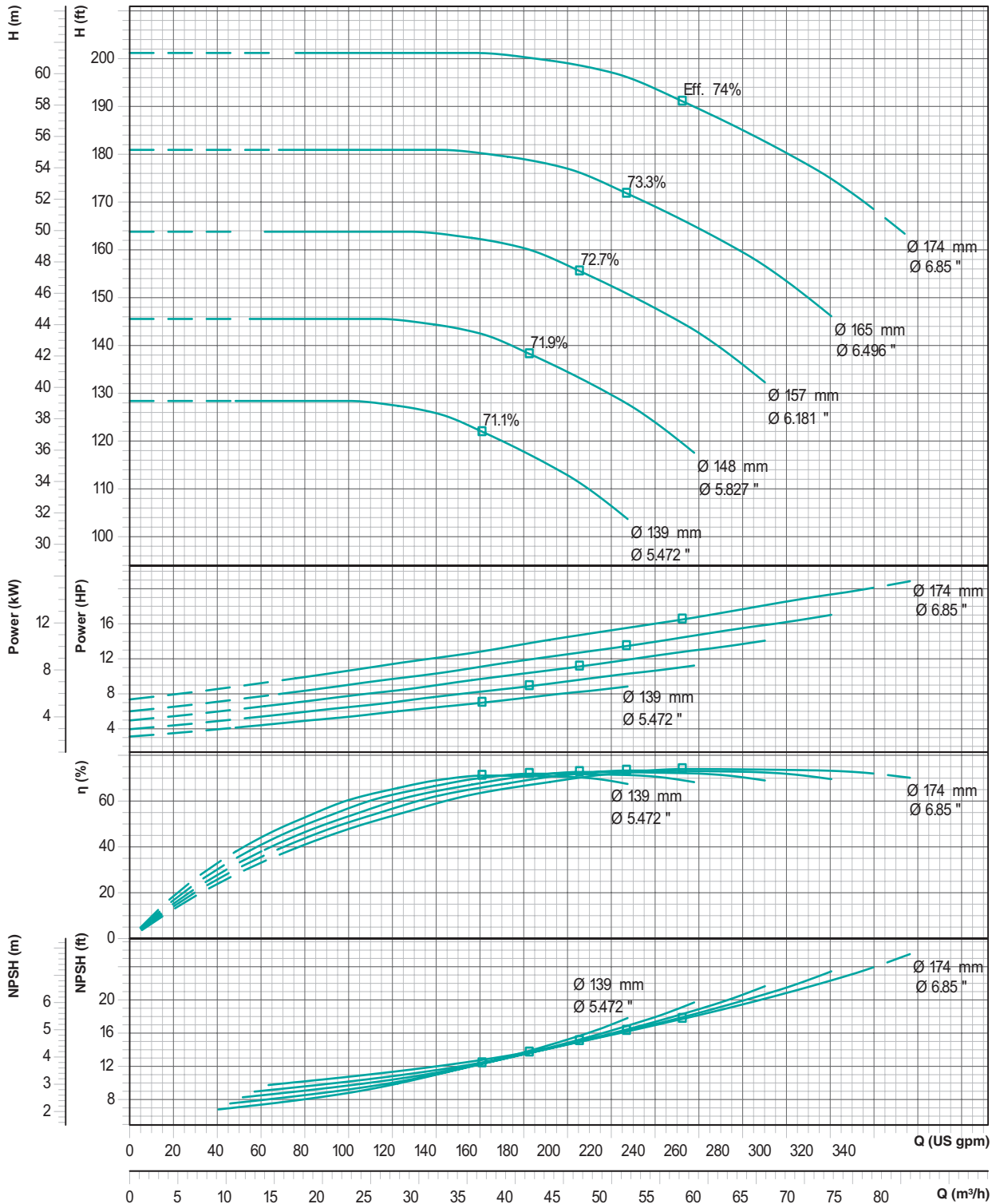

Performance curve tolerances are as per HI : 14.6 / ISO: 9906, Grade 2B

The Company reserves the right to modify the technical specifications and illustrations without prior notice.

PERFORMANCE CURVES

Model : **TEH-40-200**

Speed : **1750 rpm**

Suc x Del (in mm) : **65 x 40**

Max. Impeller Ø : **209mm**

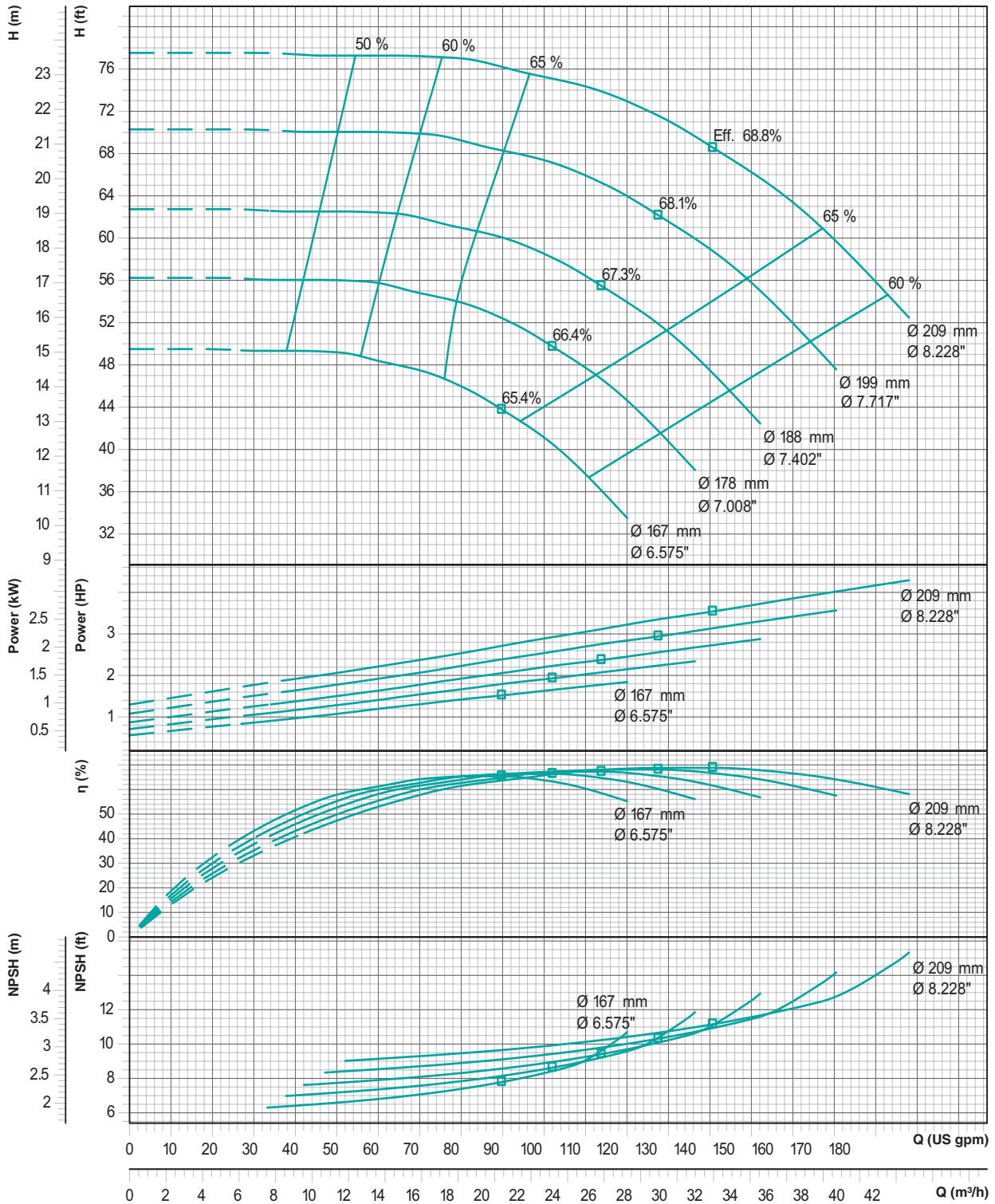

Performance curve tolerances are as per HI : 14.6 / ISO: 9906, Grade 2B

The Company reserves the right to modify the technical specifications and illustrations without prior notice.

PERFORMANCE CURVES

Model : **TEH-40-200**

Speed : **3500 rpm**

Suc x Del (in mm) : **65 x 40**

Max. Impeller Ø : **209mm**

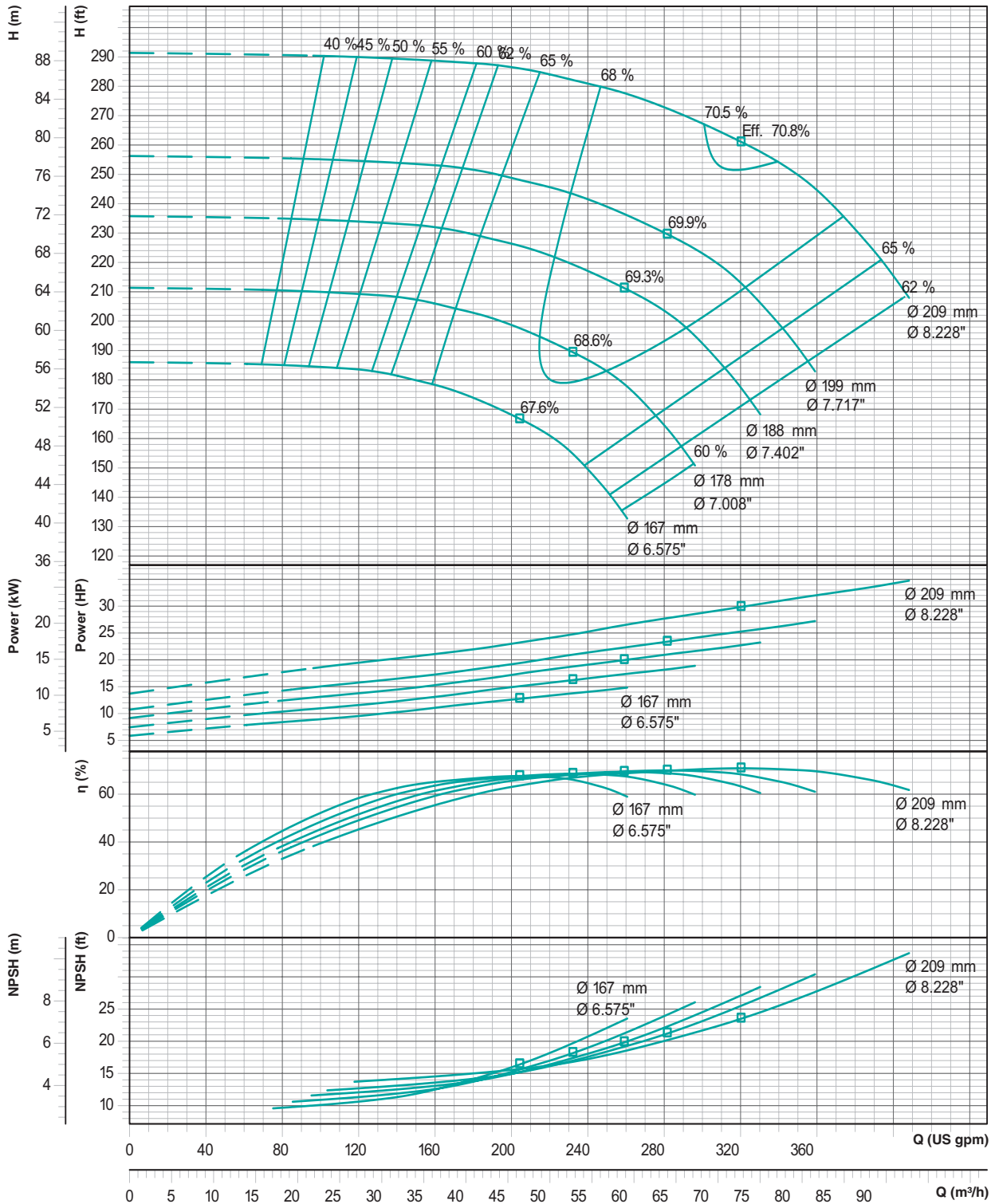

Performance curve tolerances are as per HI : 14.6 / ISO: 9906, Grade 2B

The Company reserves the right to modify the technical specifications and illustrations without prior notice.

PERFORMANCE CURVES

Model : **TEH-40-250**

Speed : **1750 rpm**

Suc x Del (in mm) : **65 x 40**

Max. Impeller Ø : **260mm**

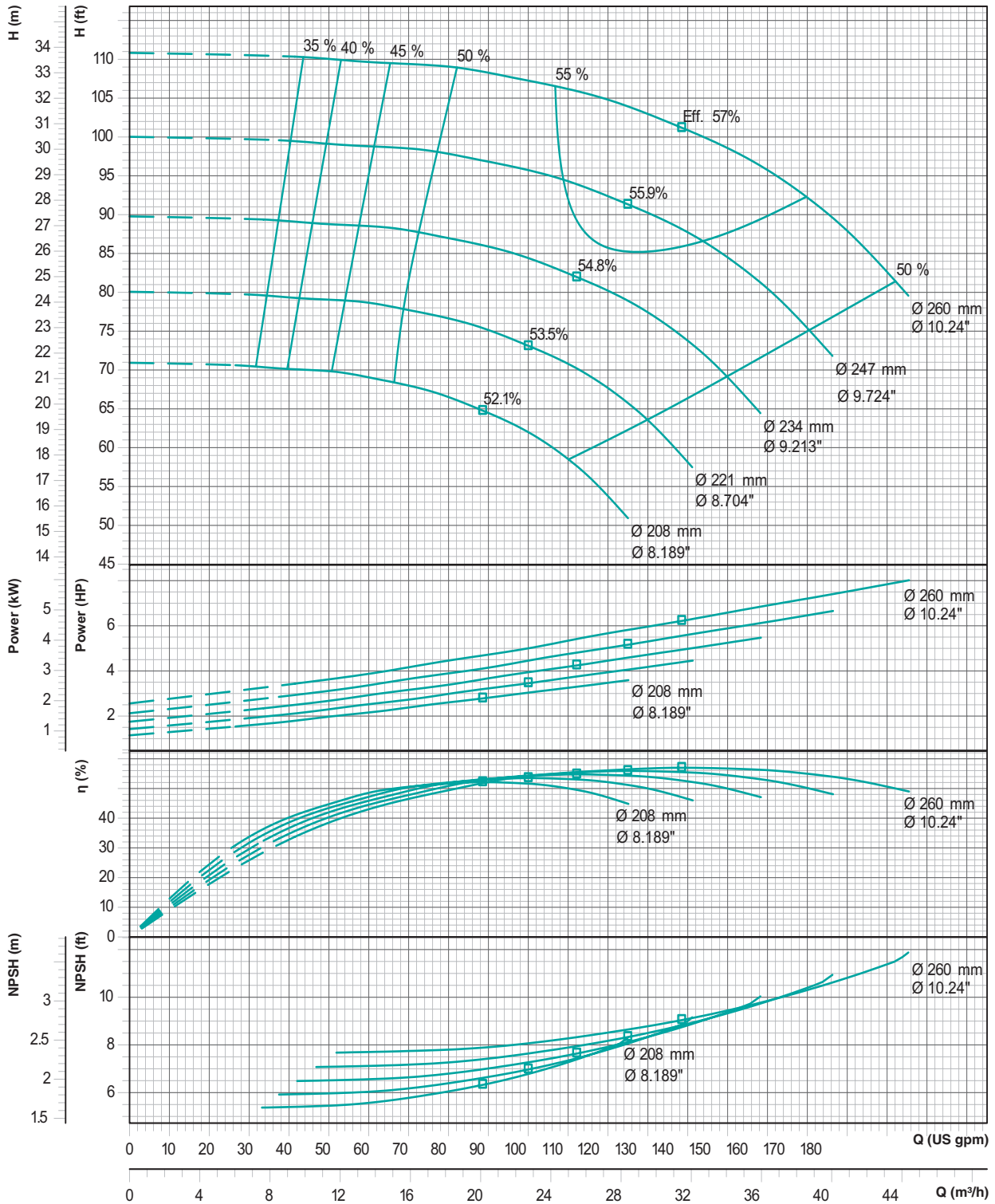

Performance curve tolerances are as per HI : 14.6 / ISO: 9906, Grade 2B

The Company reserves the right to modify the technical specifications and illustrations without prior notice.

PERFORMANCE CURVES

Model : **TEH-40-250**

Speed : **3500 rpm**

Suc x Del (in mm) : **65 x 40**

Max. Impeller Ø : **260mm**

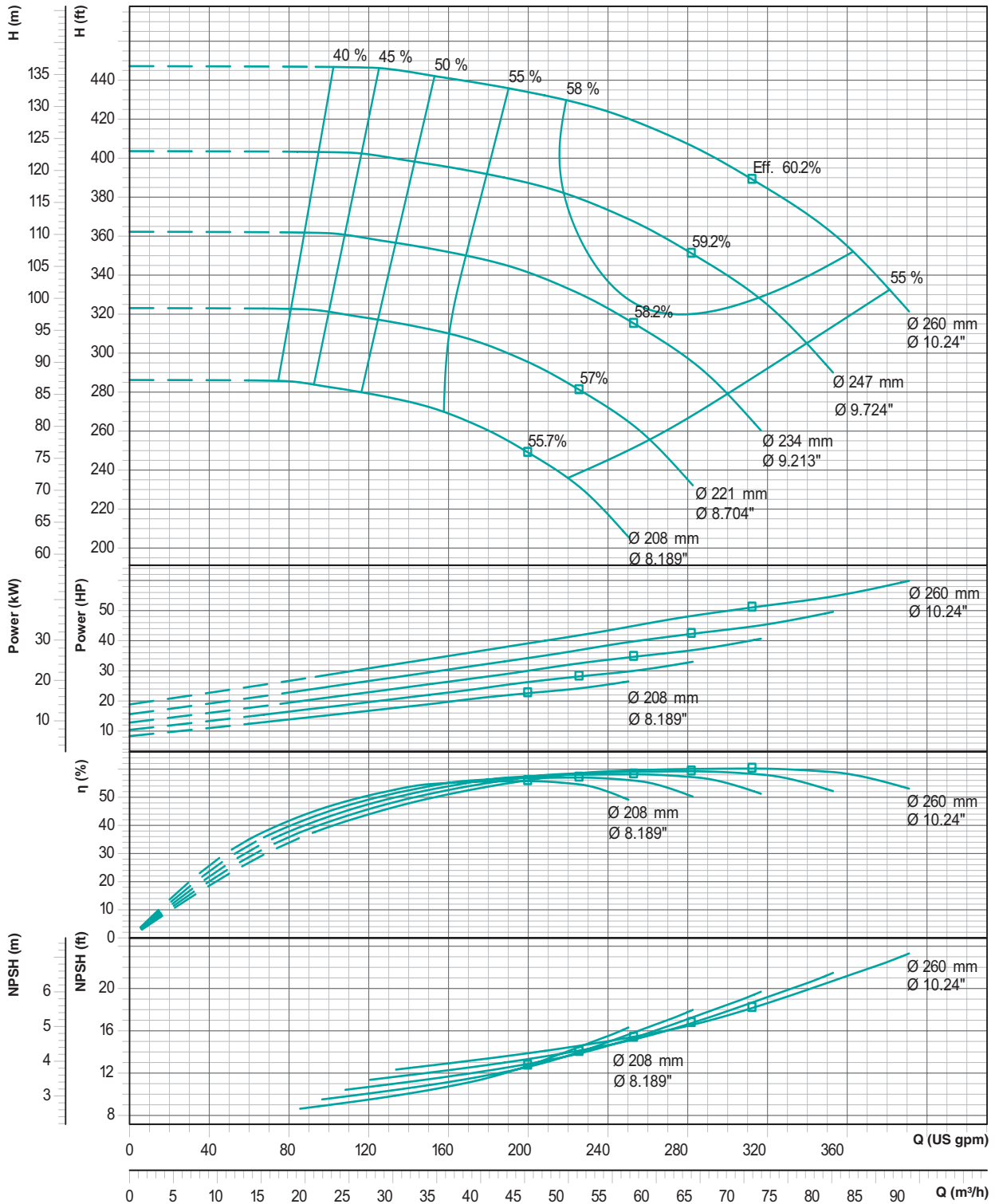

Performance curve tolerances are as per HI : 14.6 / ISO: 9906, Grade 2B

The Company reserves the right to modify the technical specifications and illustrations without prior notice.

PERFORMANCE CURVES

Model : **TEH-40-315**

Speed : **1750 rpm**

Suc x Del (in mm) : **65 x 40**

Max. Impeller Ø : **326mm**

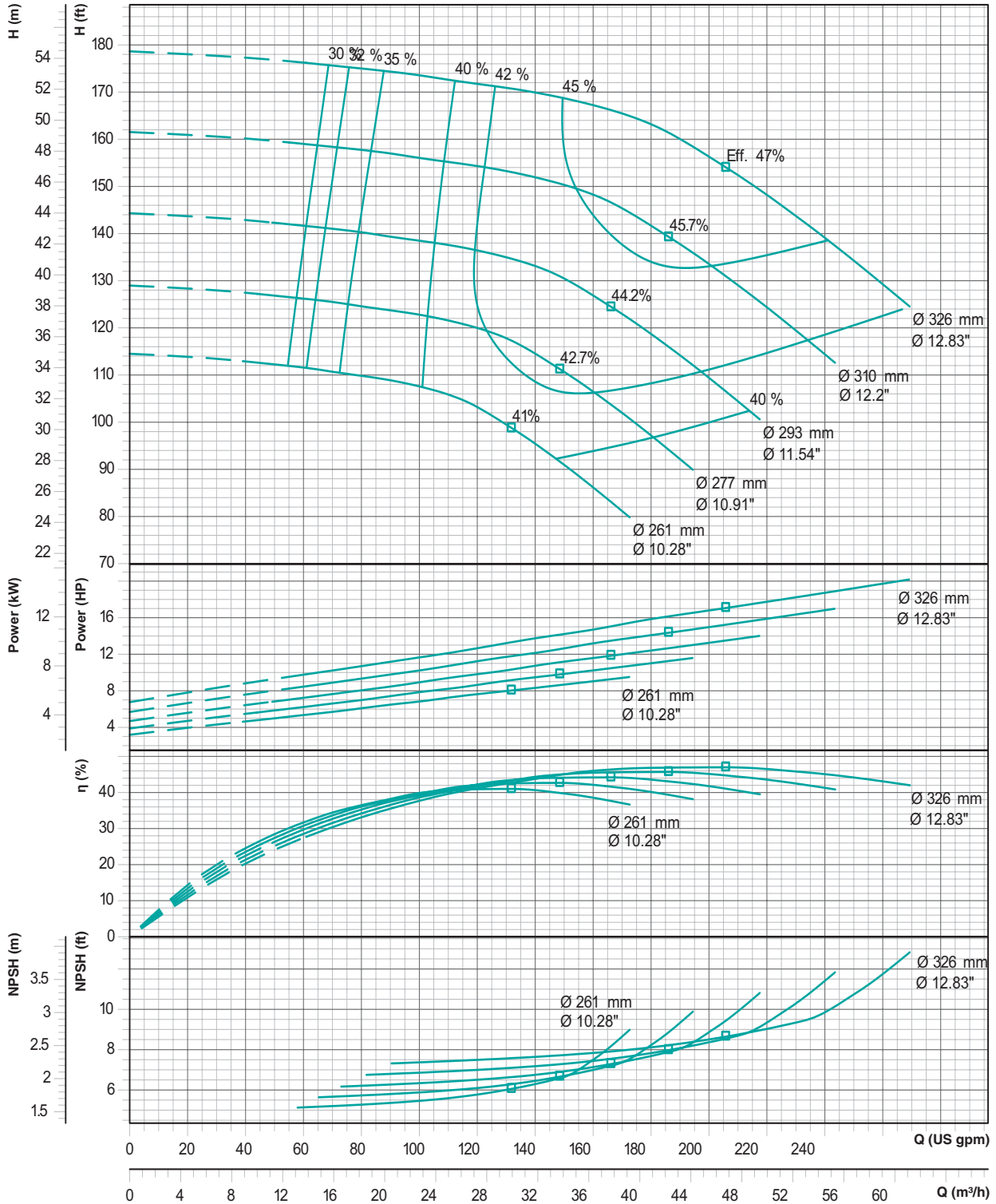

Performance curve tolerances are as per HI : 14.6 / ISO: 9906, Grade 2B

The Company reserves the right to modify the technical specifications and illustrations without prior notice.

PERFORMANCE CURVES

Model : **TEH-50-125**

Speed : **1750 rpm**

Suc x Del (in mm) : **65 x 50**

Max. Impeller Ø : **142mm**

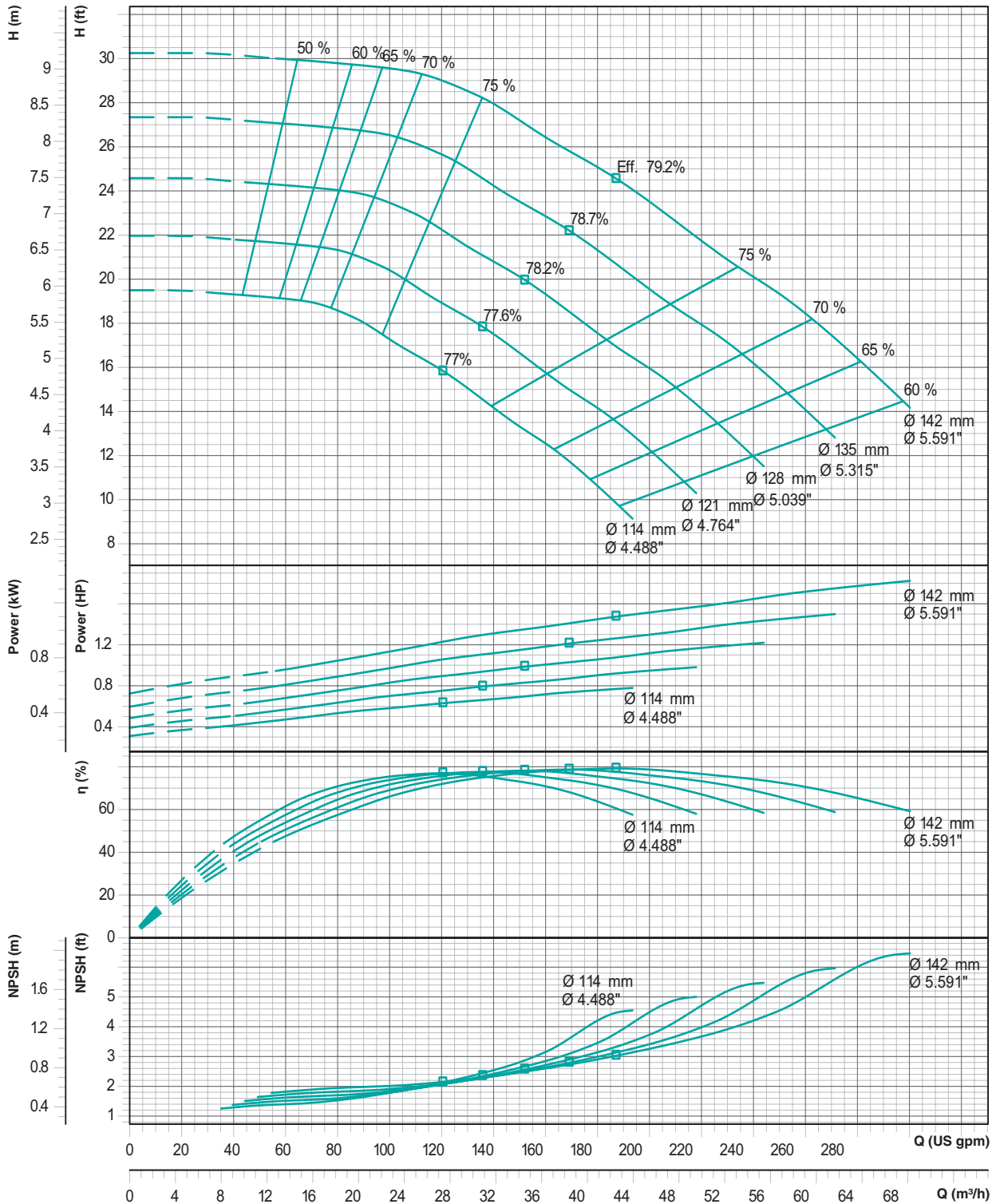

Performance curve tolerances are as per HI : 14.6 / ISO: 9906, Grade 2B

The Company reserves the right to modify the technical specifications and illustrations without prior notice.

PERFORMANCE CURVES

Model : **TEH-50-125**

Speed : **3500 rpm**

Suc x Del (in mm) : **65 x 50**

Max. Impeller Ø : **142mm**

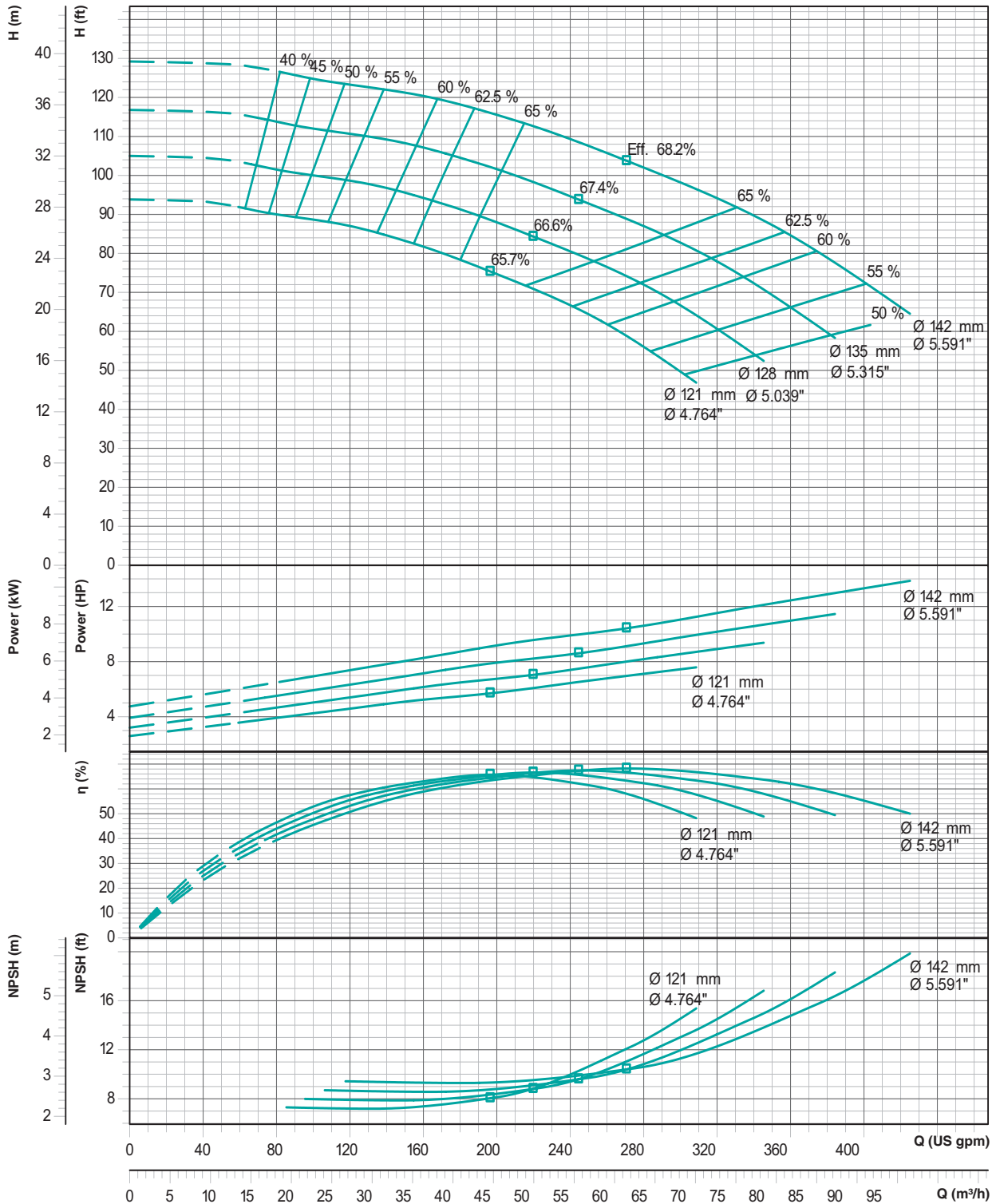

Performance curve tolerances are as per HI : 14.6 / ISO: 9906, Grade 2B

The Company reserves the right to modify the technical specifications and illustrations without prior notice.

PERFORMANCE CURVES

Model : **TEH-50-160**

Speed : **1750 rpm**

Suc x Del (in mm) : **65 x 50**

Max. Impeller Ø : **174mm**

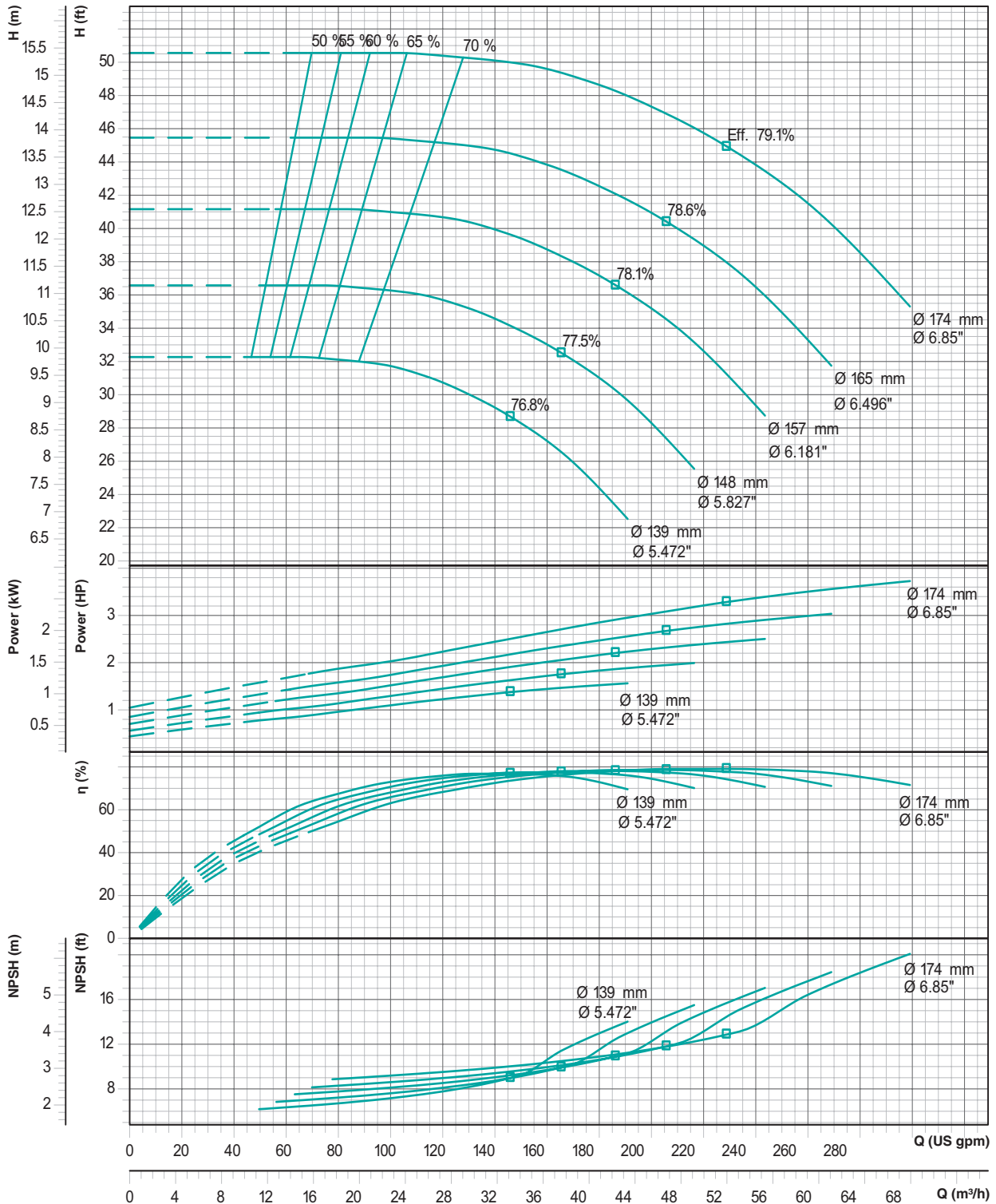

Performance curve tolerances are as per HI : 14.6 / ISO: 9906, Grade 2B

The Company reserves the right to modify the technical specifications and illustrations without prior notice.

PERFORMANCE CURVES

Model : **TEH-50-160**

Speed : **3500 rpm**

Suc x Del (in mm) : **65 x 50**

Max. Impeller Ø : **174mm**

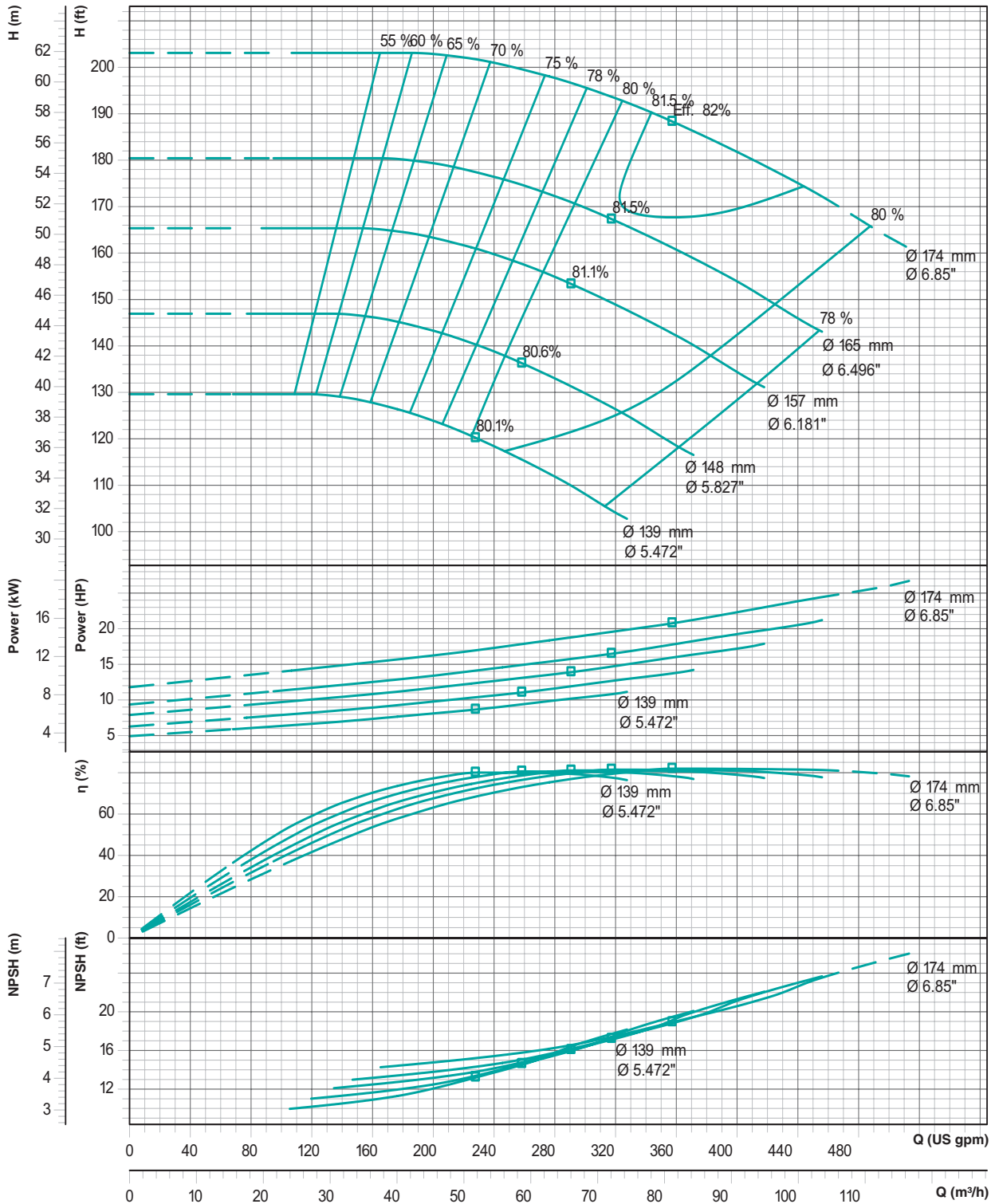

Performance curve tolerances are as per HI : 14.6 / ISO: 9906, Grade 2B

The Company reserves the right to modify the technical specifications and illustrations without prior notice.

PERFORMANCE CURVES

Model : **TEH-50-200**

Speed : **1750 rpm**

Suc x Del (in mm) : **65 x 50**

Max. Impeller Ø : **219mm**

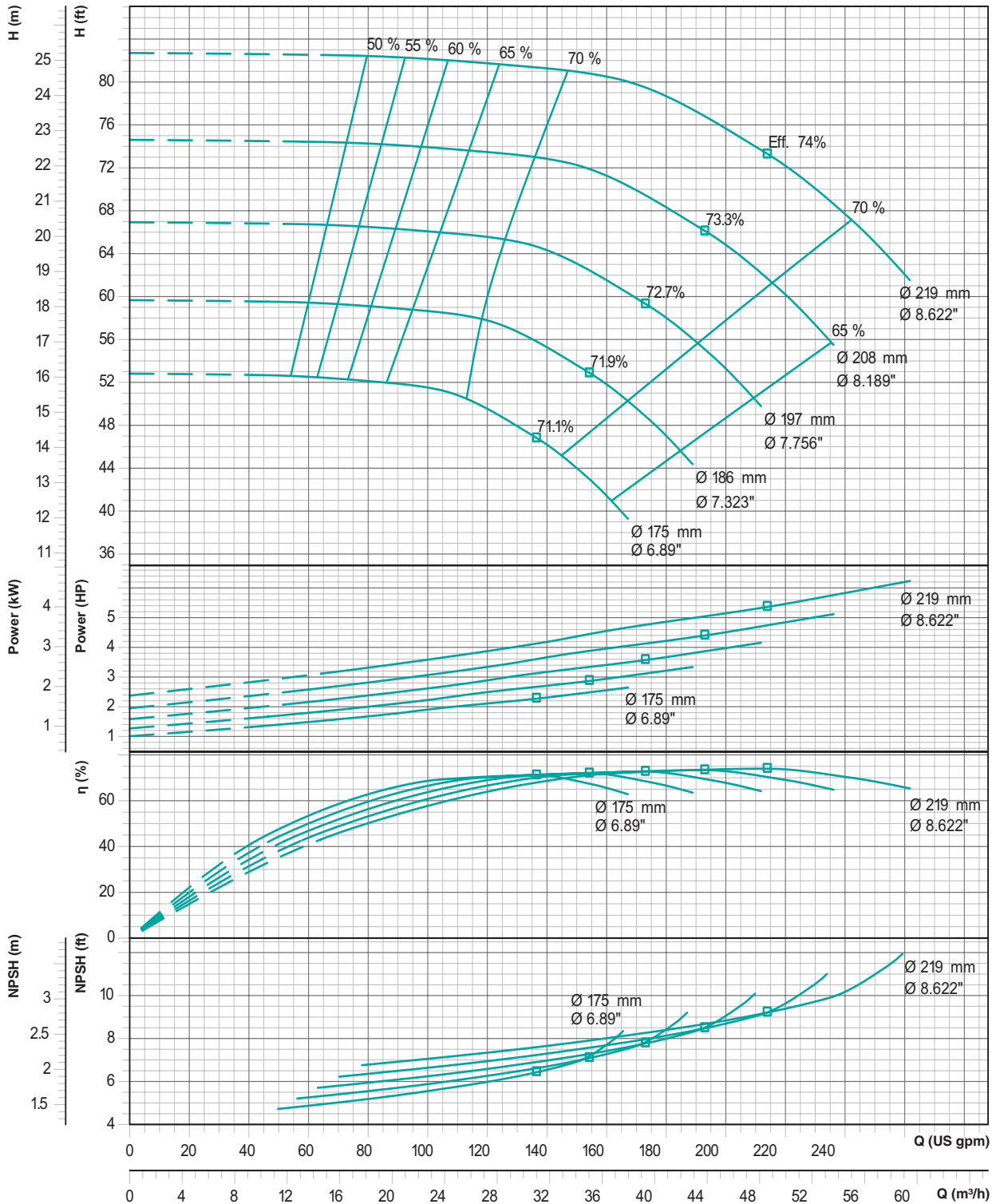

Performance curve tolerances are as per HI : 14.6 / ISO: 9906, Grade 2B

The Company reserves the right to modify the technical specifications and illustrations without prior notice.

PERFORMANCE CURVES

Model : **TEH-50-200**

Speed : **3500 rpm**

Suc x Del (in mm) : **65 x 50**

Max. Impeller Ø : **219mm**

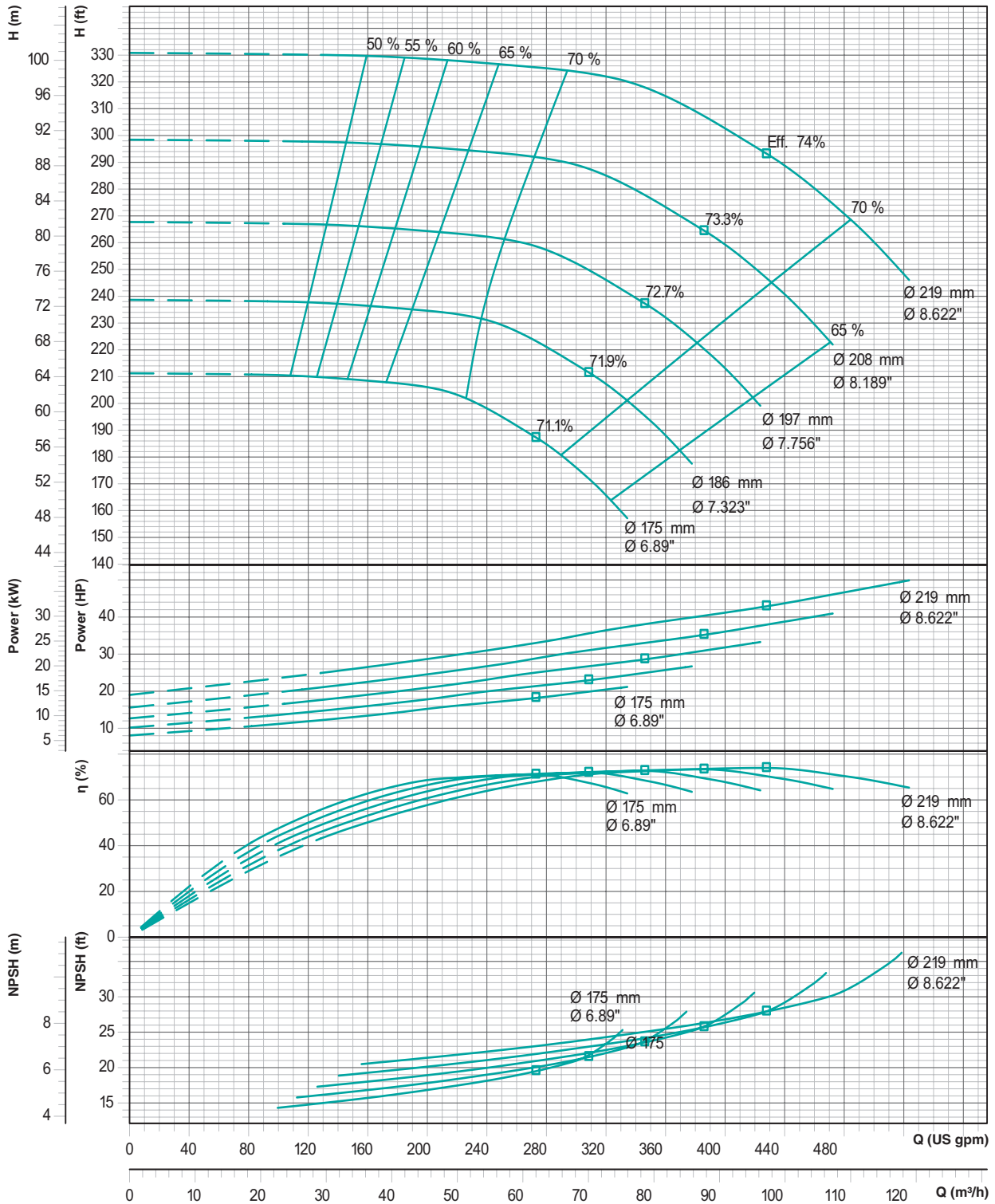

Performance curve tolerances are as per HI : 14.6 / ISO: 9906, Grade 2B

The Company reserves the right to modify the technical specifications and illustrations without prior notice.

PERFORMANCE CURVES

Model : **TEH-50-250**

Speed : **1750 rpm**

Suc x Del (in mm) : **65 x 50**

Max. Impeller Ø : **260mm**

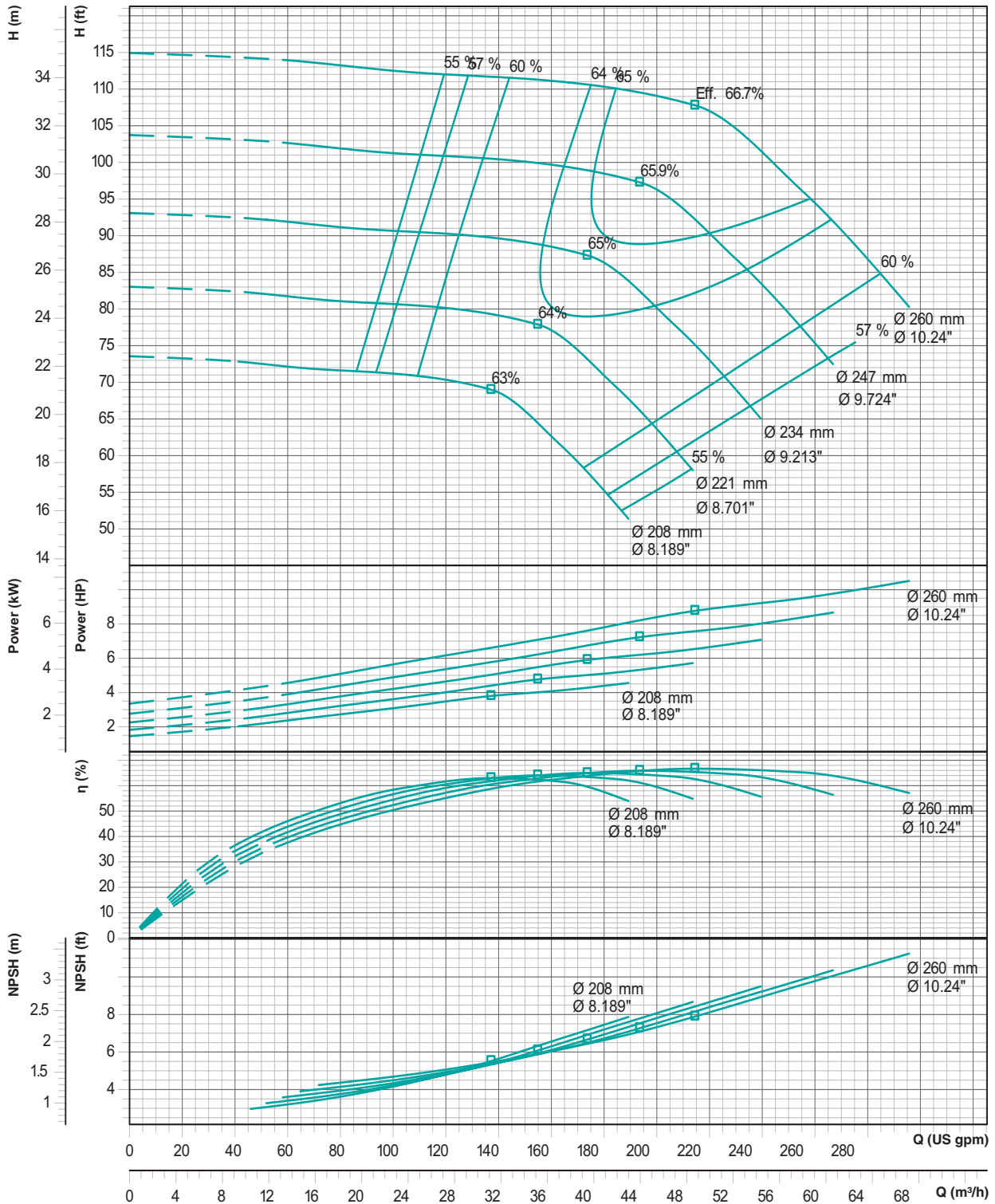

Performance curve tolerances are as per HI : 14.6 / ISO: 9906, Grade 2B

The Company reserves the right to modify the technical specifications and illustrations without prior notice.

PERFORMANCE CURVES

Model : **TEH-50-250**

Speed : **3500 rpm**

Suc x Del (in mm) : **65 x 50**

Max. Impeller Ø : **260mm**

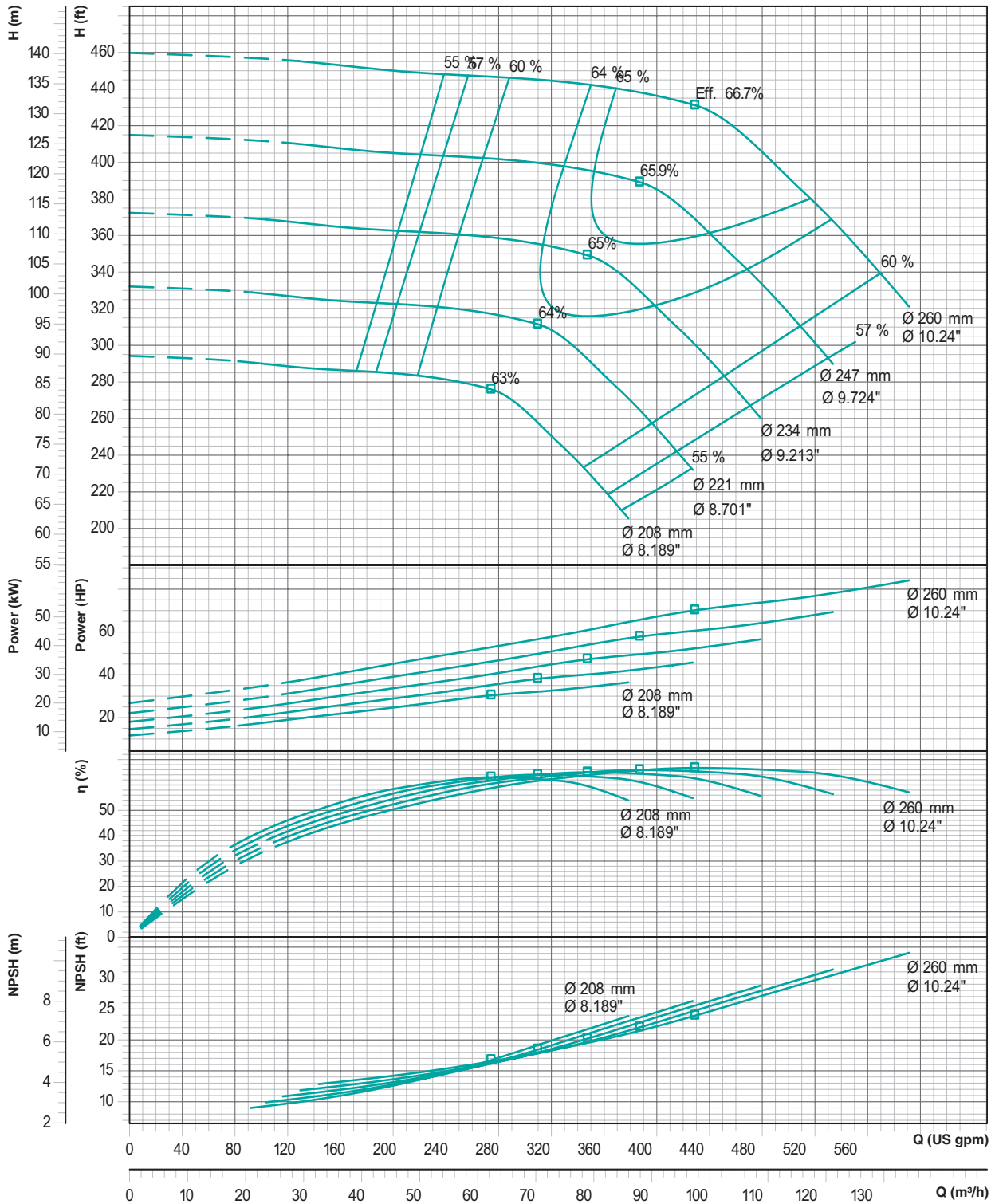

Performance curve tolerances are as per HI : 14.6 / ISO: 9906, Grade 2B

The Company reserves the right to modify the technical specifications and illustrations without prior notice.

PERFORMANCE CURVES

Model : **TEH-50-315**

Speed : **1750 rpm**

Suc x Del (in mm) : **65 x 50**

Max. Impeller Ø : **323mm**

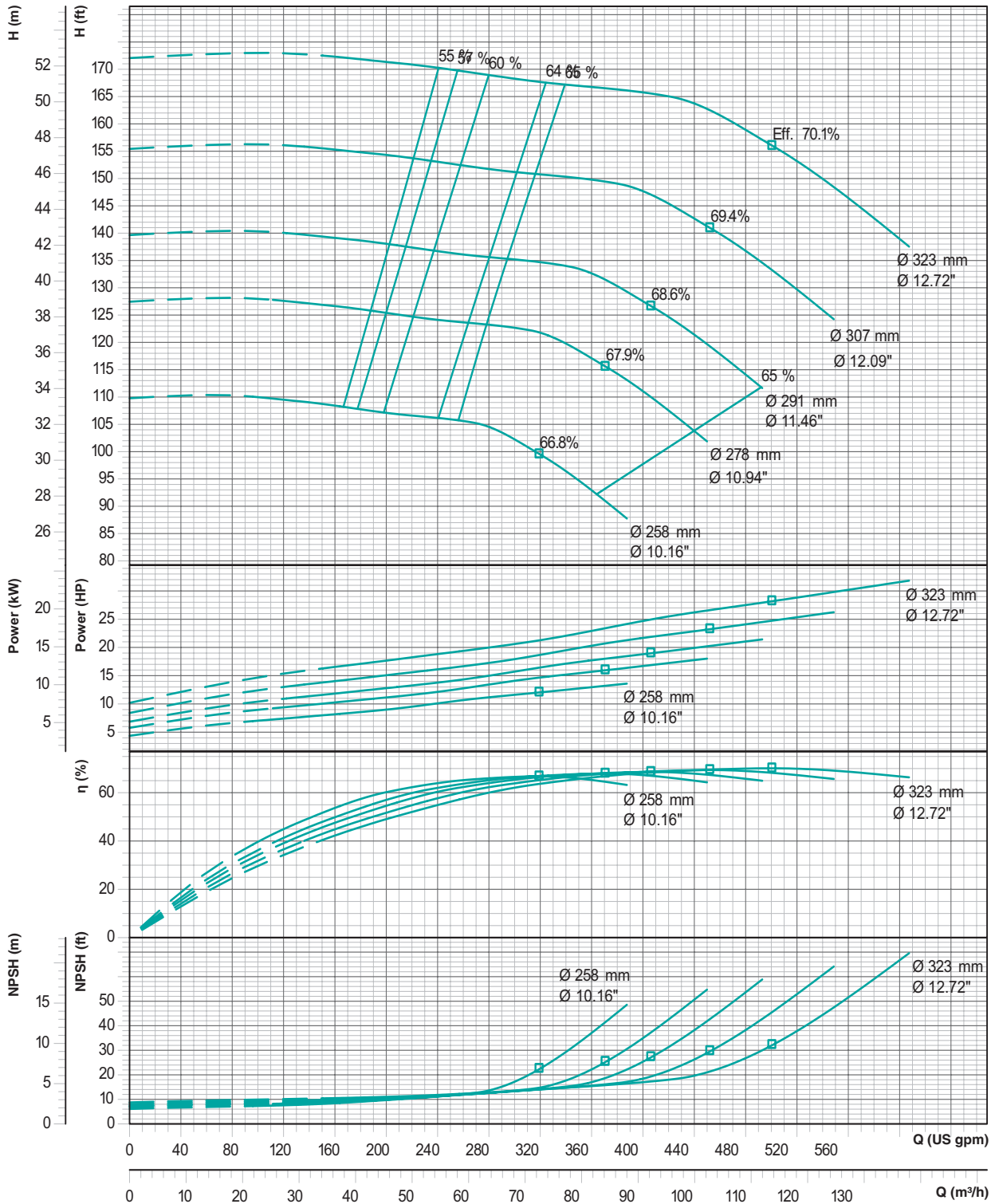

Performance curve tolerances are as per HI : 14.6 / ISO: 9906, Grade 2B

The Company reserves the right to modify the technical specifications and illustrations without prior notice.

PERFORMANCE CURVES

Model : **TEH-65-125**

Speed : **1750 rpm**

Suc x Del (in mm) : **80 x 65**

Max. Impeller Ø : **148mm**

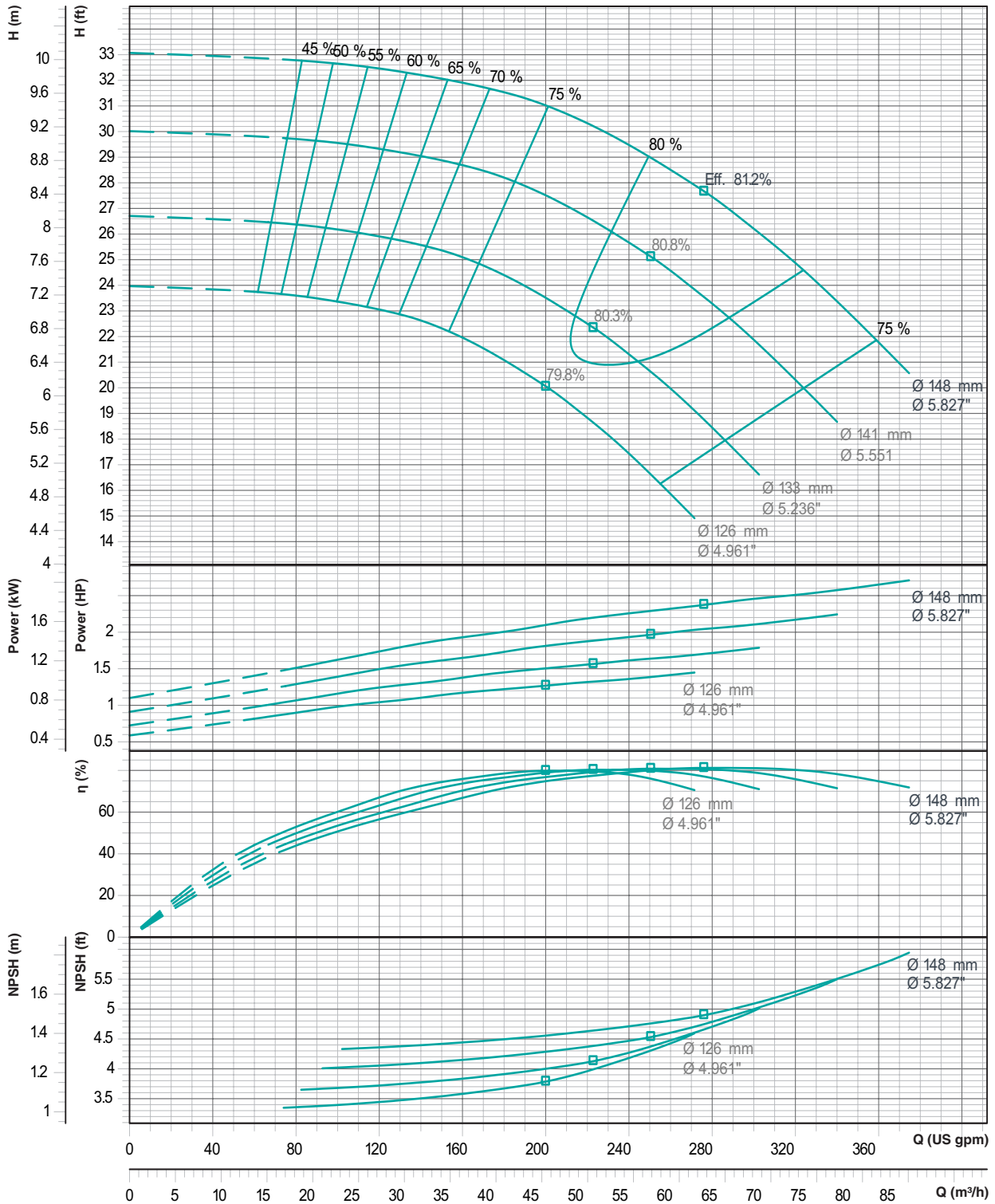

Performance curve tolerances are as per HI : 14.6 / ISO: 9906, Grade 2B

The Company reserves the right to modify the technical specifications and illustrations without prior notice.

PERFORMANCE CURVES

Model : **TEH-65-125**

Speed : **3500 rpm**

Suc x Del (in mm) : **80 x 65**

Max. Impeller Ø : **148mm**

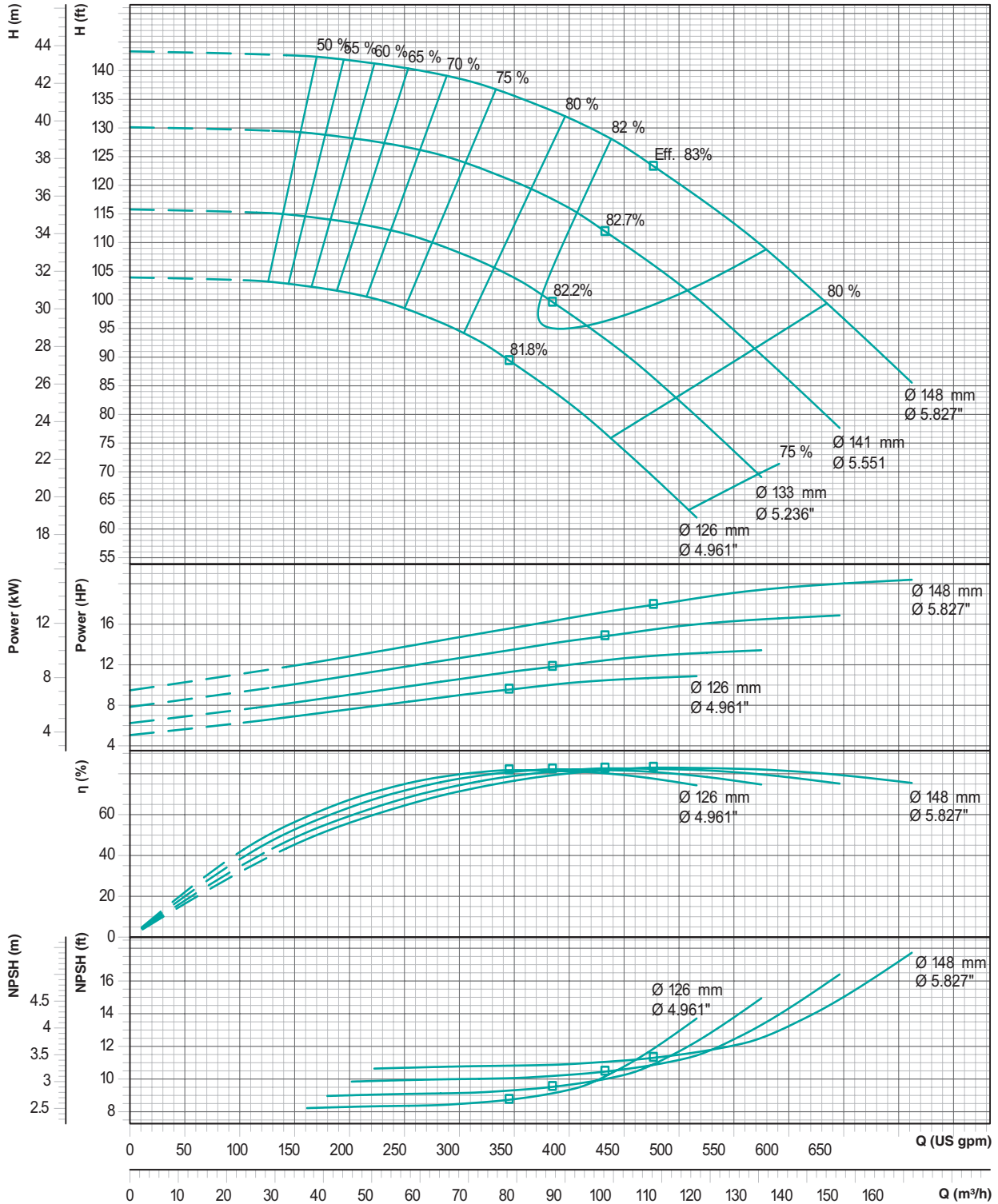

Performance curve tolerances are as per HI : 14.6 / ISO: 9906, Grade 2B

The Company reserves the right to modify the technical specifications and illustrations without prior notice.

PERFORMANCE CURVES

Model : **TEH-65-160**

Speed : **1750 rpm**

Suc x Del (in mm) : **80 x 65**

Max. Impeller Ø : **174mm**

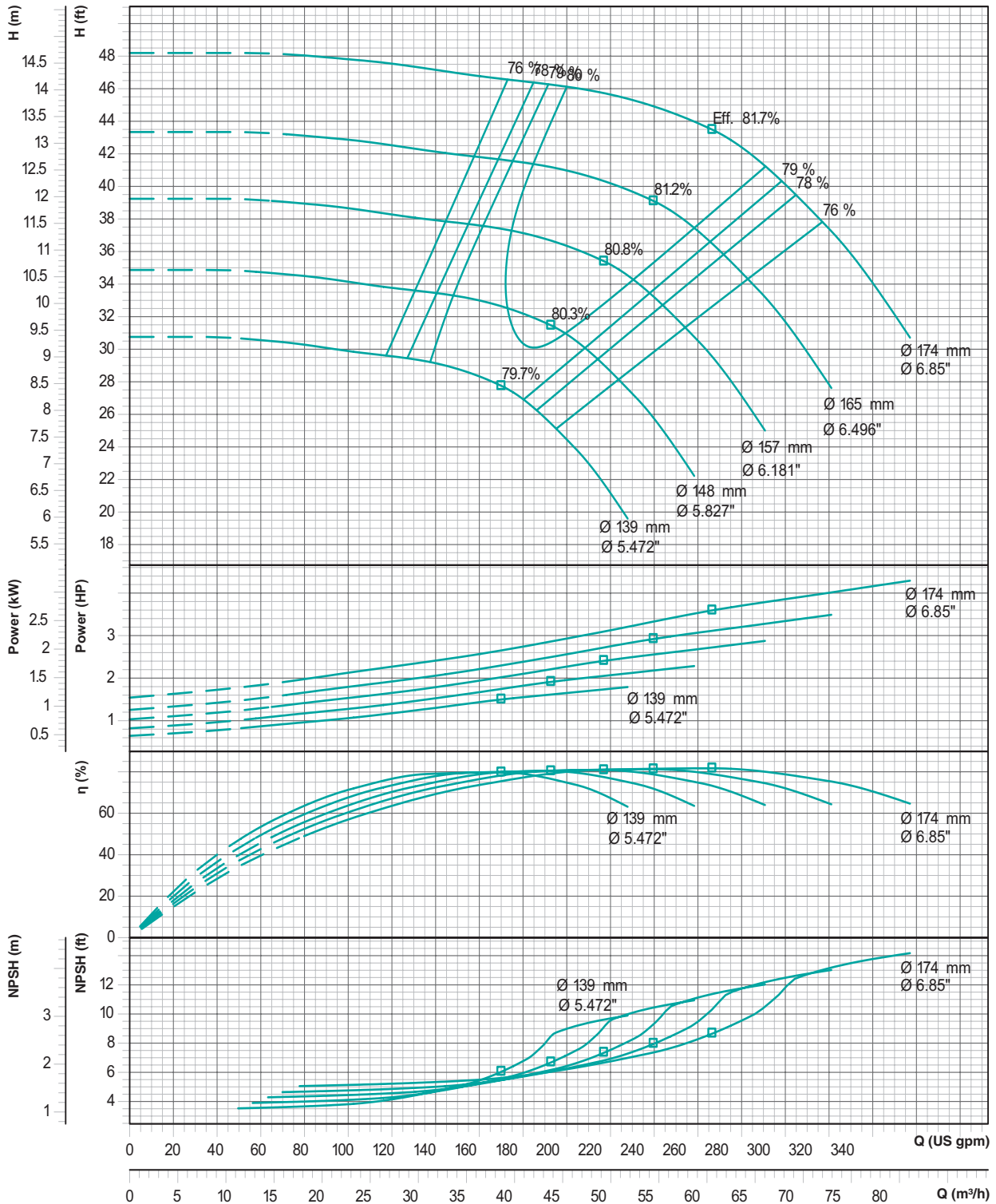

Performance curve tolerances are as per HI : 14.6 / ISO: 9906, Grade 2B

The Company reserves the right to modify the technical specifications and illustrations without prior notice.

PERFORMANCE CURVES

Model : **TEH-65-160**

Speed : **3500 rpm**

Suc x Del (in mm) : **80 x 65**

Max. Impeller Ø : **174mm**

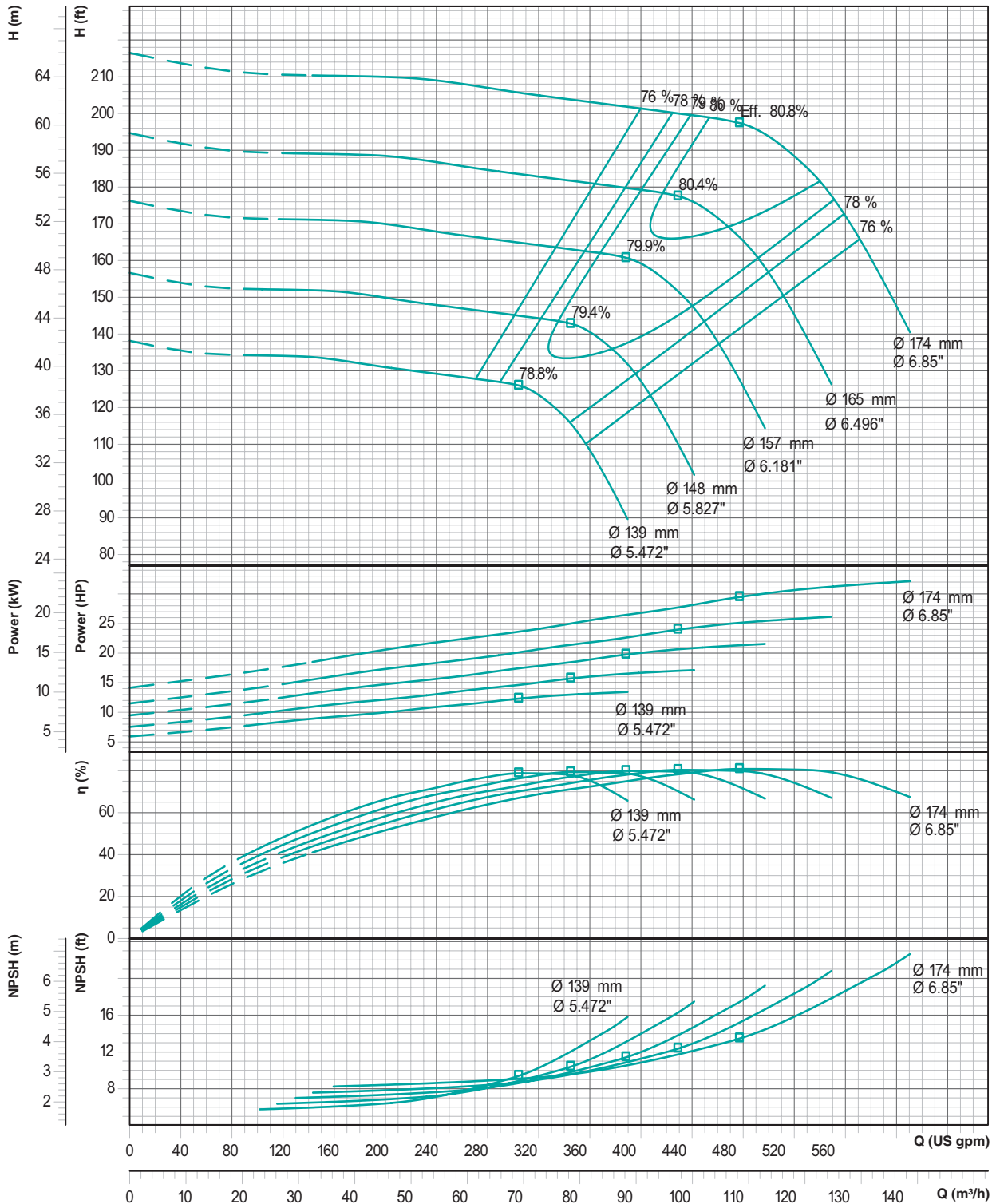

Performance curve tolerances are as per HI : 14.6 / ISO: 9906, Grade 2B

The Company reserves the right to modify the technical specifications and illustrations without prior notice.

PERFORMANCE CURVES

Model : **TEH-65-200**

Speed : **1750 rpm**

Suc x Del (in mm) : **80 x 65**

Max. Impeller Ø : **219mm**

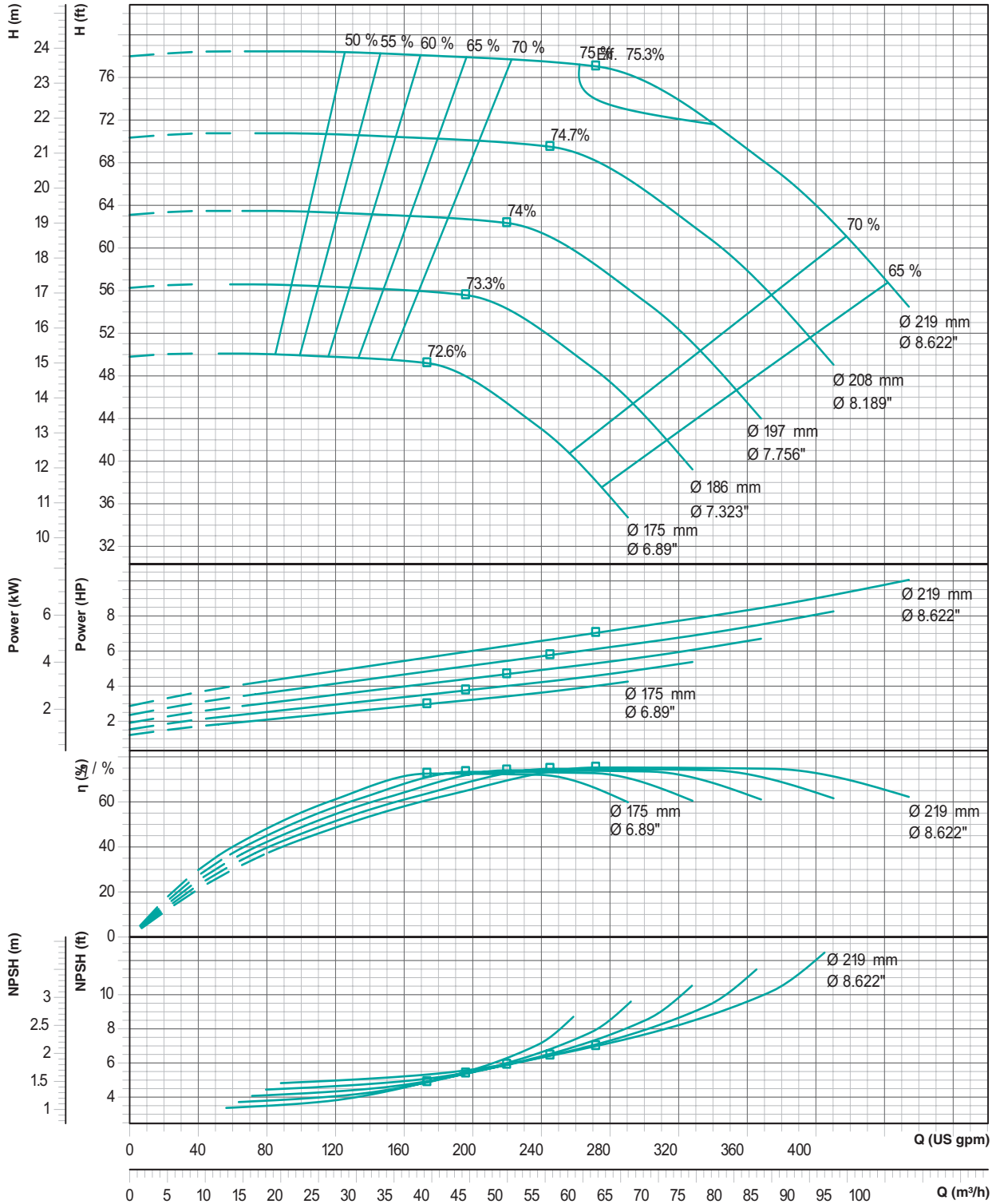

Performance curve tolerances are as per HI : 14.6 / ISO: 9906, Grade 2B

The Company reserves the right to modify the technical specifications and illustrations without prior notice.

PERFORMANCE CURVES

Model : **TEH-65-200**

Speed : **3500 rpm**

Suc x Del (in mm) : **80 x 65**

Max. Impeller Ø : **219mm**

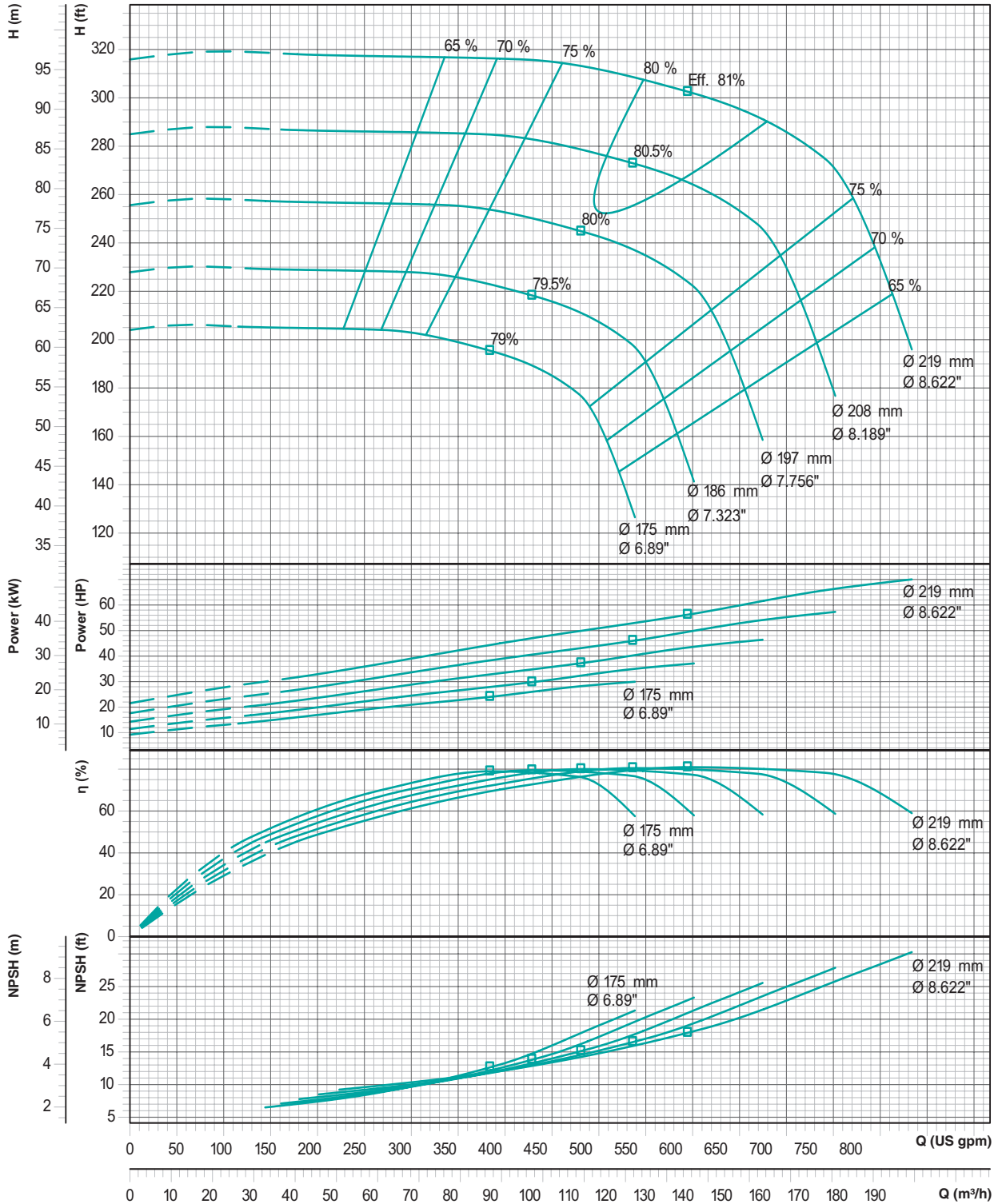

Performance curve tolerances are as per HI : 14.6 / ISO: 9906, Grade 2B

The Company reserves the right to modify the technical specifications and illustrations without prior notice.

PERFORMANCE CURVES

Model : **TEH-65-250 (EW34)**

Speed : **1750 rpm**

Suc x Del (in mm) : **80 x 65**

Max. Impeller Ø : **264mm**

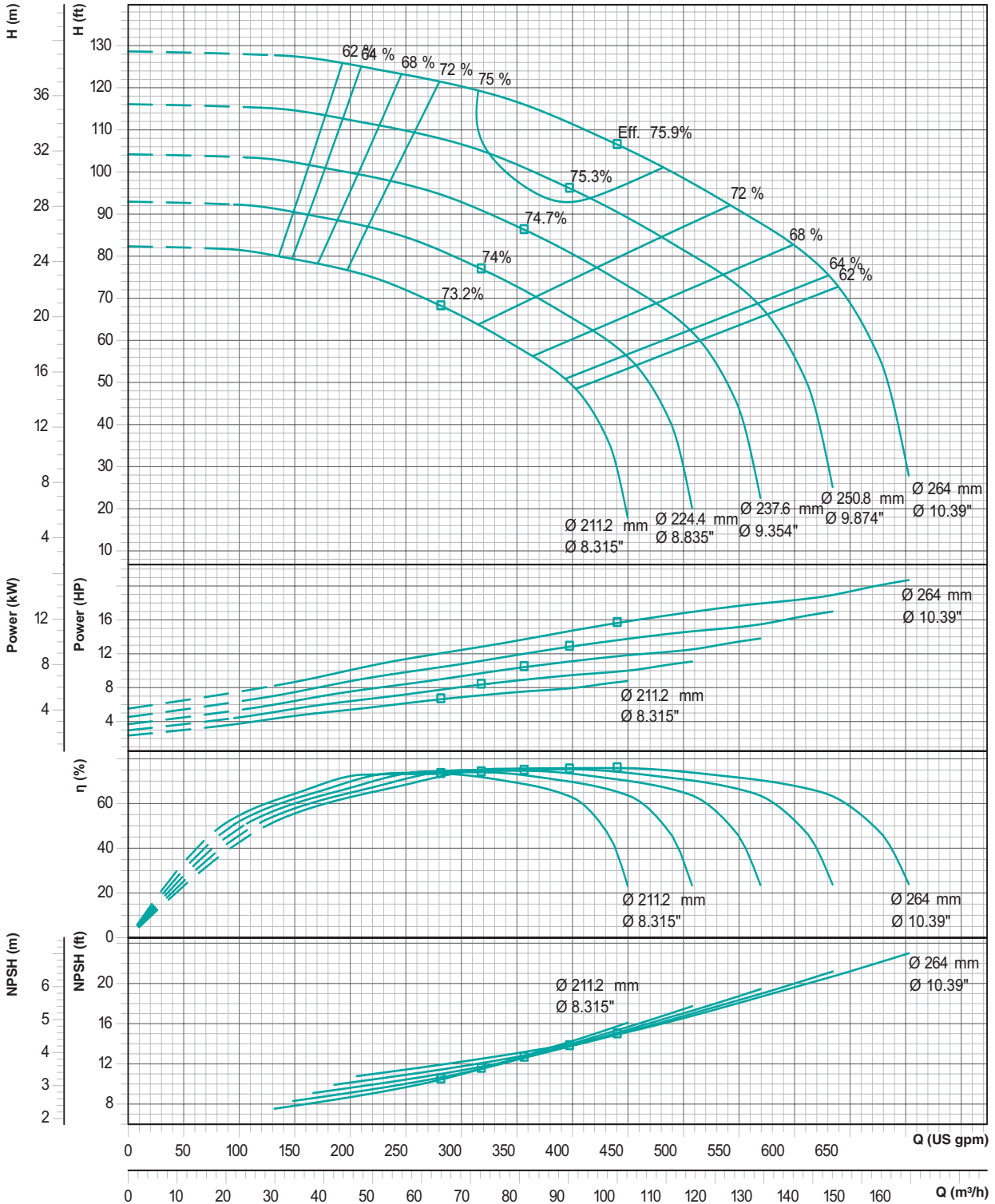

Performance curve tolerances are as per HI : 14.6 / ISO: 9906, Grade 2B

The Company reserves the right to modify the technical specifications and illustrations without prior notice.

PERFORMANCE CURVES

Model : **TEH-65-250 (EW34)**

Speed : **3500 rpm**

Suc x Del (in mm) : **80 x 65**

Max. Impeller Ø : **264mm**

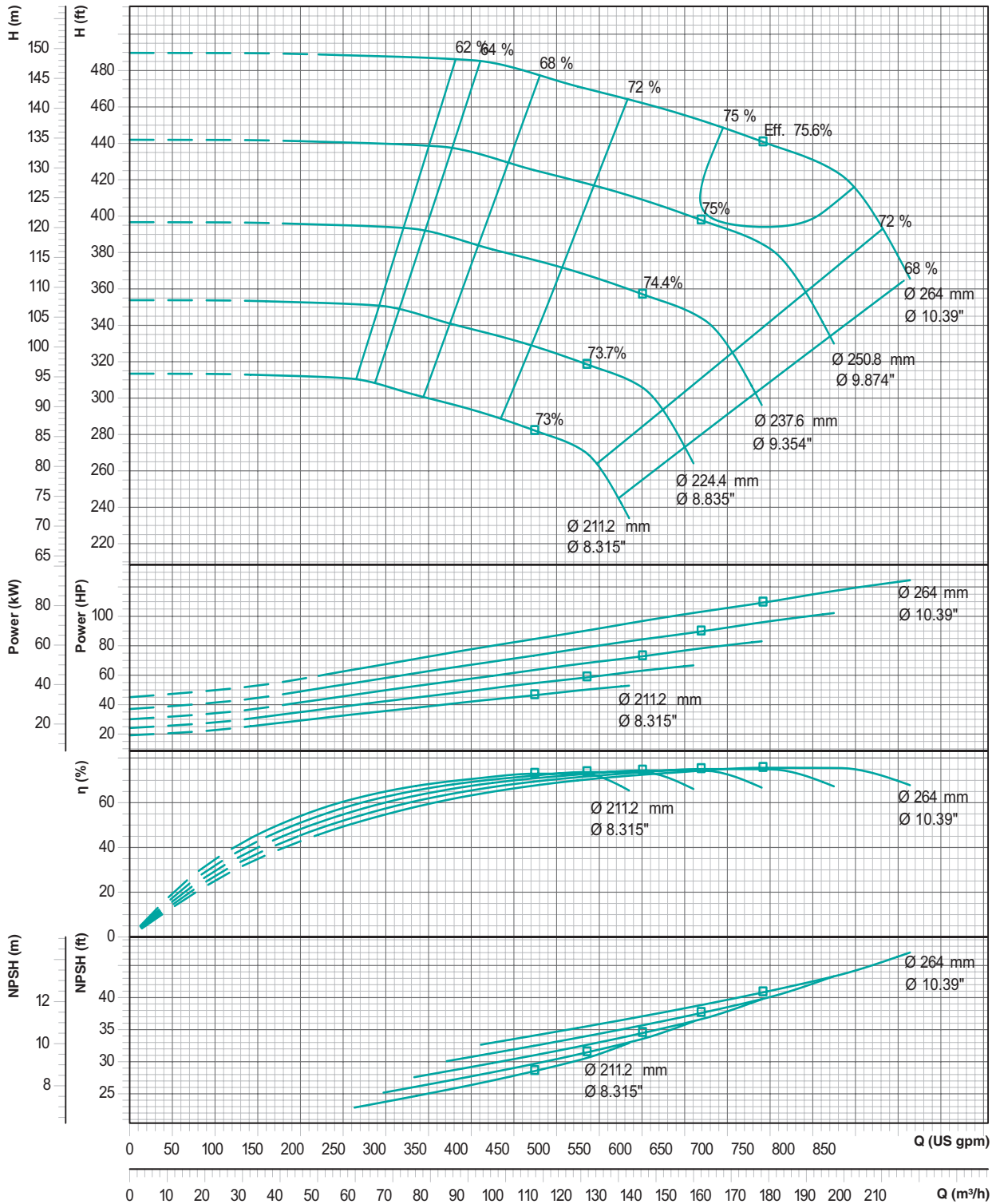

Performance curve tolerances are as per HI : 14.6 / ISO: 9906, Grade 2B

The Company reserves the right to modify the technical specifications and illustrations without prior notice.

PERFORMANCE CURVES

Model : **TEH-65-250**

Speed : **1750 rpm**

Suc x Del (in mm) : **80 x 65**

Max. Impeller Ø : **260mm**

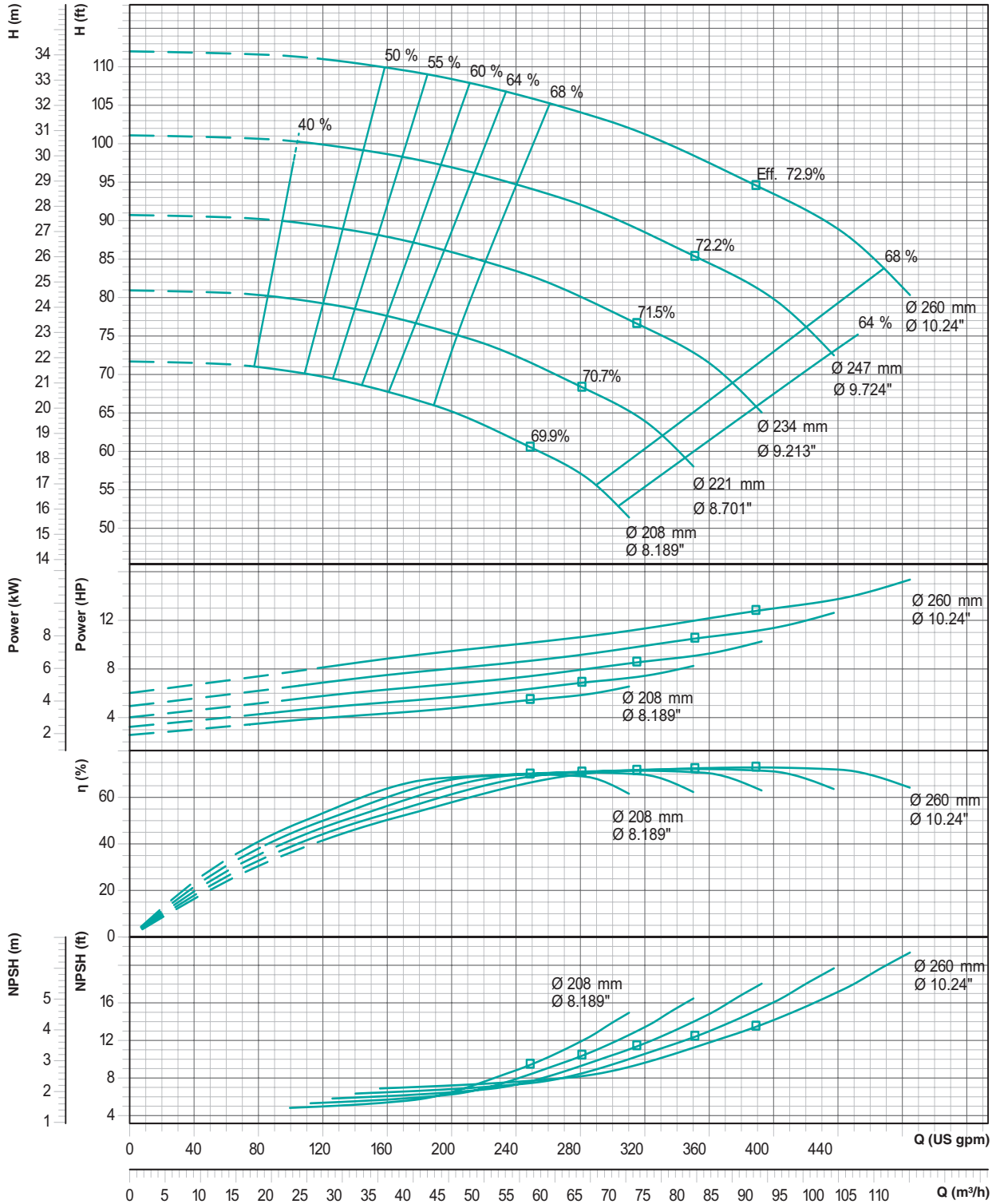

Performance curve tolerances are as per HI : 14.6 / ISO: 9906, Grade 2B

The Company reserves the right to modify the technical specifications and illustrations without prior notice.

PERFORMANCE CURVES

Model : **TEH-65-250**

Speed : **3500 rpm**

Suc x Del (in mm) : **80 x 65**

Max. Impeller Ø : **260mm**

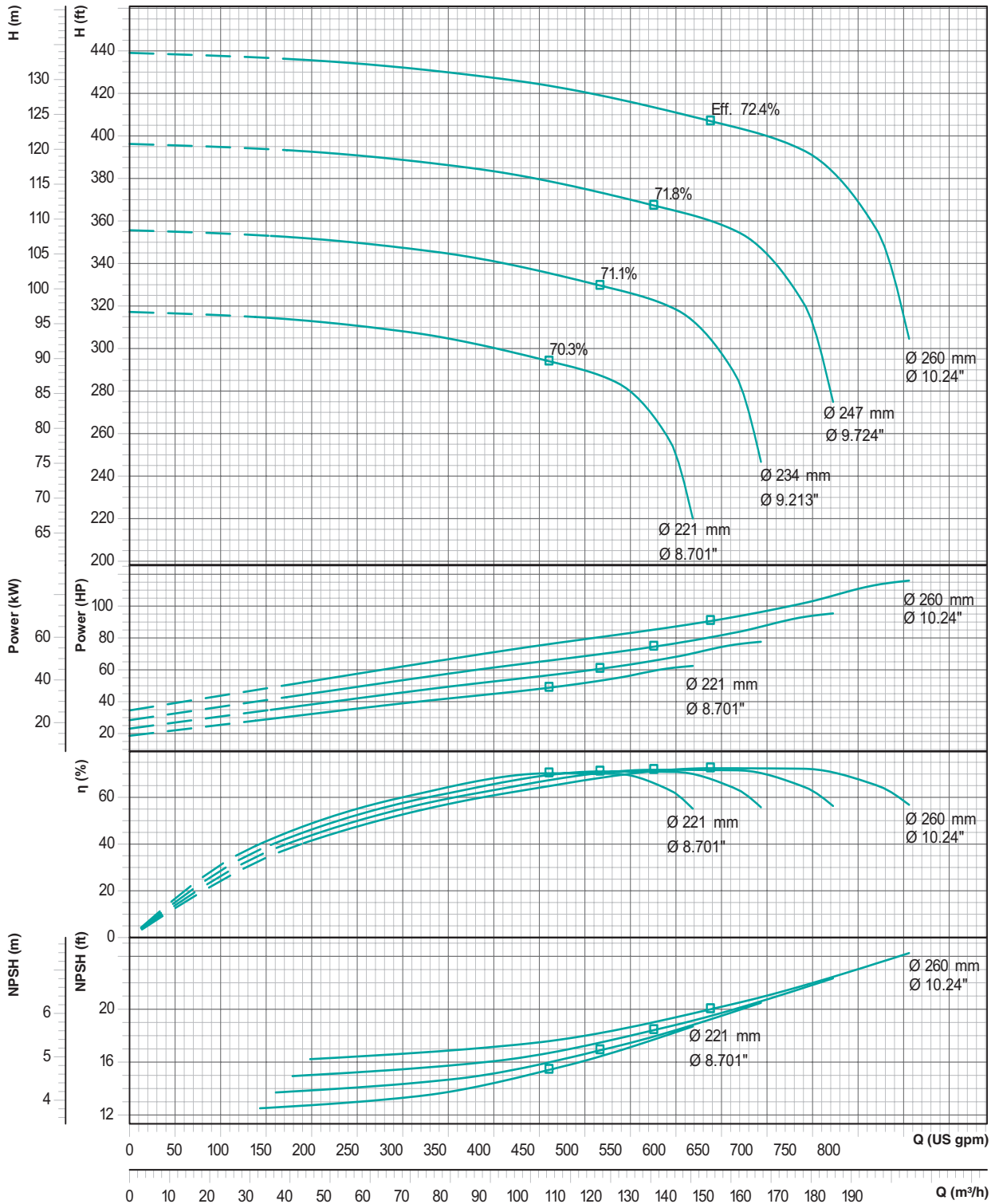

Performance curve tolerances are as per HI : 14.6 / ISO: 9906, Grade 2B

The Company reserves the right to modify the technical specifications and illustrations without prior notice.

PERFORMANCE CURVES

Model : **TEH-65-315**

Speed : **1750 rpm**

Suc x Del (in mm) : **80 x 65**

Max. Impeller Ø : **320mm**

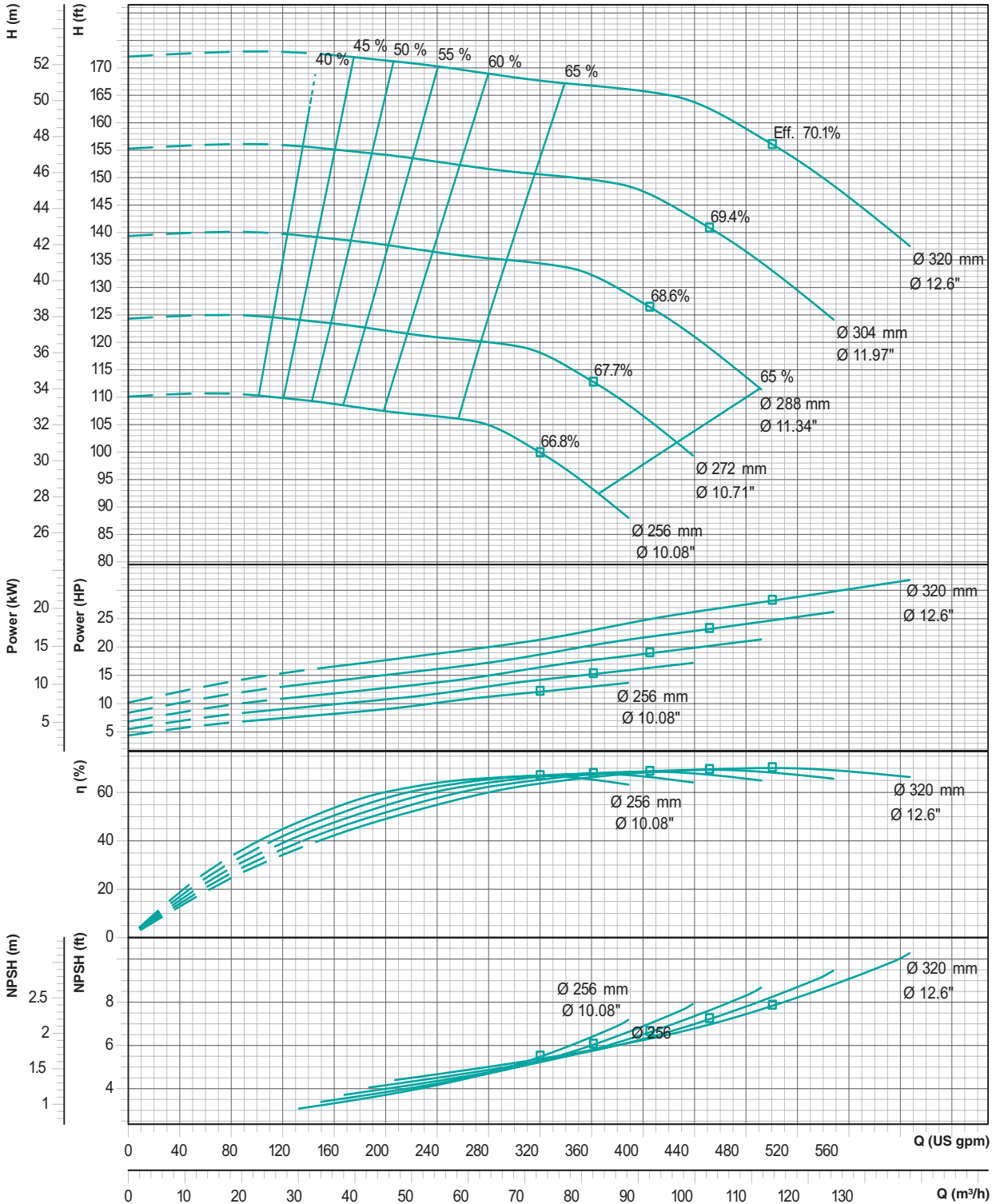

Performance curve tolerances are as per HI : 14.6 / ISO: 9906, Grade 2B

The Company reserves the right to modify the technical specifications and illustrations without prior notice.

PERFORMANCE CURVES

Model : **TEH-65-400**

Speed : **1750 rpm**

Suc x Del (in mm) : **100 x 65**

Max. Impeller Ø : **430mm**

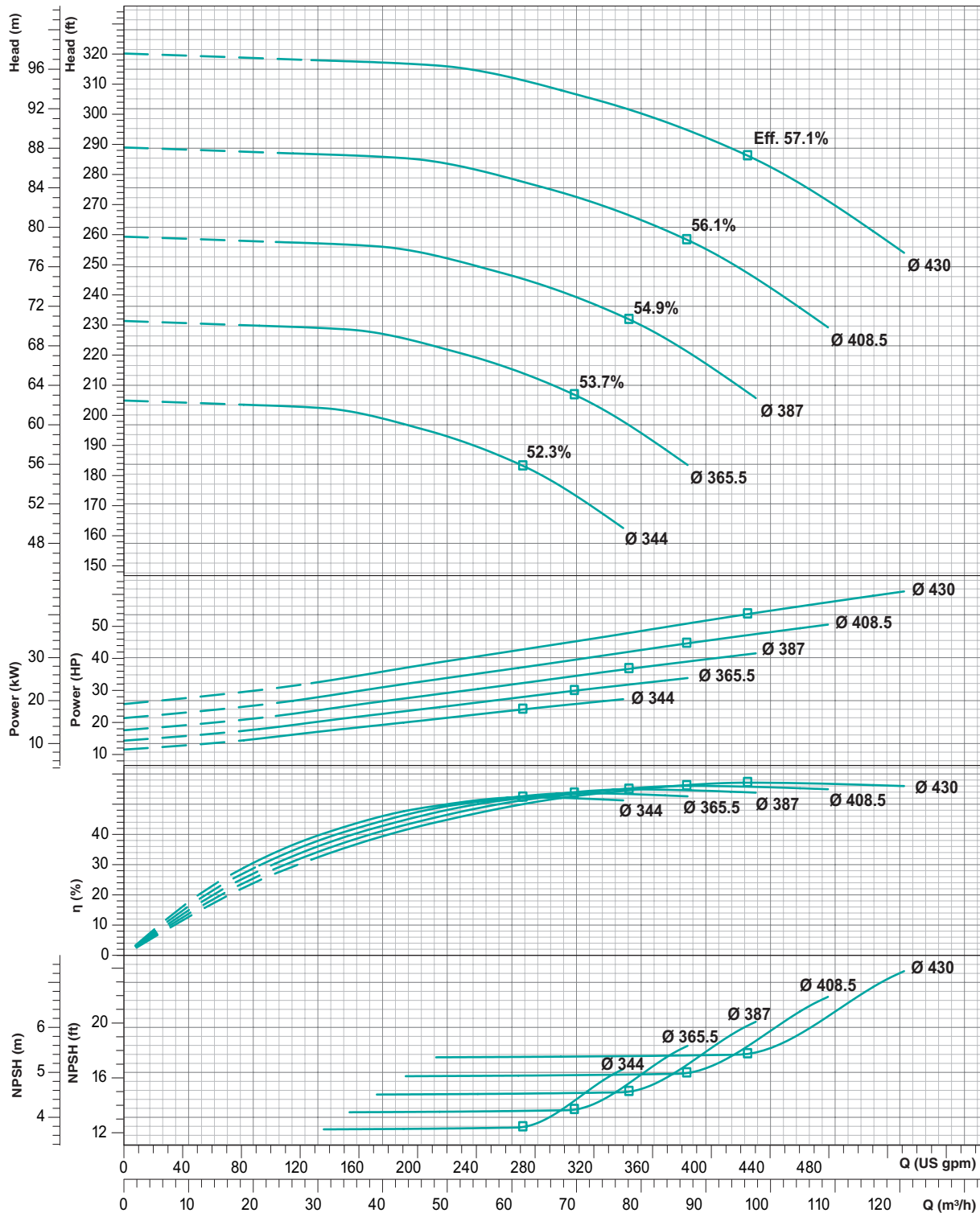

Performance curve tolerances are as per HI : 14.6 / ISO: 9906, Grade 2B

The Company reserves the right to modify the technical specifications and illustrations without prior notice.

PERFORMANCE CURVES

Model : **TEH-80-160**

Speed : **1750 rpm**

Suc x Del (in mm) : **100 x 80**

Max. Impeller Ø : **178mm**

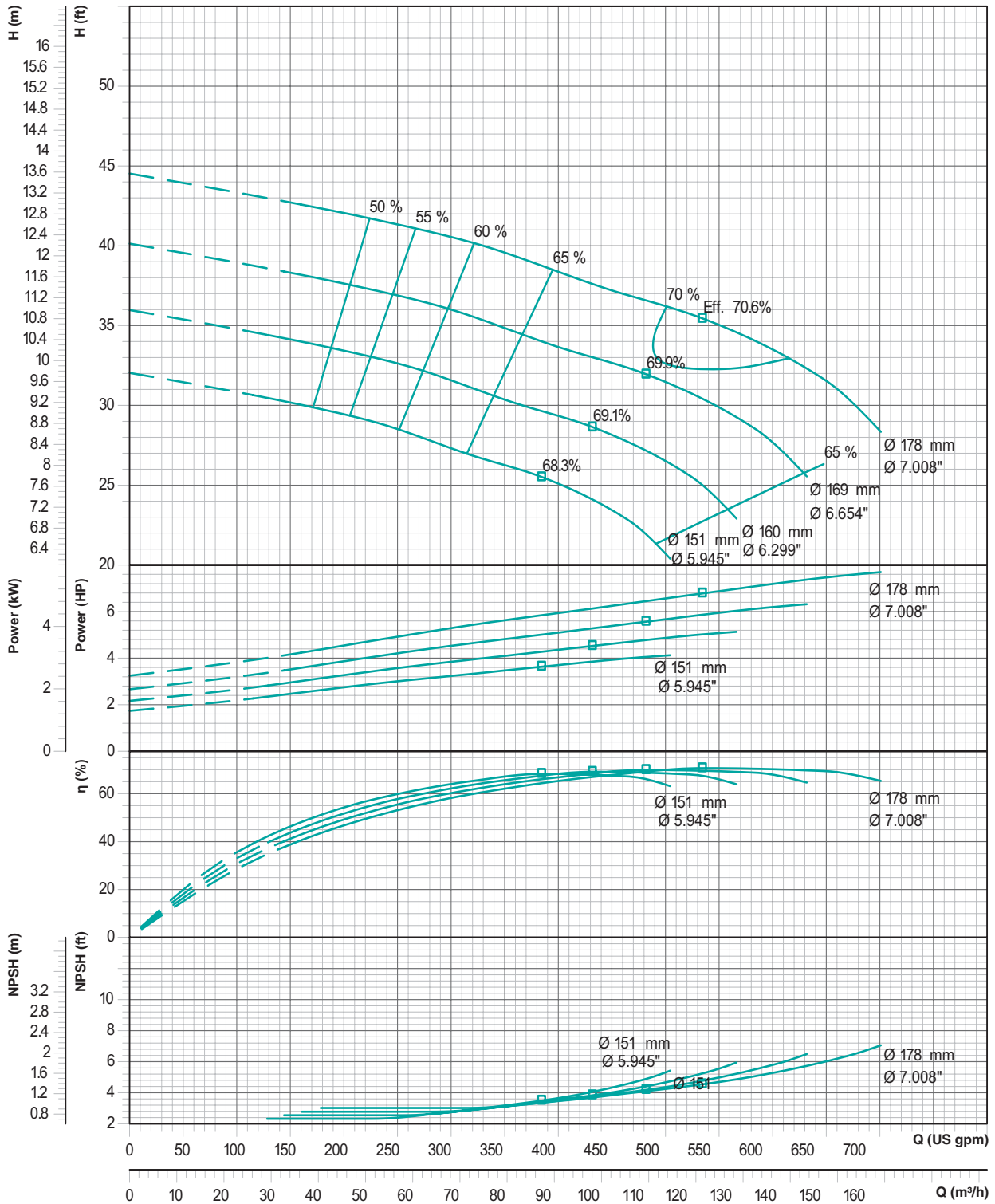

Performance curve tolerances are as per HI : 14.6 / ISO: 9906, Grade 2B

The Company reserves the right to modify the technical specifications and illustrations without prior notice.

PERFORMANCE CURVES

Model : **TEH-80-160**

Speed : **3500 rpm**

Suc x Del (in mm) : **100 x 80**

Max. Impeller Ø : **178mm**

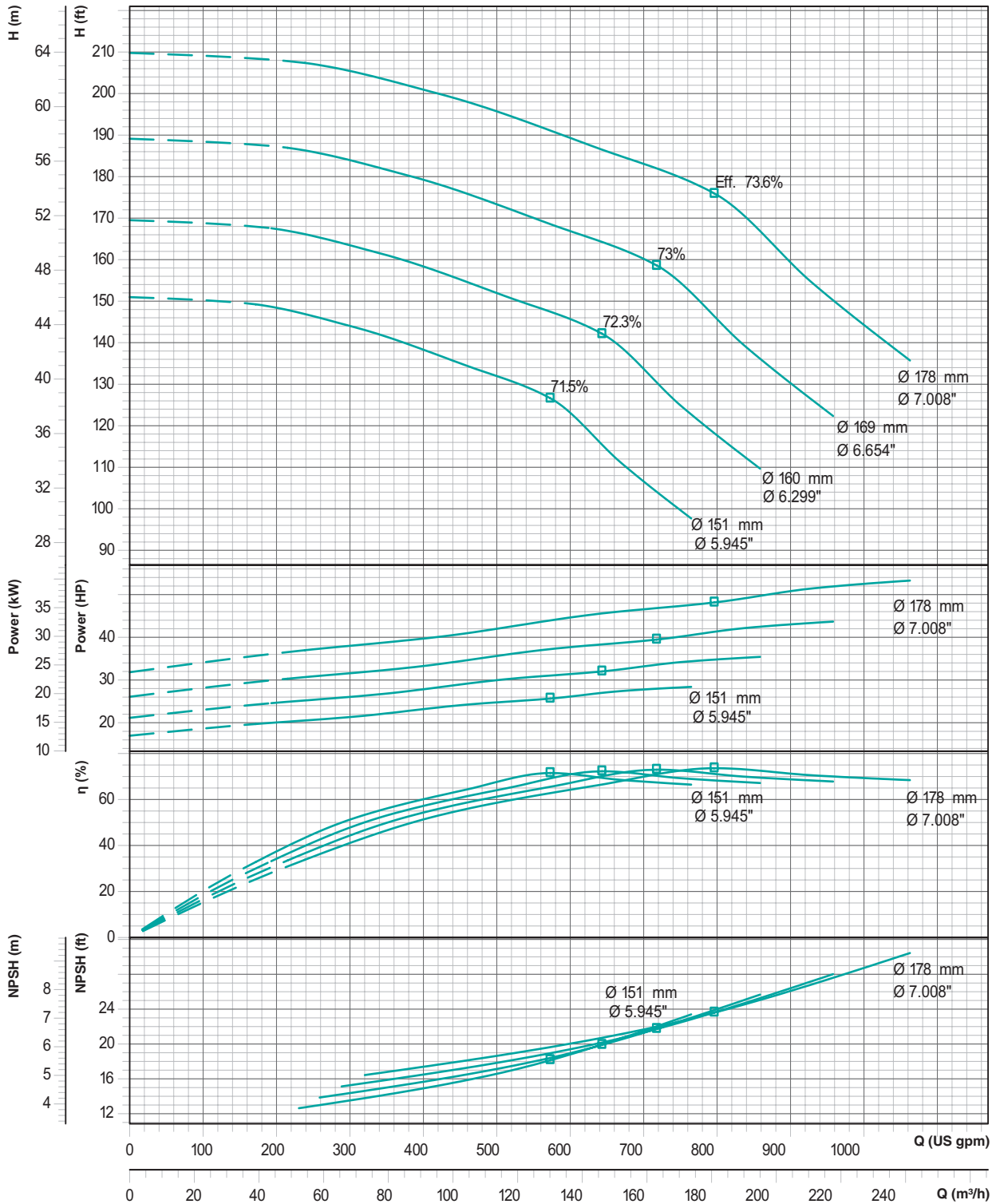

Performance curve tolerances are as per HI : 14.6 / ISO: 9906, Grade 2B

The Company reserves the right to modify the technical specifications and illustrations without prior notice.

PERFORMANCE CURVES

Model : **TEH-80-200**

Speed : **1750 rpm**

Suc x Del (in mm) : **100 x 80**

Max. Impeller Ø : **220mm**

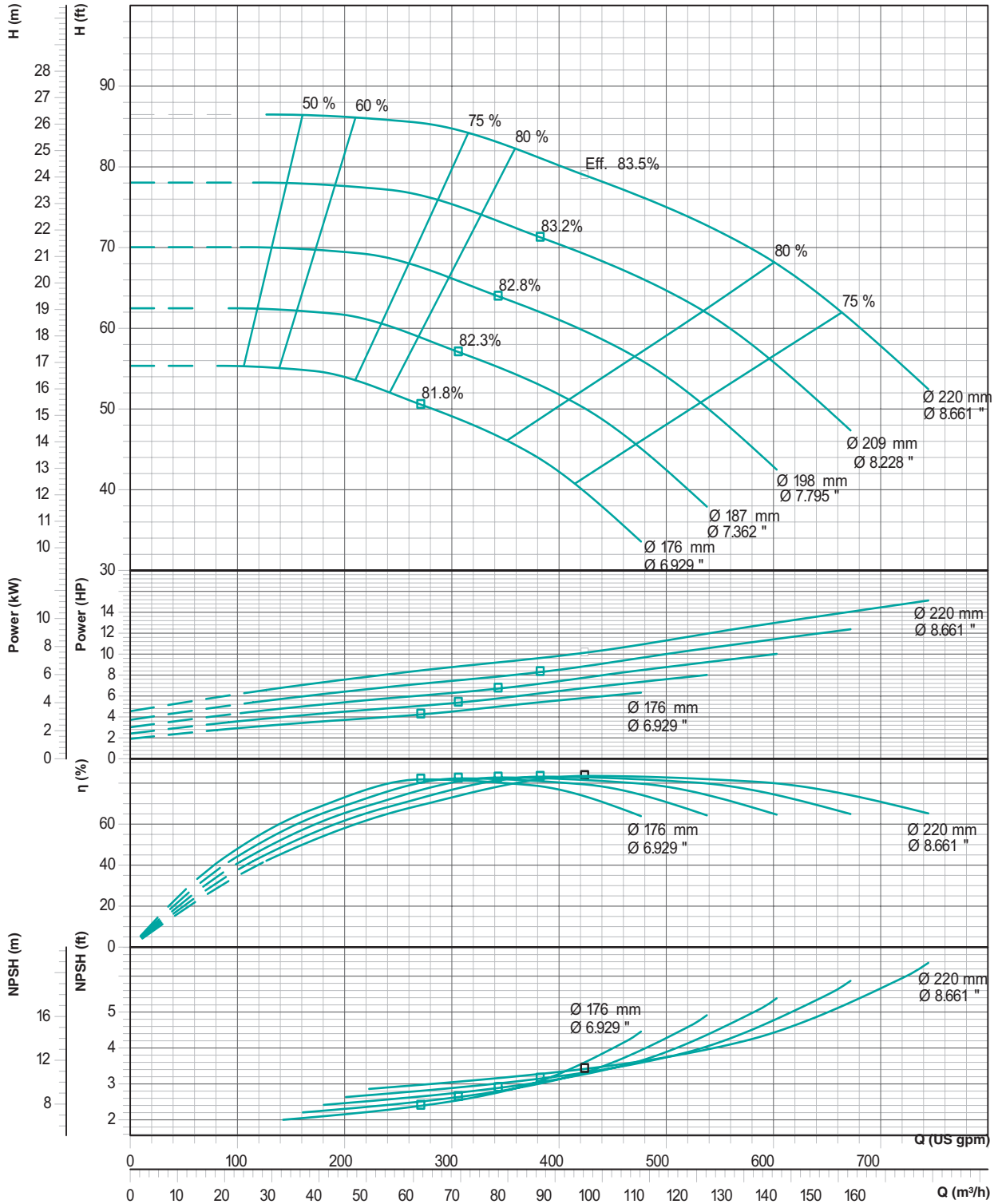

Performance curve tolerances are as per HI : 14.6 / ISO: 9906, Grade 2B

The Company reserves the right to modify the technical specifications and illustrations without prior notice.

PERFORMANCE CURVES

Model : **TEH-80-200**

Speed : **3500 rpm**

Suc x Del (in mm) : **100 x 80**

Max. Impeller Ø : **220mm**

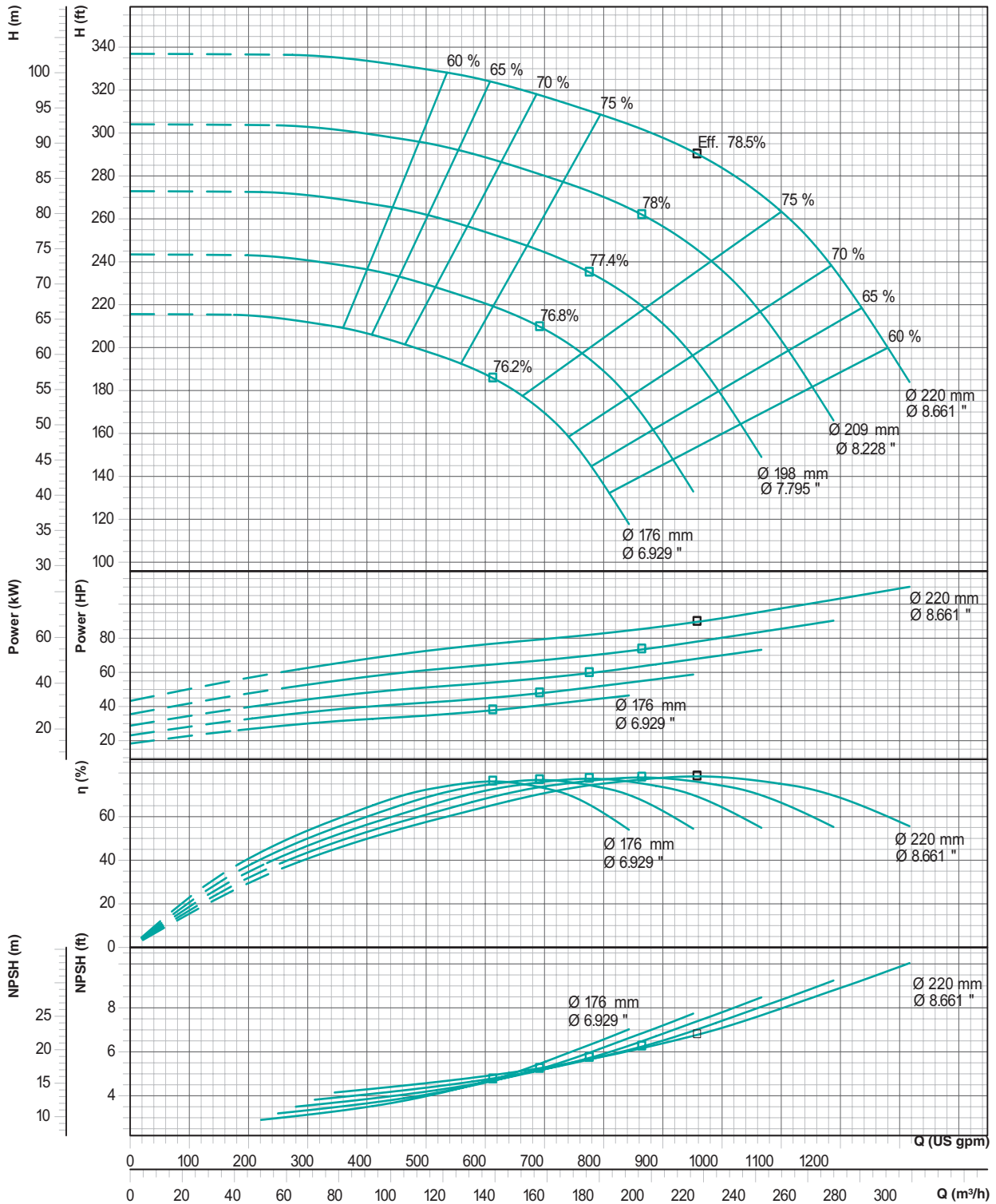

Performance curve tolerances are as per HI : 14.6 / ISO: 9906, Grade 2B

The Company reserves the right to modify the technical specifications and illustrations without prior notice.

PERFORMANCE CURVES

Model : **TEH-80-250 (EW36)**

Speed : **1750 rpm**

Suc x Del (in mm) : **100 x 80**

Max. Impeller Ø : **264mm**

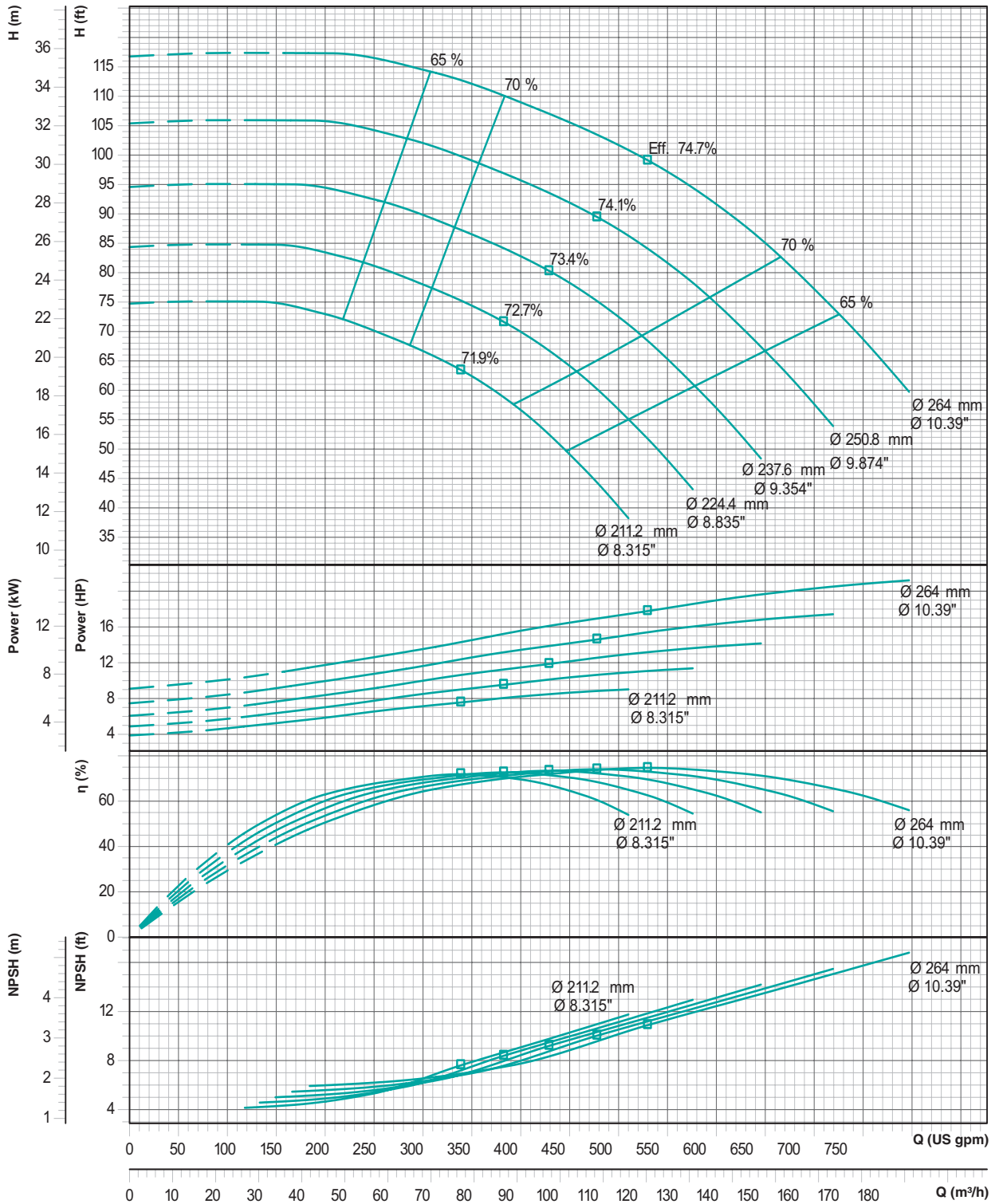

Performance curve tolerances are as per HI : 14.6 / ISO: 9906, Grade 2B

The Company reserves the right to modify the technical specifications and illustrations without prior notice.

PERFORMANCE CURVES

Model : **TEH-80-250 (EW36)**

Speed : **3500 rpm**

Suc x Del (in mm) : **100 x 80**

Max. Impeller Ø : **264mm**

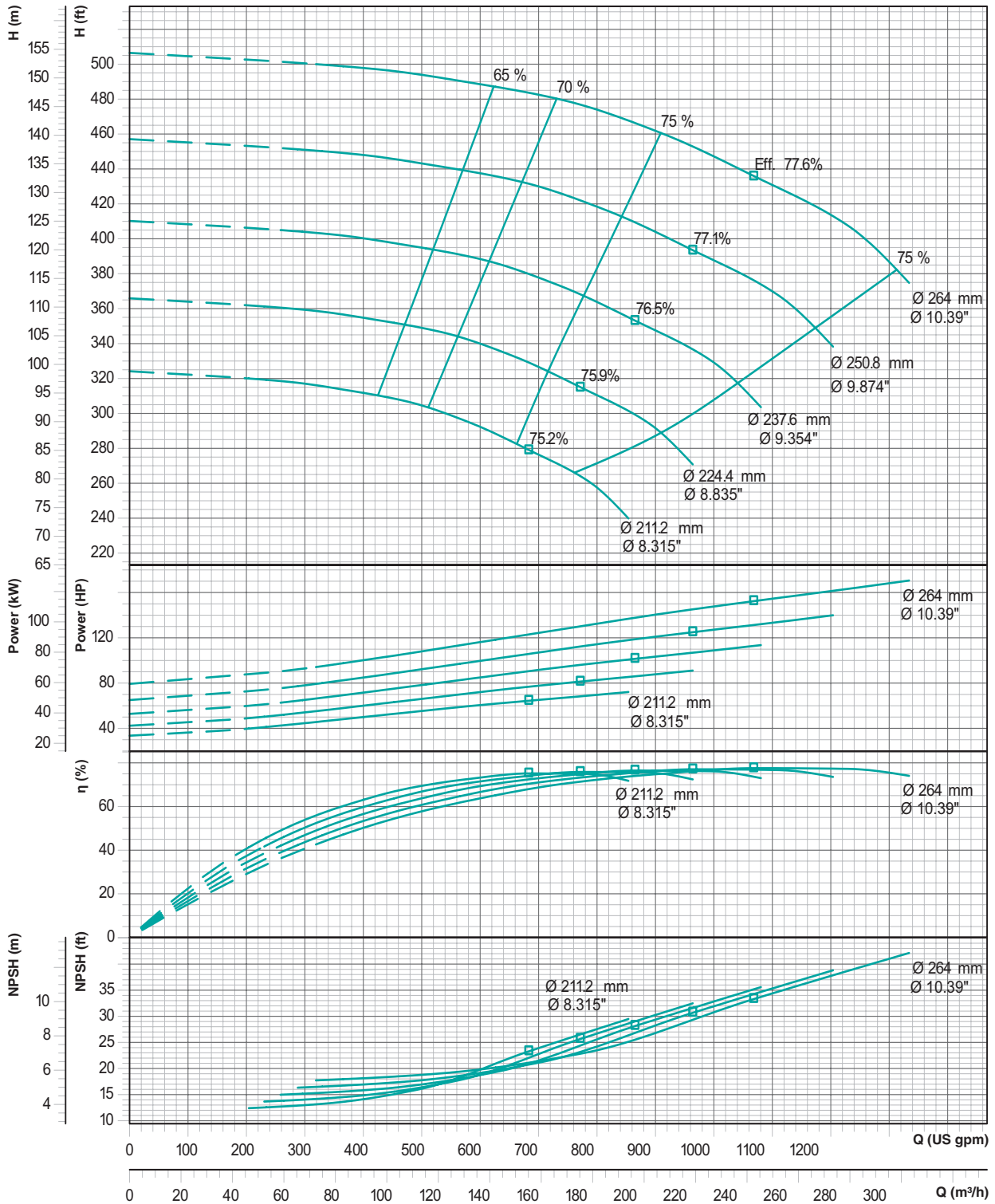

Performance curve tolerances are as per HI : 14.6 / ISO: 9906, Grade 2B

The Company reserves the right to modify the technical specifications and illustrations without prior notice.

PERFORMANCE CURVES

Model : **TEH-80-250**

Speed : **1750 rpm**

Suc x Del (in mm) : **100 x 80**

Max. Impeller Ø : **269mm**

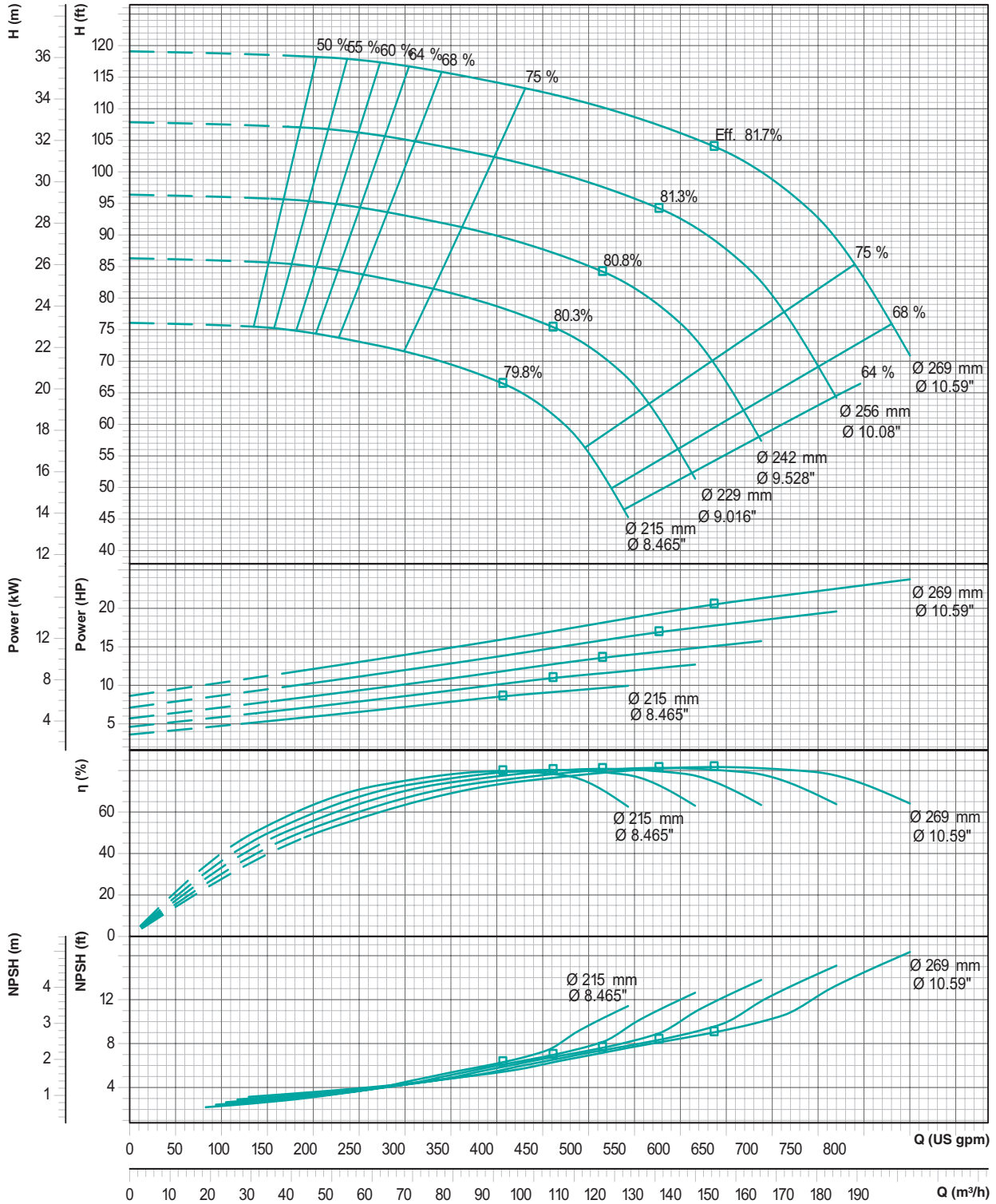

Performance curve tolerances are as per HI : 14.6 / ISO: 9906, Grade 2B

The Company reserves the right to modify the technical specifications and illustrations without prior notice.

PERFORMANCE CURVES

Model : **TEH-80-250**

Speed : **3500 rpm**

Suc x Del (in mm) : **100 x 80**

Max. Impeller Ø : **269mm**

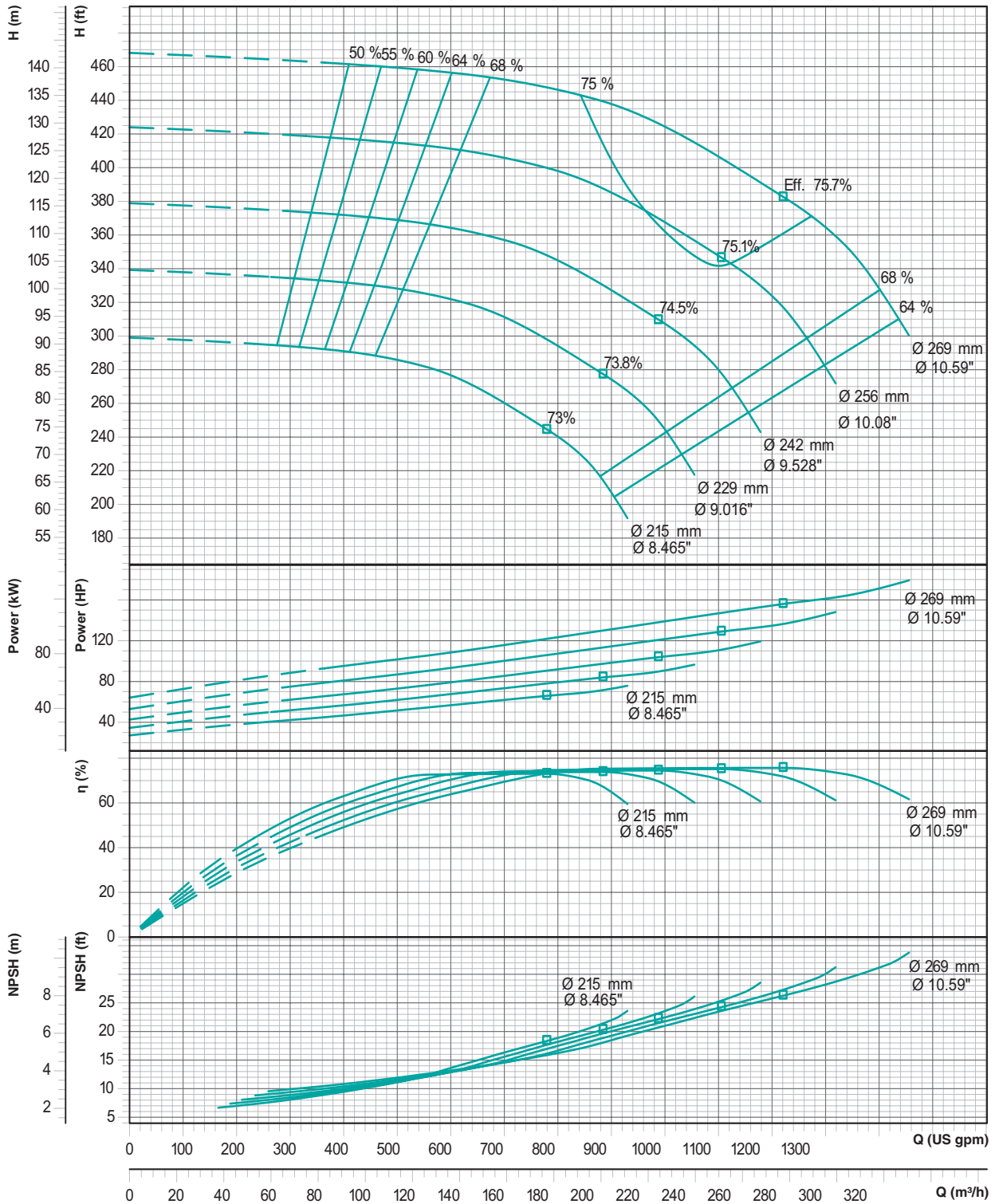

Performance curve tolerances are as per HI : 14.6 / ISO: 9906, Grade 2B

The Company reserves the right to modify the technical specifications and illustrations without prior notice.

PERFORMANCE CURVES

Model : **TEH-80-315**

Speed : **1750 rpm**

Suc x Del (in mm) : **100 x 80**

Max. Impeller Ø : **338mm**

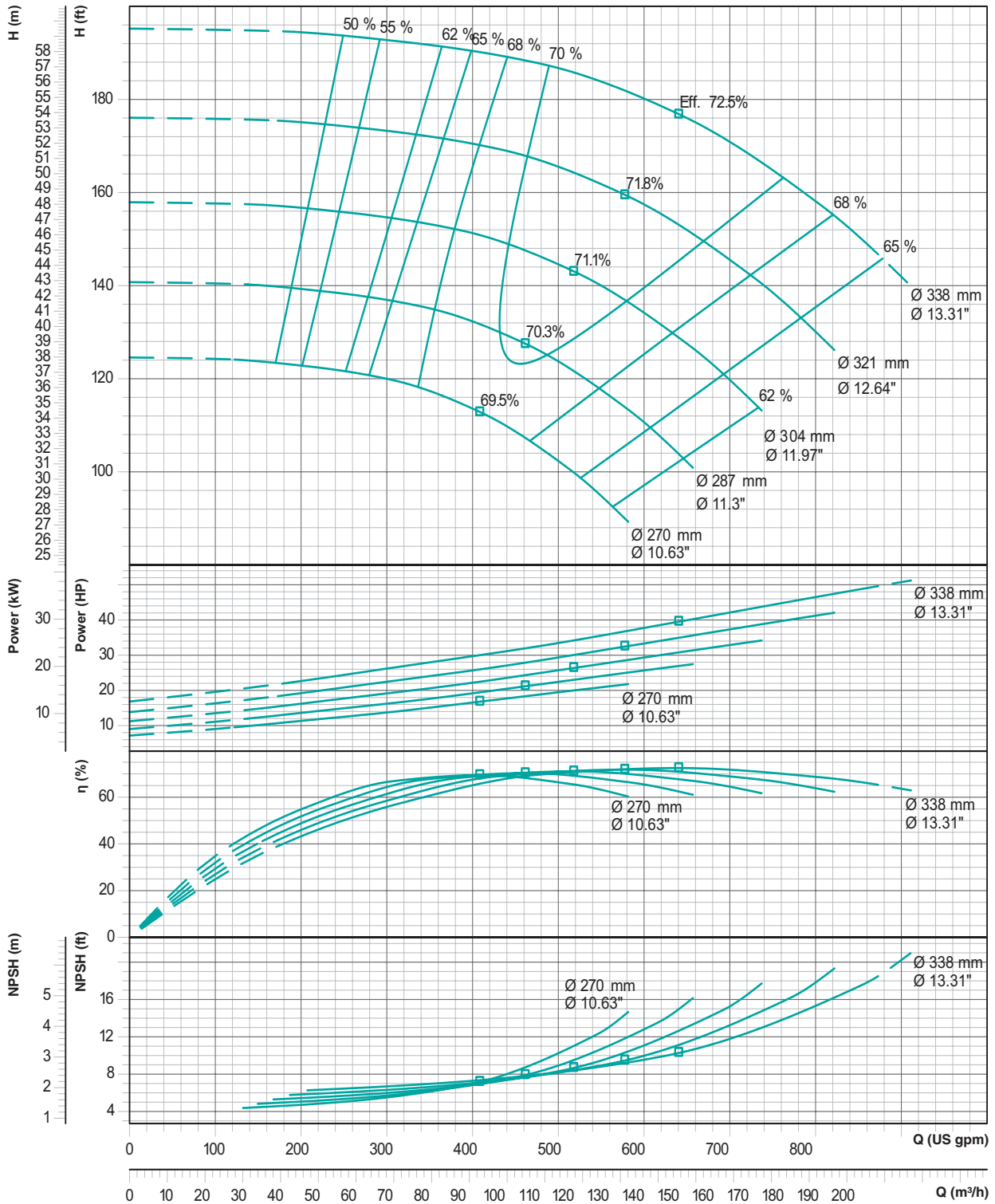

Performance curve tolerances are as per HI : 14.6 / ISO: 9906, Grade 2B

The Company reserves the right to modify the technical specifications and illustrations without prior notice.

PERFORMANCE CURVES

Model : **TEH-80-400**

Speed : **1750 rpm**

Suc x Del (in mm) : **100 x 80**

Max. Impeller Ø : **400mm**

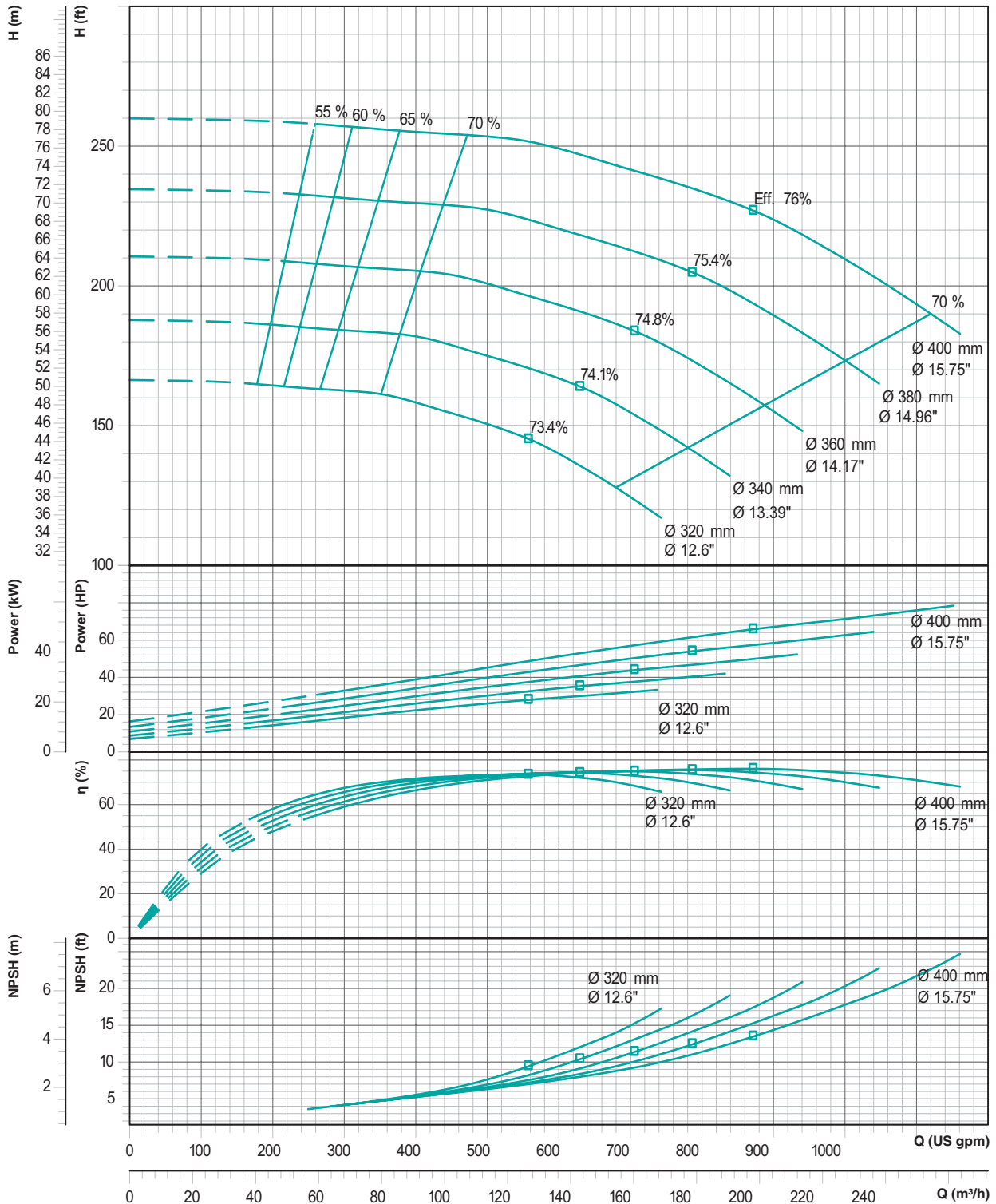

Performance curve tolerances are as per HI : 14.6 / ISO: 9906, Grade 2B

The Company reserves the right to modify the technical specifications and illustrations without prior notice.

PERFORMANCE CURVES

Model : **TEH-80-415**

Speed : **1750 rpm**

Suc x Del (in mm) : **100 x 80**

Max. Impeller Ø : **415mm**

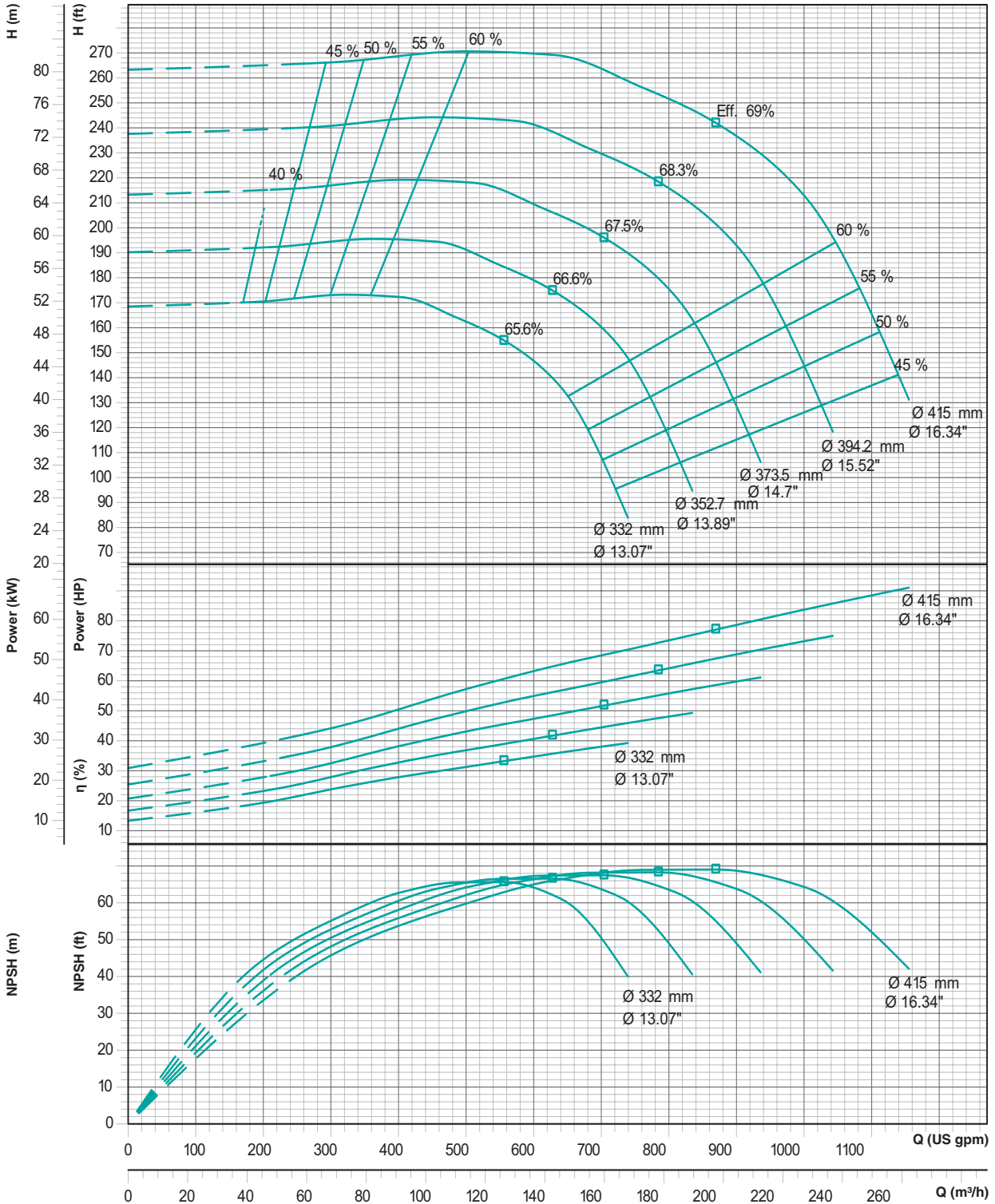

Performance curve tolerances are as per HI : 14.6 / ISO: 9906, Grade 2B

The Company reserves the right to modify the technical specifications and illustrations without prior notice.

PERFORMANCE CURVES

Model : **TEH-100-160**

Speed : **1750 rpm**

Suc x Del (in mm) : **125 x 100**

Max. Impeller Ø : **187mm**

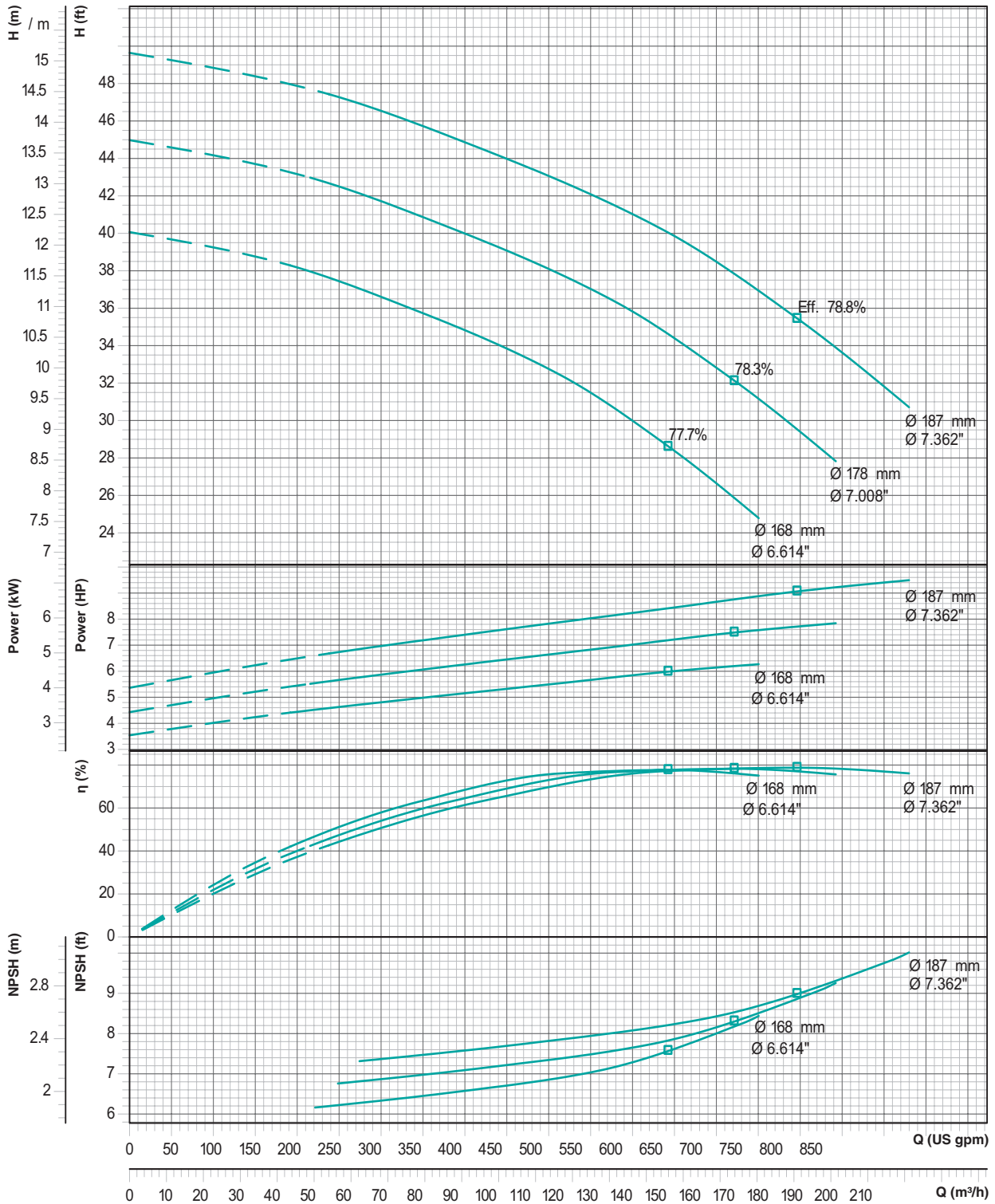

Performance curve tolerances are as per HI : 14.6 / ISO: 9906, Grade 2B

The Company reserves the right to modify the technical specifications and illustrations without prior notice.

PERFORMANCE CURVES

Model : **TEH-100-160**

Speed : **3500 rpm**

Suc x Del (in mm) : **125 x 100**

Max. Impeller Ø : **187mm**

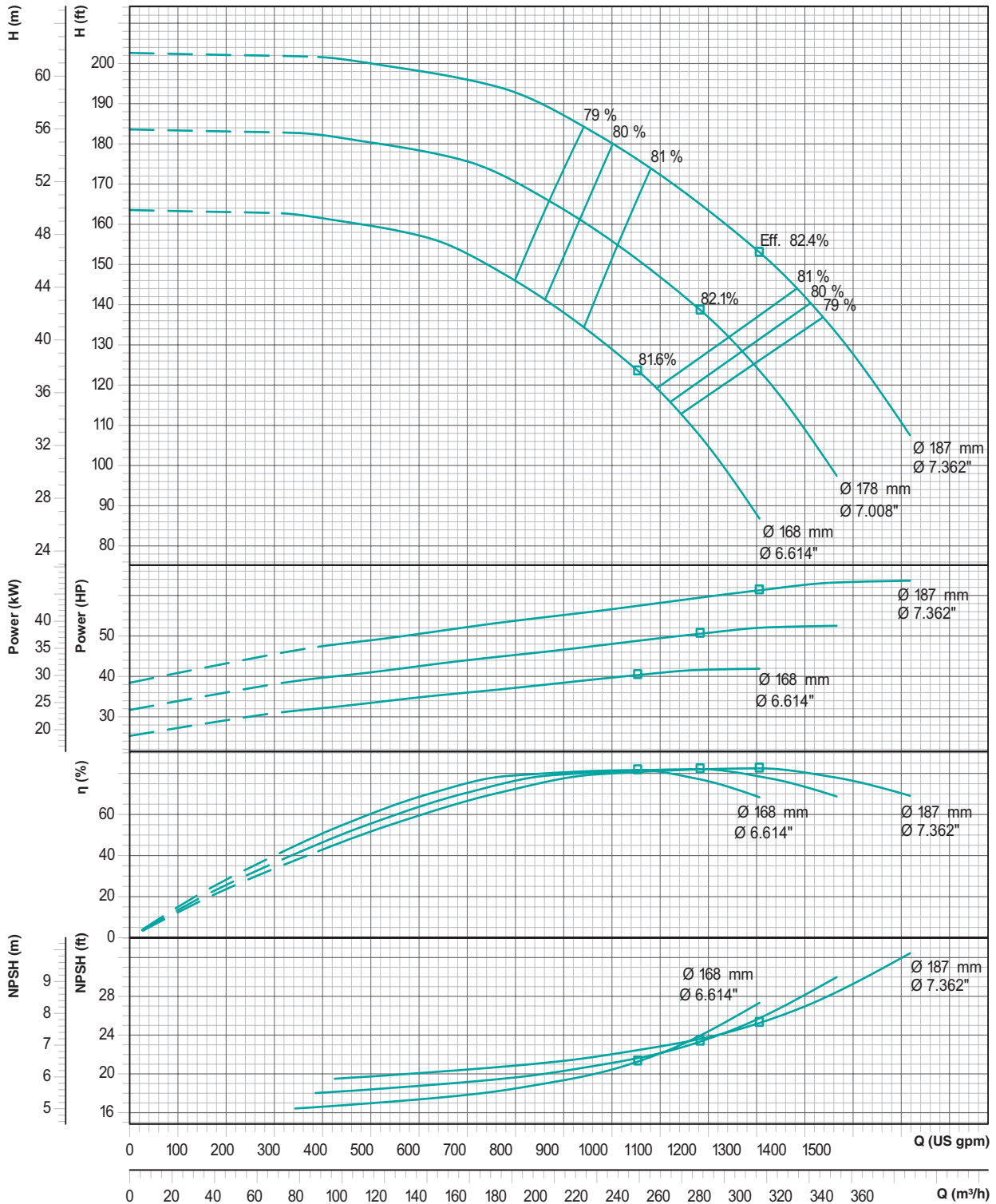

Performance curve tolerances are as per HI : 14.6 / ISO: 9906, Grade 2B

The Company reserves the right to modify the technical specifications and illustrations without prior notice.

PERFORMANCE CURVES

Model : **TEH-100-250 (EW38)**

Speed : **1750 rpm**

Suc x Del (in mm) : **125 x 100**

Max. Impeller Ø : **264mm**

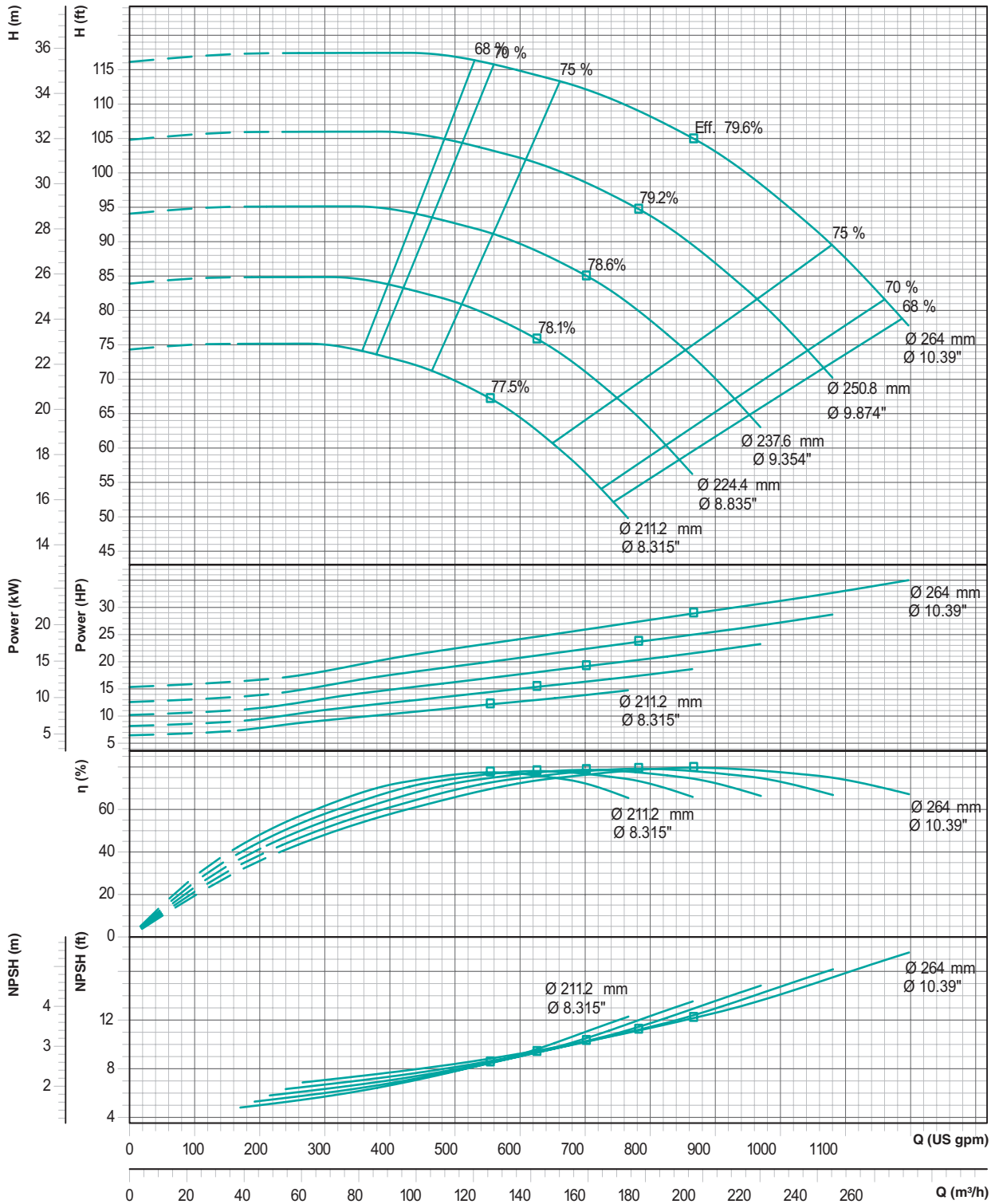

Performance curve tolerances are as per HI : 14.6 / ISO: 9906, Grade 2B

The Company reserves the right to modify the technical specifications and illustrations without prior notice.

PERFORMANCE CURVES

Model : **TEH-100-250 (EW38)**

Speed : **3500 rpm**

Suc x Del (in mm) : **125 x 100**

Max. Impeller Ø : **264mm**

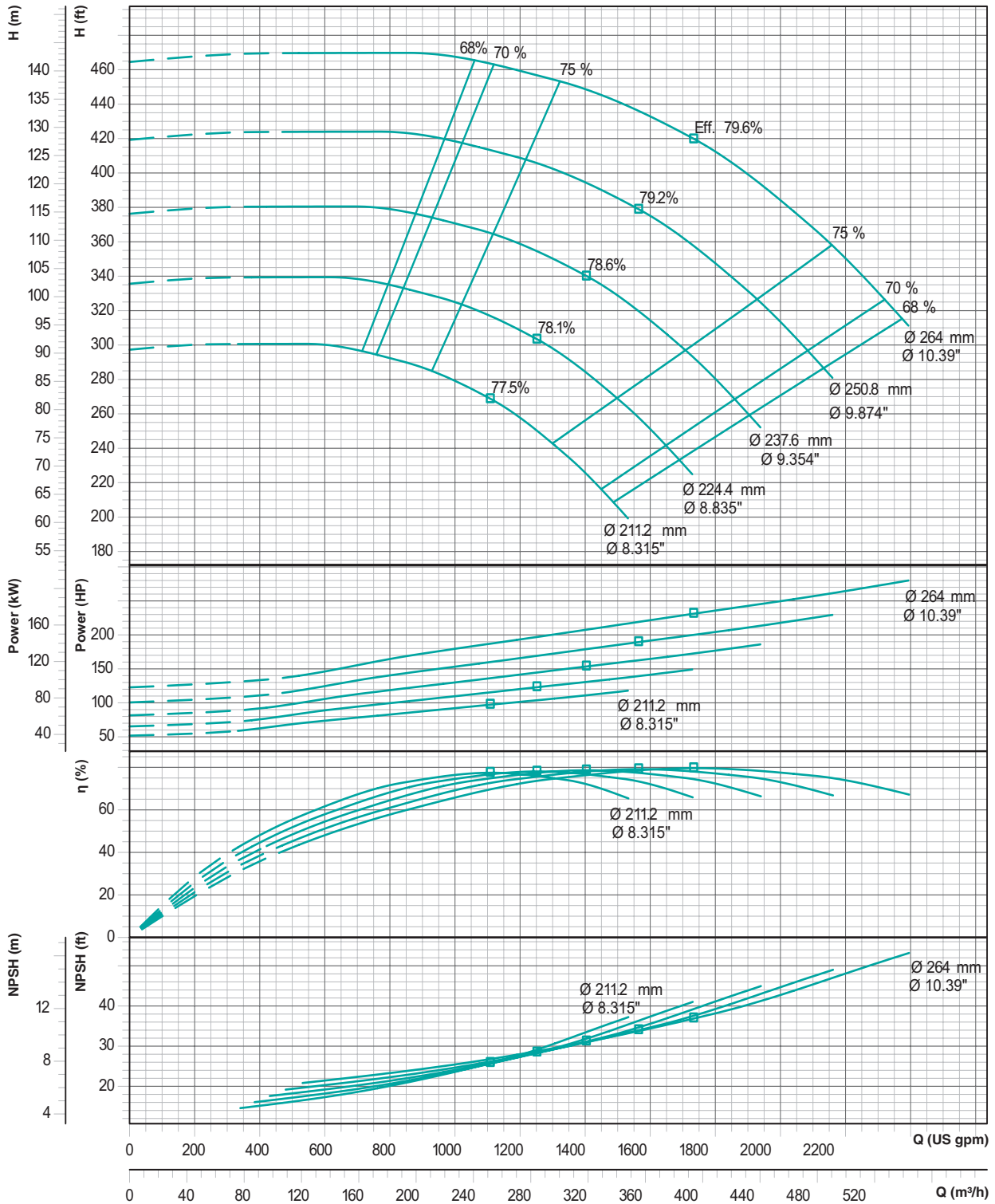

Performance curve tolerances are as per HI : 14.6 / ISO: 9906, Grade 2B

The Company reserves the right to modify the technical specifications and illustrations without prior notice.

PERFORMANCE CURVES

Model : **TEH-100-250**

Speed : **1750 rpm**

Suc x Del (in mm) : **125 x 100**

Max. Impeller Ø : **269mm**

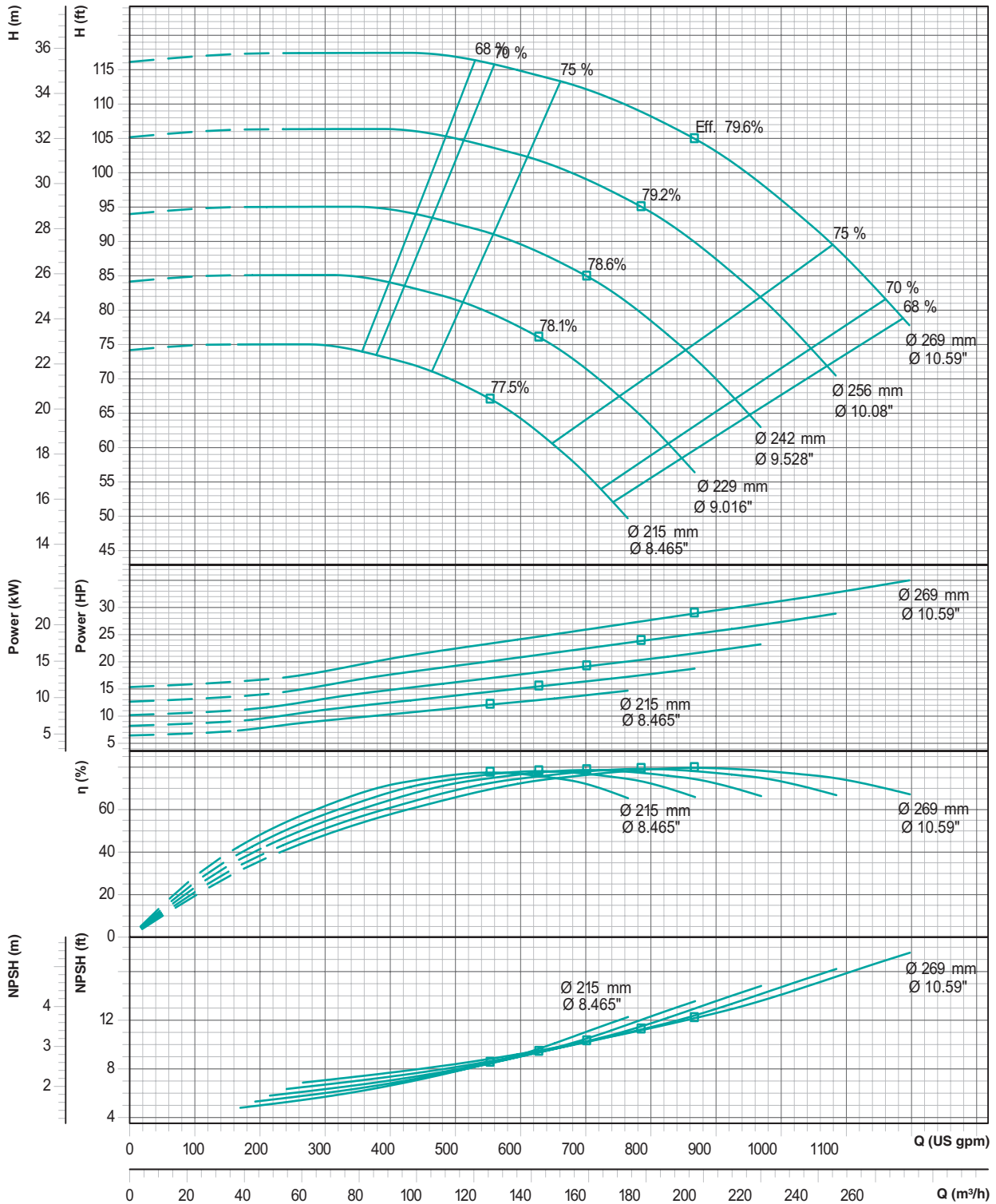

Performance curve tolerances are as per HI : 14.6 / ISO: 9906, Grade 2B

The Company reserves the right to modify the technical specifications and illustrations without prior notice.

PERFORMANCE CURVES

Model : **TEH-100-315**

Speed : **1750 rpm**

Suc x Del (in mm) : **125 x 100**

Max. Impeller Ø : **338mm**

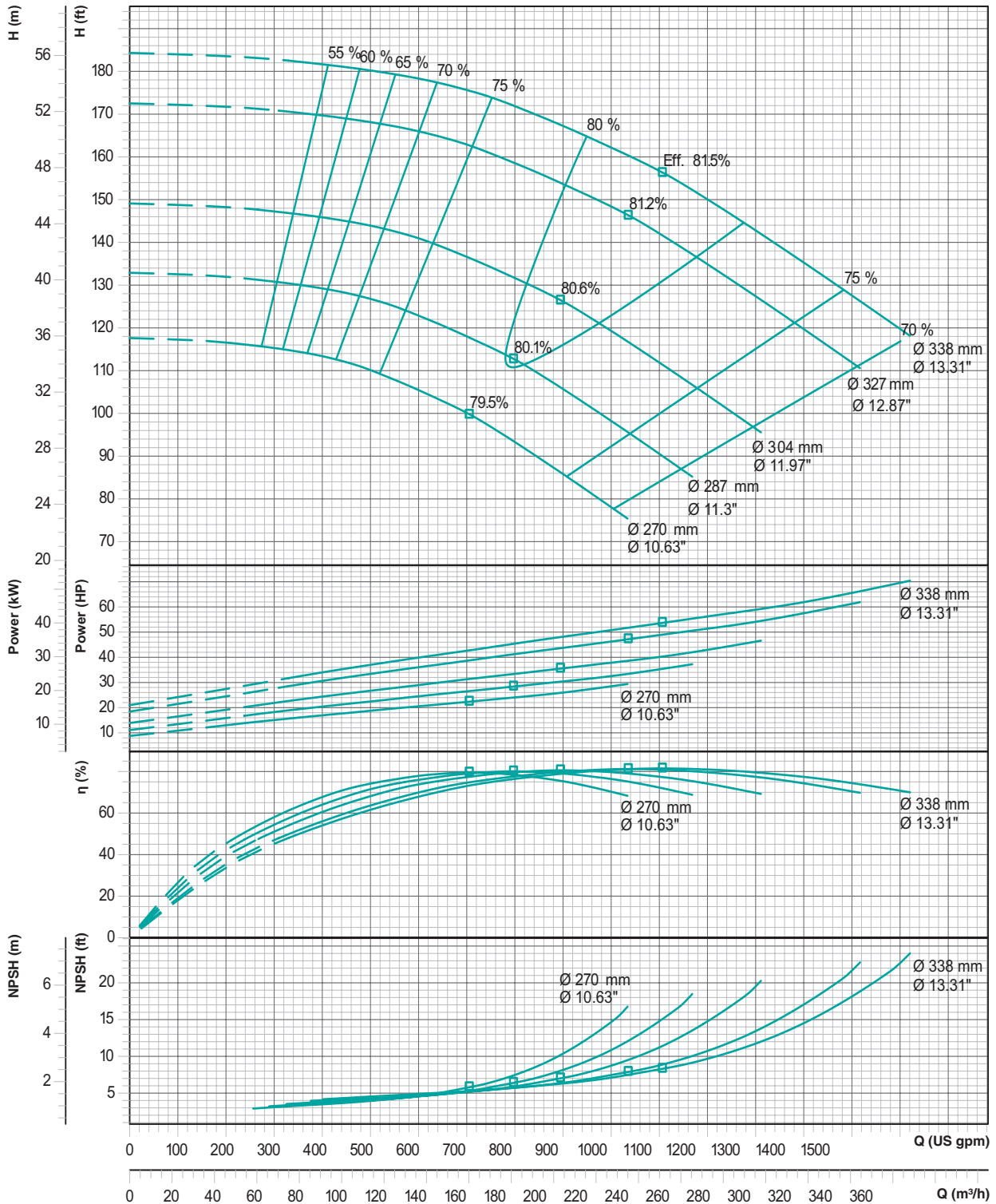

Performance curve tolerances are as per HI : 14.6 / ISO: 9906, Grade 2B

The Company reserves the right to modify the technical specifications and illustrations without prior notice.

PERFORMANCE CURVES

Model : **TEH-100-400**

Speed : **1750 rpm**

Suc x Del (in mm) : **125 x 100**

Max. Impeller Ø : **401 mm**

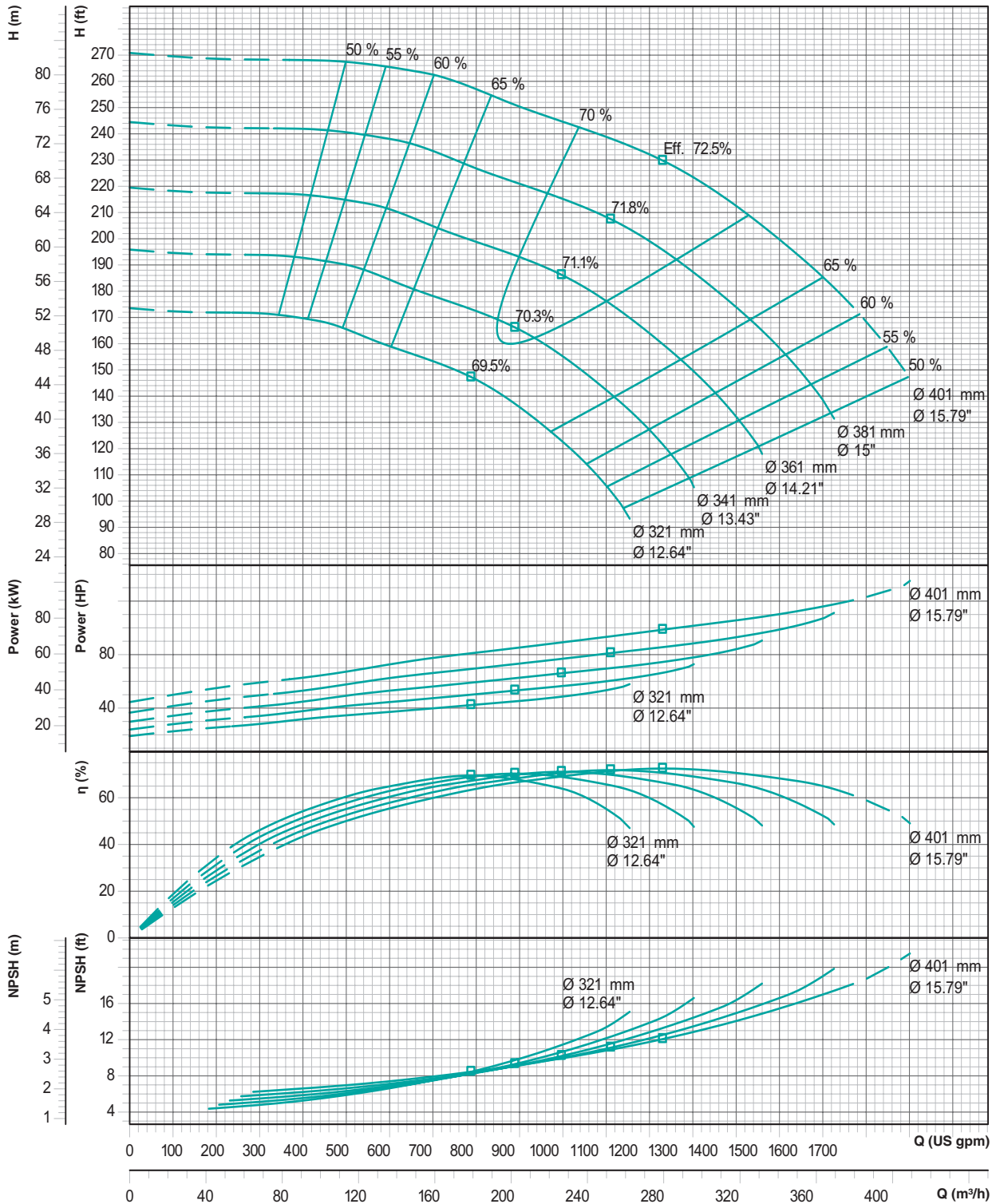

Performance curve tolerances are as per HI : 14.6 / ISO: 9906, Grade 2B

The Company reserves the right to modify the technical specifications and illustrations without prior notice.

PERFORMANCE CURVES

Model : **TEH-125-200**

Speed : **1750 rpm**

Suc x Del (in mm) : **150 x 125**

Max. Impeller Ø : **230mm**

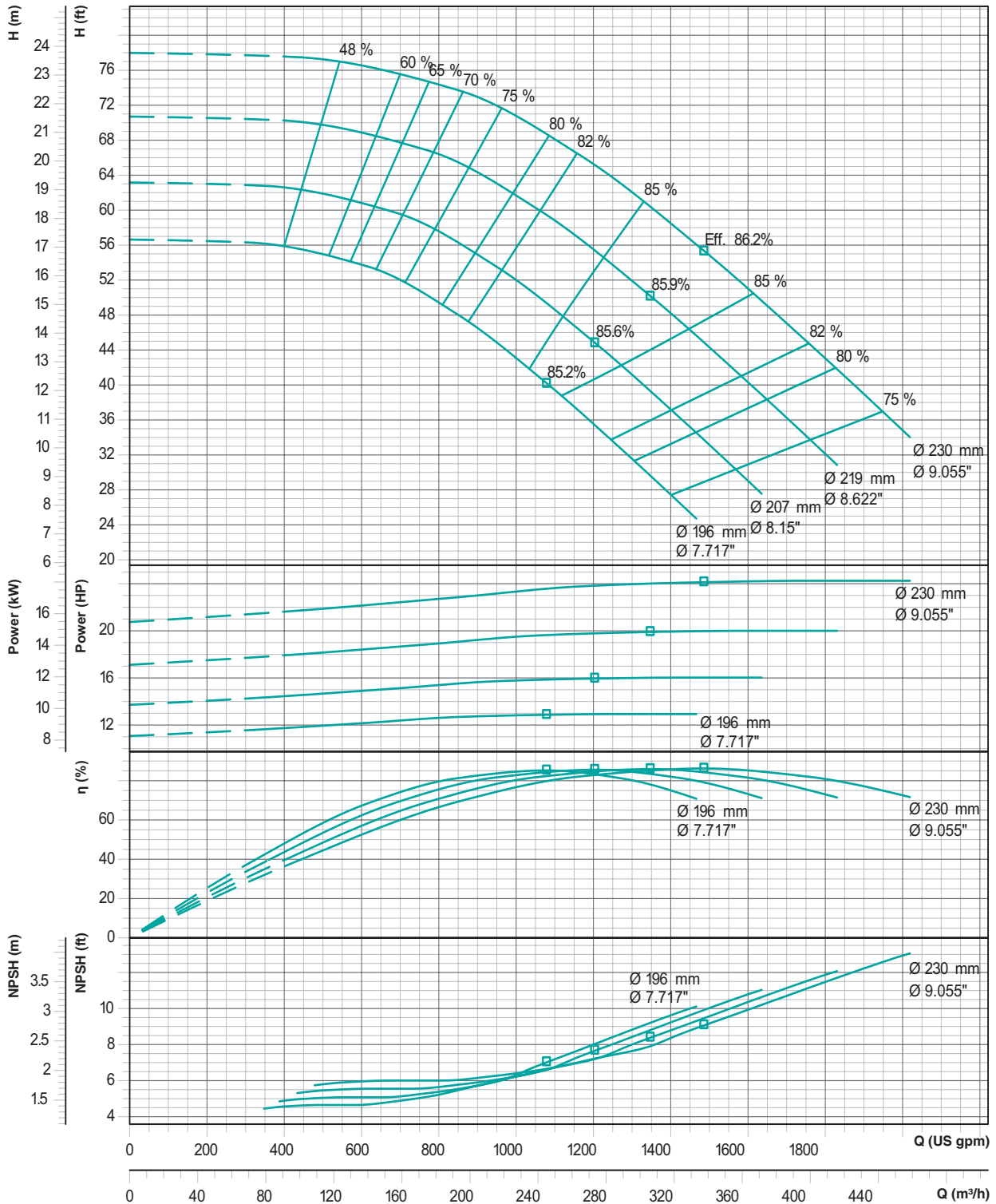

Performance curve tolerances are as per HI : 14.6 / ISO: 9906, Grade 2B

The Company reserves the right to modify the technical specifications and illustrations without prior notice.

PERFORMANCE CURVES

Model : **TEH-125-250**

Speed : **1750 rpm**

Suc x Del (in mm) : **150 x 125**

Max. Impeller Ø : **269mm**

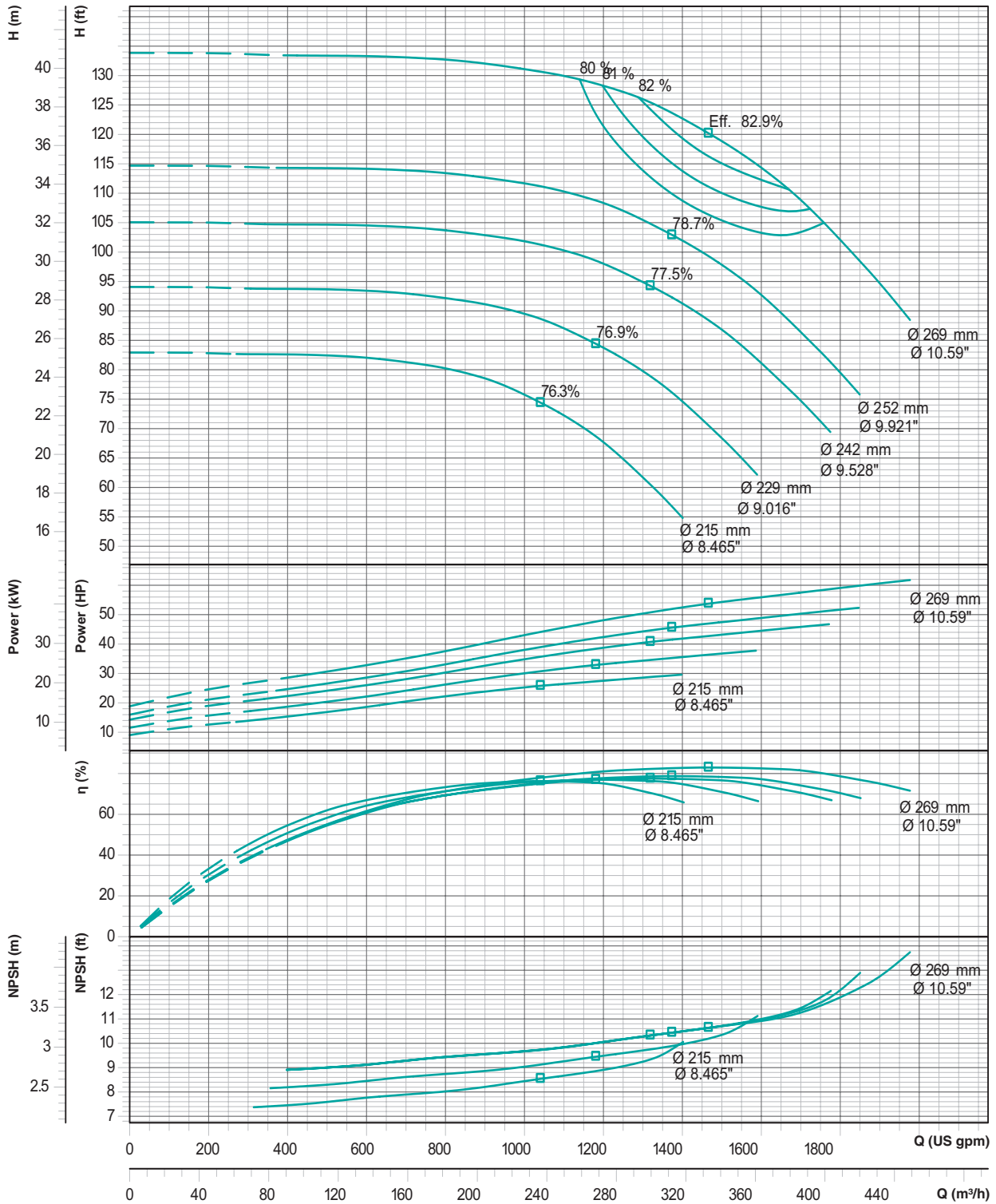

Performance curve tolerances are as per HI : 14.6 / ISO: 9906, Grade 2B

The Company reserves the right to modify the technical specifications and illustrations without prior notice.

PERFORMANCE CURVES

Model : **TEH-125-315**

Speed : **1750 rpm**

Suc x Del (in mm) : **150 x 125**

Max. Impeller Ø : **340mm**

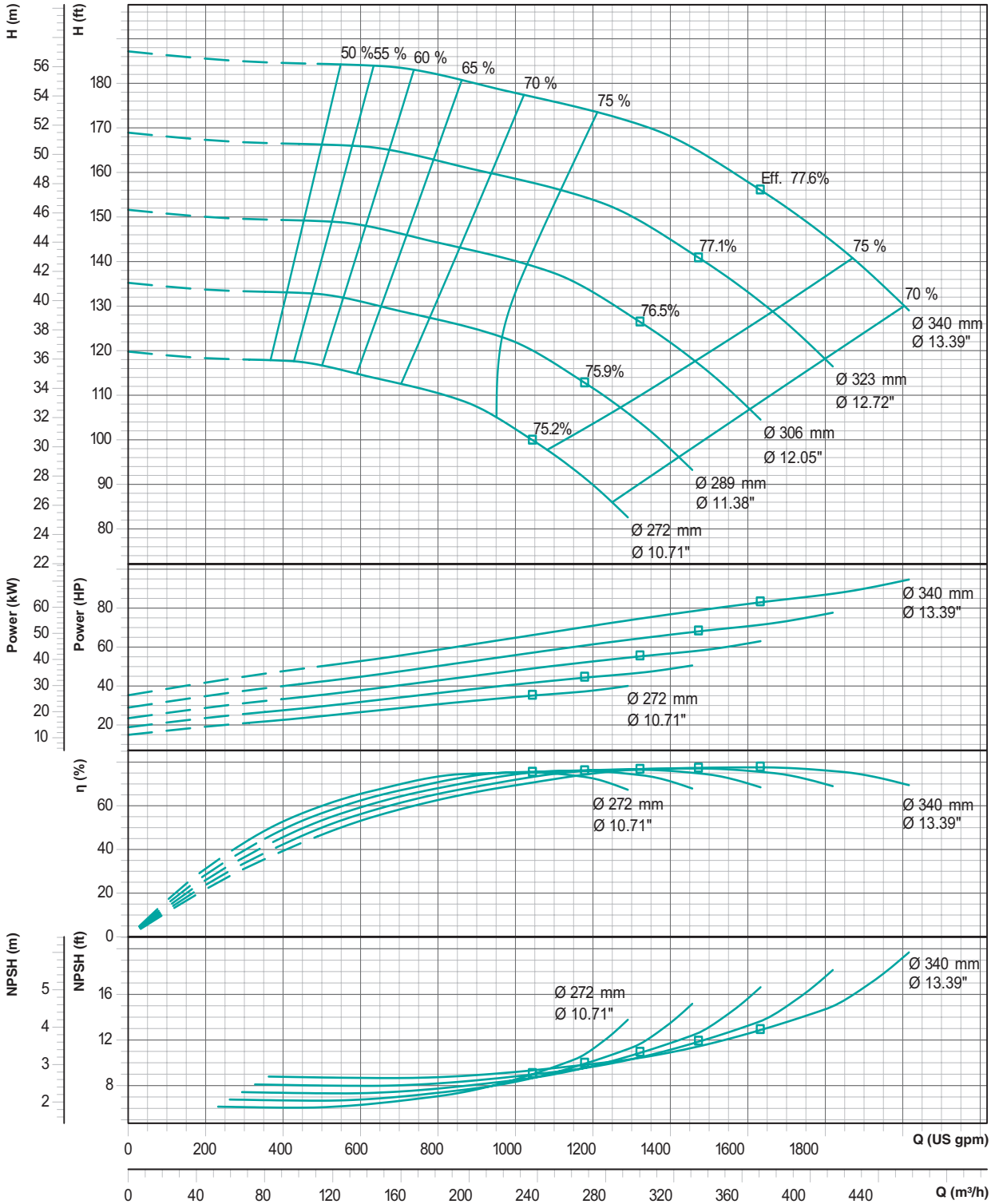

Performance curve tolerances are as per HI : 14.6 / ISO: 9906, Grade 2B

The Company reserves the right to modify the technical specifications and illustrations without prior notice.

PERFORMANCE CURVES

Model : **TEH-125-400**

Speed : **1750 rpm**

Suc x Del (in mm) : **150 x 125**

Max. Impeller Ø : **420mm**

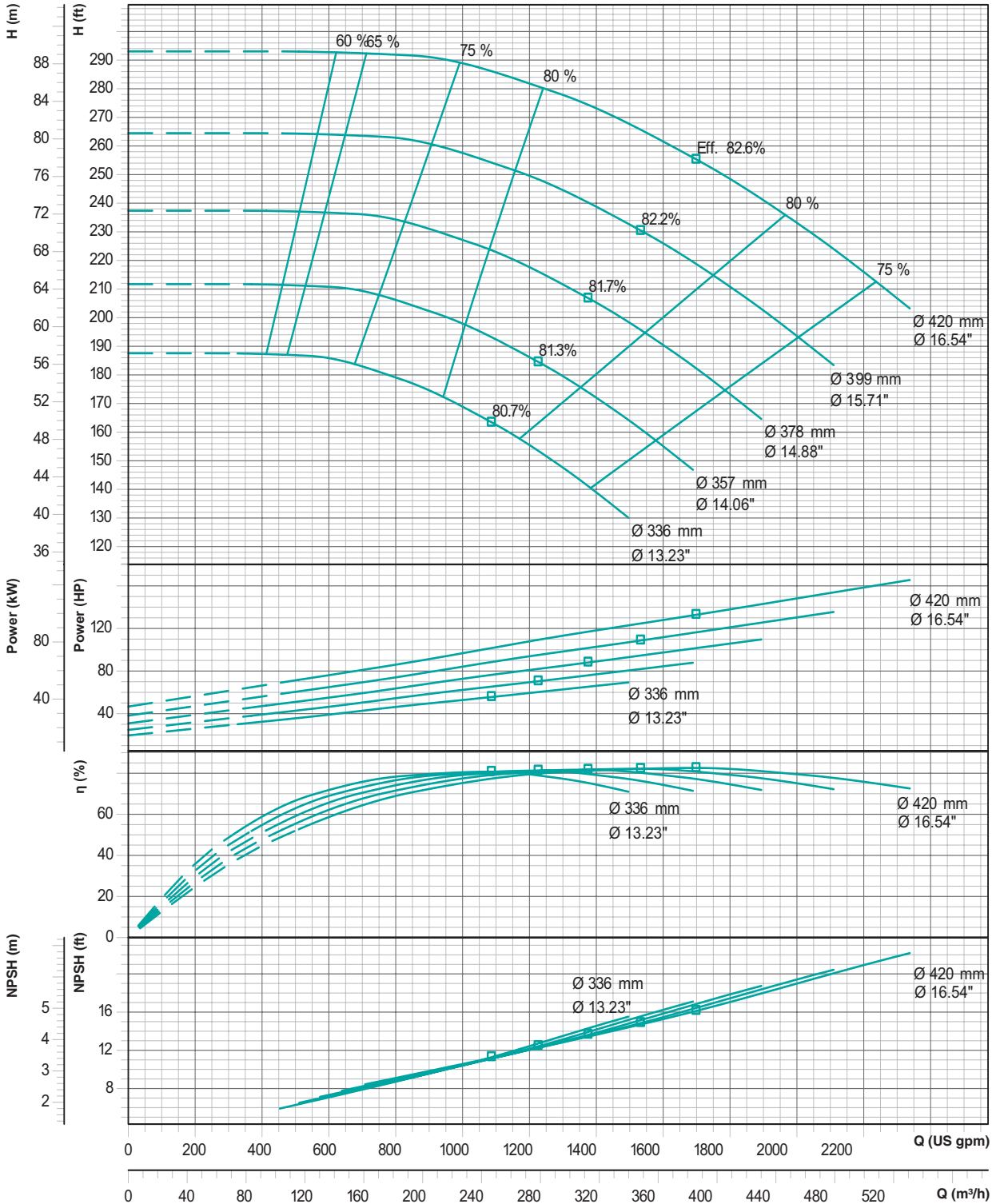

Performance curve tolerances are as per HI : 14.6 / ISO: 9906, Grade 2B

The Company reserves the right to modify the technical specifications and illustrations without prior notice.

PERFORMANCE CURVES

Model : **TEH-150-200**

Speed : **1750 rpm**

Suc x Del (in mm) : **200 x 150**

Max. Impeller Ø : **230mm**

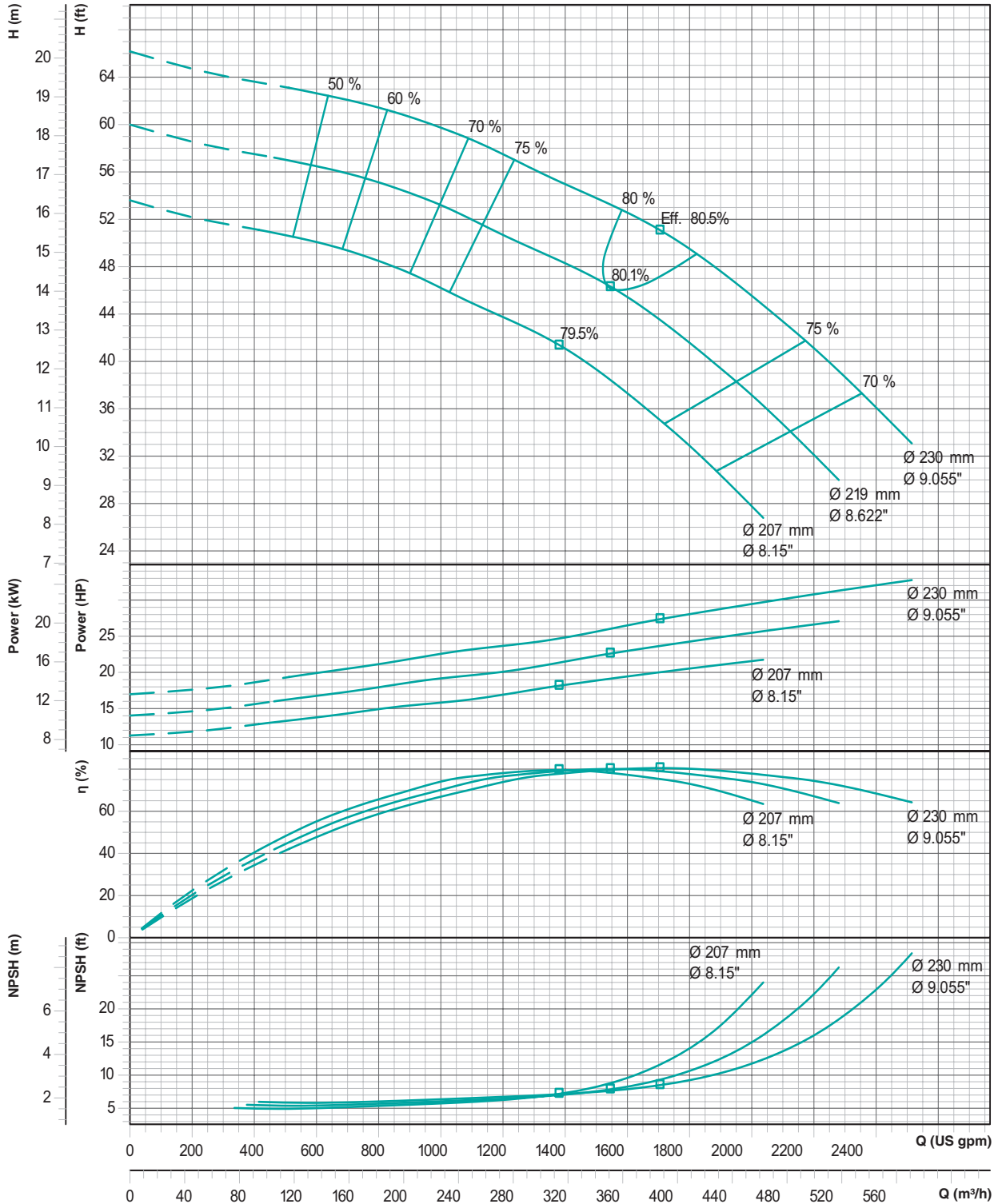

Performance curve tolerances are as per HI : 14.6 / ISO: 9906, Grade 2B

The Company reserves the right to modify the technical specifications and illustrations without prior notice.

PERFORMANCE CURVES

Model : **TEH-150-250**

Speed : **1750 rpm**

Suc x Del (in mm) : **200 x 150**

Max. Impeller Ø : **273mm**

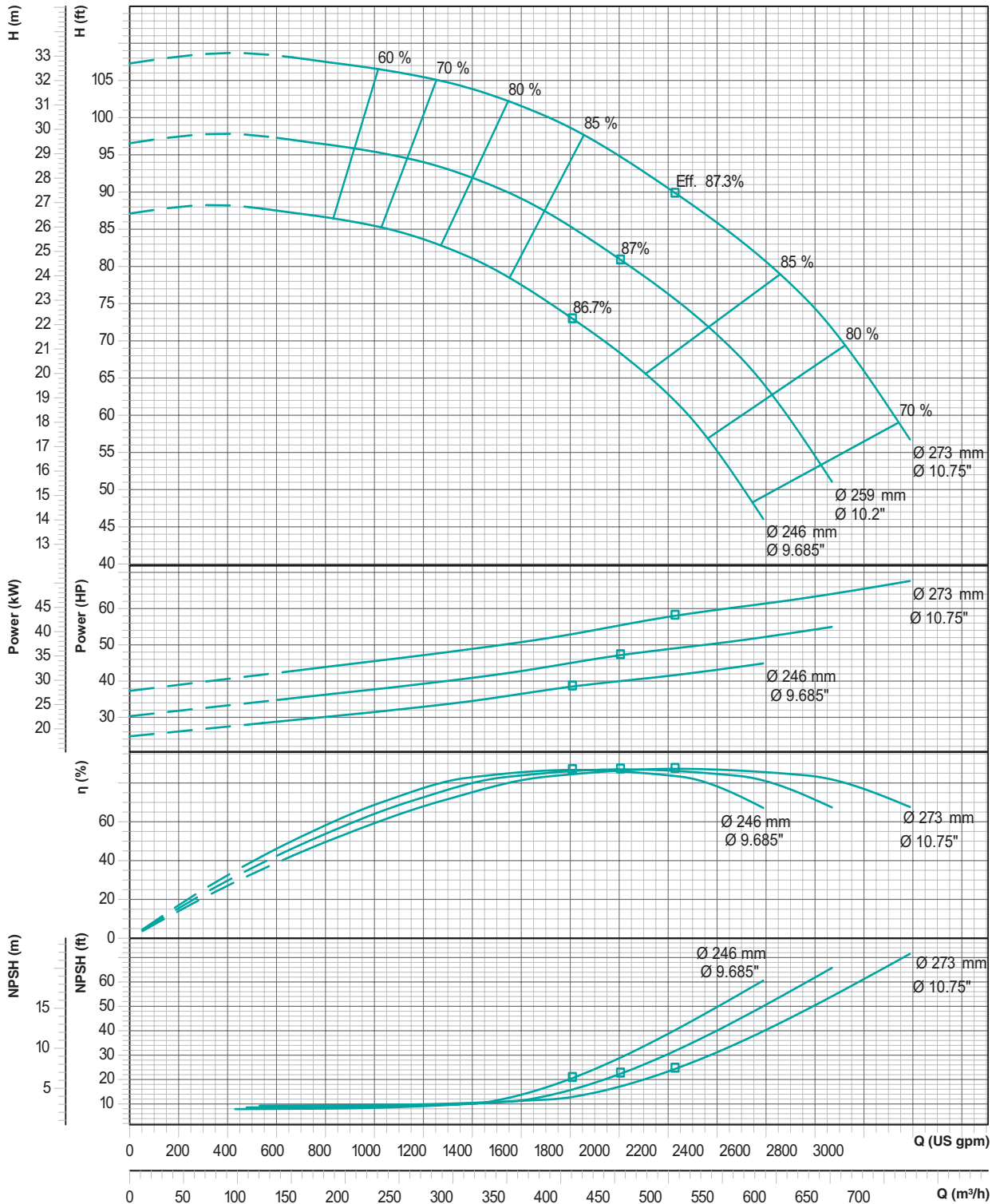

Performance curve tolerances are as per HI : 14.6 / ISO: 9906, Grade 2B

The Company reserves the right to modify the technical specifications and illustrations without prior notice.

PERFORMANCE CURVES

Model : **TEH-150-315**

Speed : **1750 rpm**

Suc x Del (in mm) : **200 x 150**

Max. Impeller Ø : **338mm**

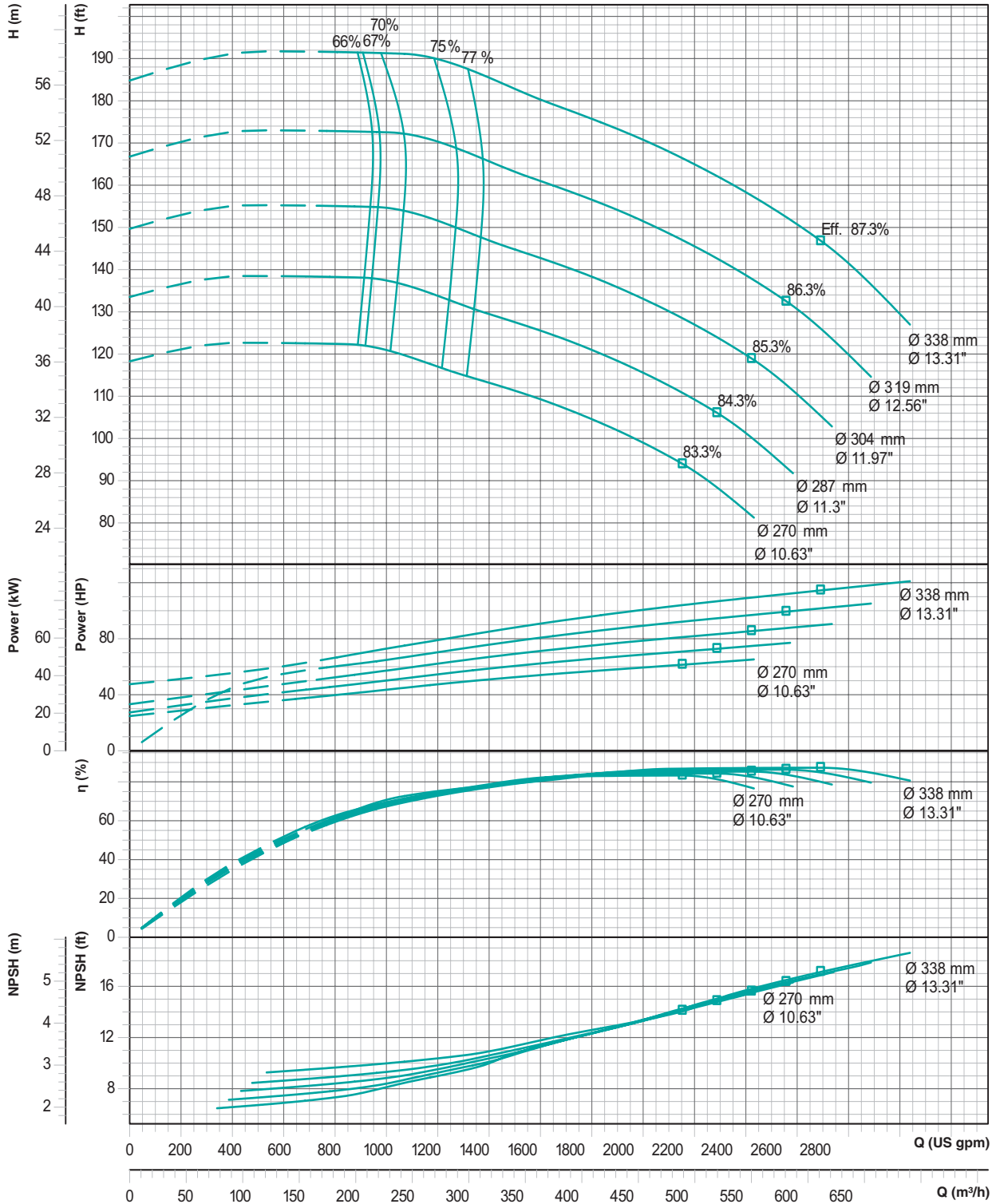

Performance curve tolerances are as per HI : 14.6 / ISO: 9906, Grade 2B

The Company reserves the right to modify the technical specifications and illustrations without prior notice.

PERFORMANCE CURVES

Model : **TEH-150-400**

Speed : **1750 rpm**

Suc x Del (in mm) : **200 x 150**

Max. Impeller Ø : **409mm**

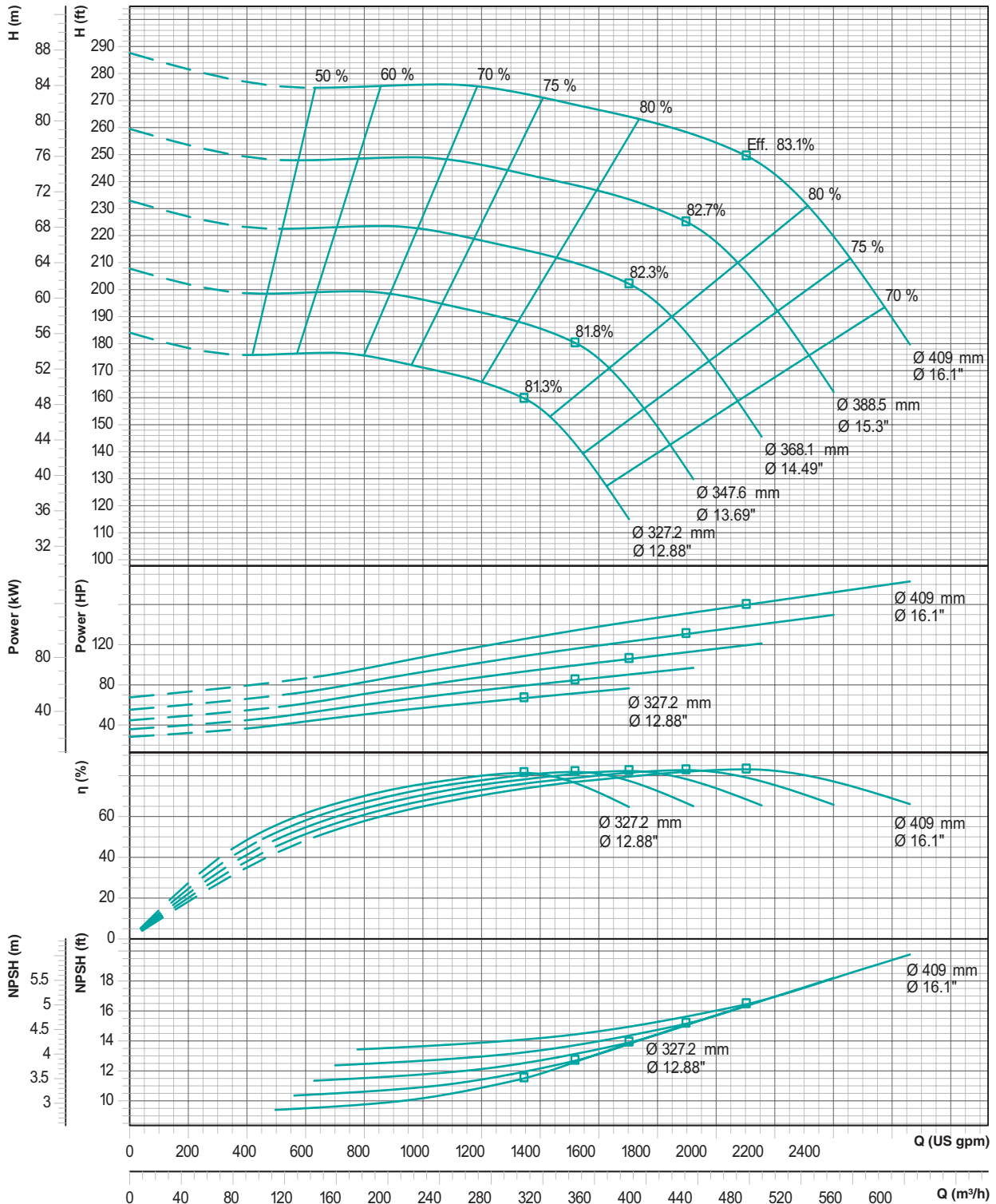

Performance curve tolerances are as per HI : 14.6 / ISO: 9906, Grade 2B

The Company reserves the right to modify the technical specifications and illustrations without prior notice.

STUFFING BOX DETAILS

Standard Mechanical Seal Housing

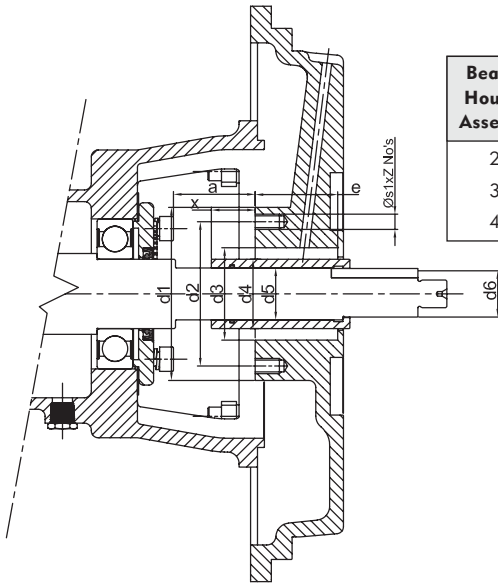

Bearing Housing Assembly	x	e	d1	d2	d3	d4	d5	Seal O.D	Gland O.D	L1	OP.Lth	L2	s1xZnos
25	18	60	84	65	51	30	25	49	80~84	3	26.5	7.5	4xM8
32	20	60	94	80	61	38	32	59	92~96	3	30	9	4xM8
42	35	71.5	150	125	80	53	45	78.5	130~135	6	33	11	4xM12

Flange Dimensions - PN 16

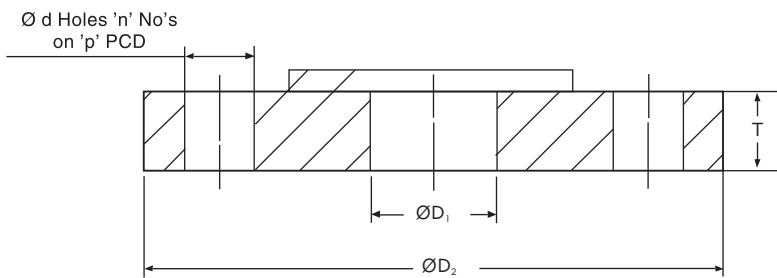

S.No	Ø D1	Ø D2	P	n	Ø d	T
1	25	115	85	4	14	16
2	32	140	100	4	18	18
3	40	150	110	4	18	19
4	50	165	125	4	18	19
5	65	185	145	4	18	20
6	80	200	160	8	18	22
7	100	220	180	8	18	24
8	125	250	210	8	18	19
9	150	285	240	8	22	26

INTERCHANGEABILITY CHART

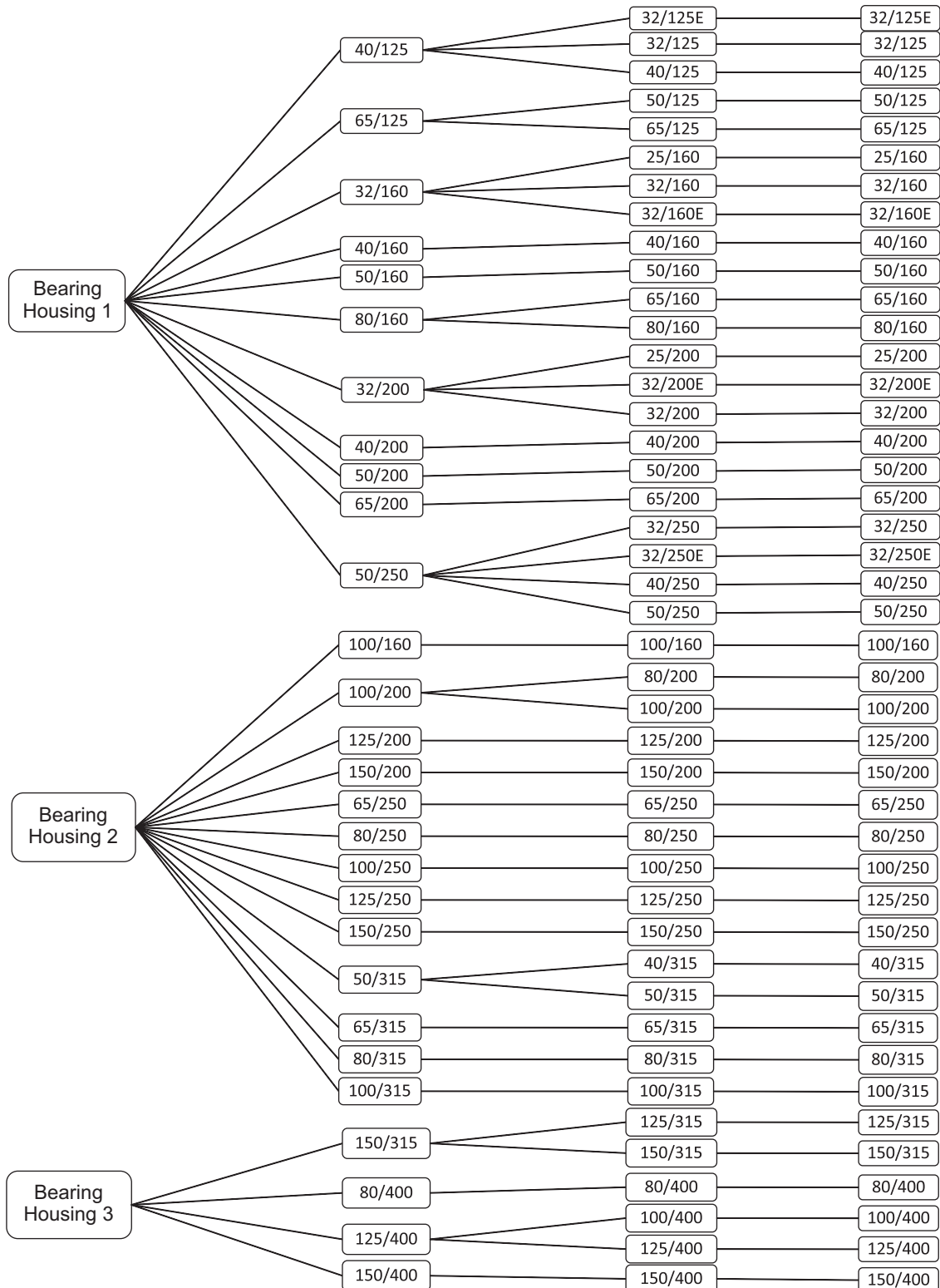
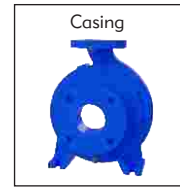

BARE SHAFT PUMP - MOUNTING DIMENSIONS (STANDARD DESIGN)

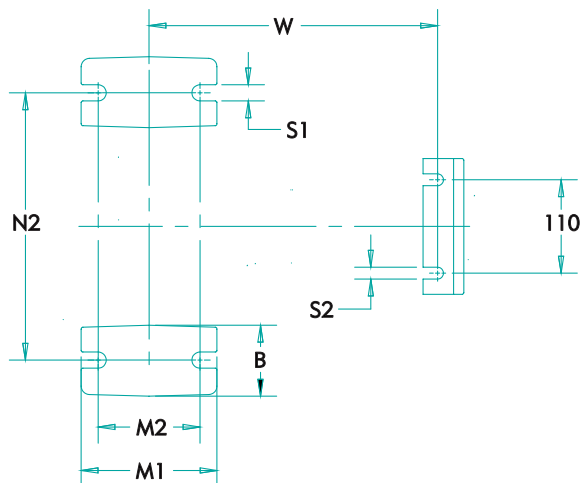
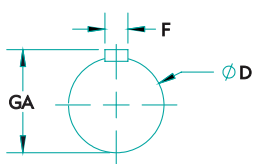
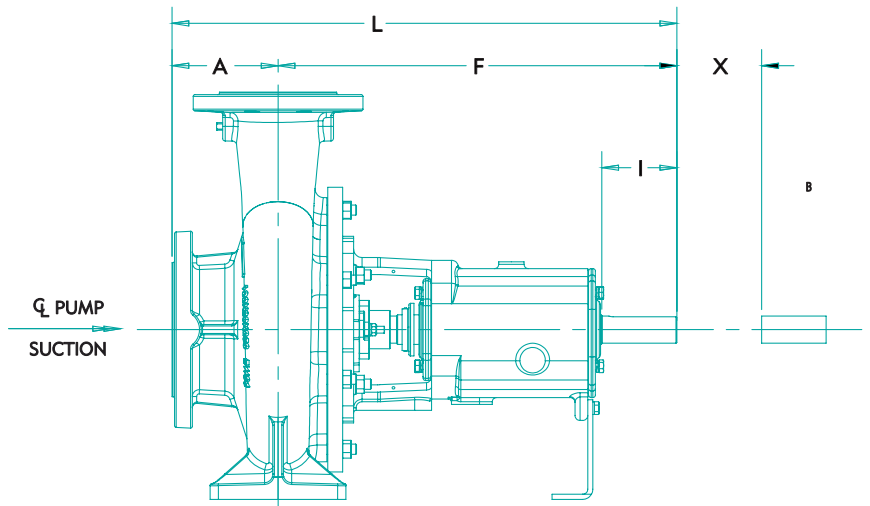
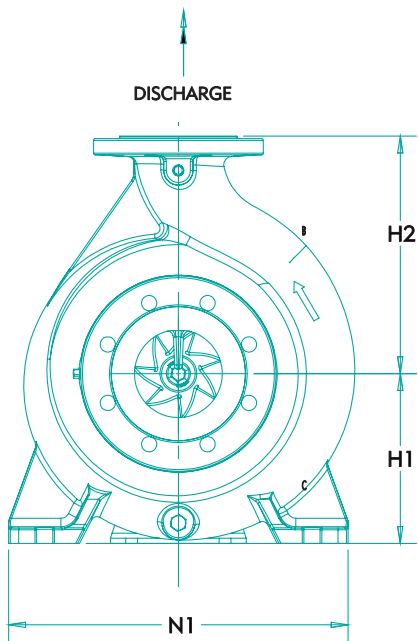

The Company reserves the right to modify the technical specifications and illustrations without prior notice.

BARE SHAFT PUMP - MOUNTING DIMENSIONS (STANDARD DESIGN)

Pump Size Del / Imp Ø (mm)	Suction size (mm)	Delivery size (mm)	SHAFT			A	F	H1	H2	B	M1	M2	N1	N2	S1	S2	W	X	Shaft Extension (l)	Total Length (L)
			ØD	GA	F															
32/125E	50	32	24	27	8	80	360	112	140	50	100	70	190	140	14	14	260	100	50	440
32/125	50	32	24	27	8	80	360	112	140	50	100	70	190	140	14	14	260	100	50	440
40/125	65	40	24	27	8	80	360	112	140	50	100	70	210	160	14	14	260	100	50	440
50/125	65	50	24	27	8	100	360	132	180	50	100	70	240	190	14	14	260	100	50	460
65/125	80	65	24	27	8	100	360	160	180	65	125	95	280	212	14	14	260	100	50	460
25/160	40	25	24	27	8	80	360	132	160	50	100	70	240	190	14	14	260	100	50	440
32/160	50	32	24	27	8	80	360	132	160	50	100	70	240	190	14	14	260	100	50	440
32/160E	50	32	24	27	8	80	360	132	160	50	100	70	240	190	14	14	260	100	50	440
40/160	65	40	24	27	8	80	360	132	160	50	100	70	240	190	14	14	260	100	50	440
50/160	65	50	24	27	8	100	360	160	180	50	100	70	265	212	14	14	260	100	50	460
65/160	80	65	24	27	8	100	360	160	200	65	125	95	280	212	14	14	260	100	50	460
80/160	100	80	24	27	8	125	360	180	225	65	125	95	320	250	14	14	260	140	50	485
25/200	40	25	24	27	8	80	360	160	180	50	100	70	240	190	14	14	260	100	50	440
32/200E	50	32	24	27	8	80	360	160	180	50	100	70	240	190	14	14	260	100	50	440
32/200	50	32	24	27	8	80	360	160	180	50	100	70	240	190	14	14	260	100	50	440
40/200	65	40	24	27	8	100	360	160	180	50	100	70	265	212	14	14	260	100	50	460
50/200	65	50	24	27	8	100	360	160	200	50	100	70	265	212	14	14	260	100	50	460
65/200	80	65	24	27	8	100	360	180	225	65	125	95	320	250	14	14	260	140	50	460
32/250	50	32	24	27	8	100	360	180	225	65	125	95	320	250	14	14	260	100	50	460
32/250E	50	32	24	27	8	100	360	180	225	65	125	95	320	250	14	14	260	100	50	460
40/250	65	40	24	27	8	100	360	180	225	65	125	95	320	250	14	14	260	100	50	460
50/250	65	50	24	27	8	100	360	180	225	65	125	95	320	250	14	14	260	100	50	460
100/160	125	100	32	35	10	125	470	200	280	80	160	120	360	280	19	14	340	140	80	595
80/200	100	80	32	35	10	125	470	180	250	65	125	95	345	280	14	14	340	140	80	485
100/200	125	100	32	35	10	125	470	200	280	80	160	120	360	280	19	14	340	140	80	595
125/200	150	125	32	35	10	140	470	250	315	80	160	120	400	315	19	14	340	140	80	610
150/200	200	150	32	35	10	160	470	280	400	100	200	150	550	450	24	14	340	140	80	630
65/250	80	65	32	35	10	100	470	200	250	80	160	120	360	280	19	14	340	140	80	570
80/250	100	80	32	35	10	125	470	200	280	80	160	120	400	315	19	14	340	140	80	595
100/250	125	100	32	35	10	140	470	225	280	80	160	120	400	315	19	14	340	140	80	610
125/250	150	125	32	35	10	140	470	250	355	80	160	120	400	315	19	14	340	140	80	610
150/250	200	150	32	35	10	160	470	280	400	100	200	250	500	400	24	14	340	140	80	630
40/315	65	40	32	35	10	125	470	250	250	65	125	95	345	280	14	14	340	140	80	595
50/315	65	50	32	35	10	125	470	225	280	65	125	95	345	280	14	14	340	140	80	595
65/315	80	65	32	35	10	125	470	225	280	80	160	120	400	315	19	14	340	140	80	595
80/315	100	80	32	35	10	125	470	250	315	80	160	120	400	315	19	14	340	140	80	595
100/315	125	100	32	35	10	140	470	250	315	80	160	120	400	315	18	14	340	140	80	610
125/315	150	125	42	45	12	140	530	280	355	100	200	150	500	400	24	14	370	140	110	670
150/315	200	150	42	45	12	160	530	280	400	100	200	150	550	450	24	14	370	140	110	690
80/400	100	80	42	45	12	125	530	280	355	80	160	120	435	355	19	14	370	140	110	655
100/400	125	100	42	45	12	140	530	280	355	100	200	150	500	400	22	14	370	140	110	670
125/400	150	125	42	45	12	140	530	315	400	100	200	150	500	400	22	14	370	140	110	670
150/400	200	150	42	45	12	160	530	315	450	100	200	150	550	450	22	14	370	140	110	690

Note : All Dimensions are in mm, Unless Otherwise Specified

BARE SHAFT PUMP - MOUNTING DIMENSIONS (PEDESTAL DESIGN)

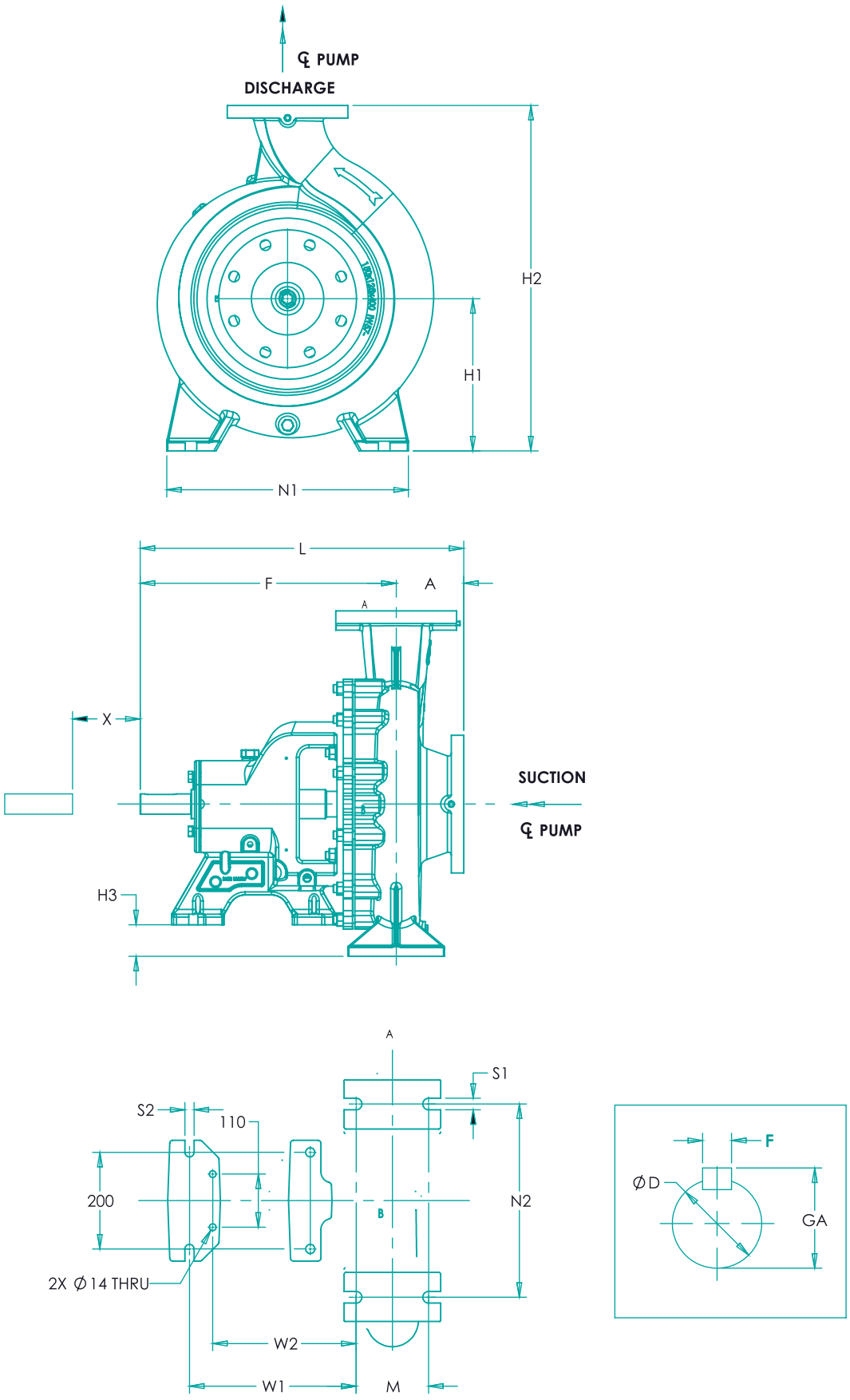

The Company reserves the right to modify the technical specifications and illustrations without prior notice.

BARE SHAFT PUMP - MOUNTING DIMENSIONS (PEDESTAL DESIGN)

PUMP SIZE Del / Imp Ø (mm)	SPEED (rpm)	SUCTION FLANGE DIMENSIONS (DIN PN16)					DISCHARGE FLANGE DIMENSIONS (DIN PN16)				
		O/D DIA	I/D DIA	NO. OF HOLES	DIA OF HOLES	P.C.D	O/D DIA	I/D DIA	NO. OF HOLES	DIA OF HOLES	P.C.D
TEH 80/400	1450	230	100	8	18	180	200	80	8	18	160
TEH 80/415	1450	230	100	8	18	180	200	80	8	18	160
TEH 100/400	1450	250	125	8	18	210	220	100	8	18	180
TEH 100/415	1450	250	125	8	18	210	220	100	8	18	180
TEH 125/315	1450	285	150	8	22	240	250	125	8	18	210
TEH 125/400	1450	285	150	8	22	240	250	125	8	18	210
TEH 150/315	1450	340	200	12	22	295	285	150	8	22	240
TEH 150/400	1450	345	200	12	22	295	285	150	8	22	240

SHAFT			L	A	F	H1	H2	H3	N1	N2	M	W1	W2	S1	S2	X
ØD	GA	F														
42	45	12	655	125	530	280	635	30	435	355	120	360	312	19	19	140
42	45	12	655	125	530	280	630	30	435	355	120	360	312	19	19	140
42	45	12	670	140	530	280	635	30	500	400	150	345	297	24	19	140
42	45	12	670	140	530	280	680	30	500	400	150	345	297	24	19	140
42	45	12	670	140	530	280	635	30	500	400	150	345	297	24	19	140
42	45	12	670	140	530	315	715	65	500	400	150	345	297	24	19	140
42	45	12	690	160	530	280	680	30	550	450	150	345	297	24	19	140
42	45	12	690	160	530	315	765	65	550	450	150	345	297	24	19	140

Note : All Dimensions are in mm, Unless Otherwise Specified



T H E P O W E R B E H I N D T H E F O R C E

Naargo Industries Private Limited, one of the leading manufacturers of latest state of art, large range of pumps and motors, is managed by veterans who are in the pump industry for almost half a century. The products are employed in various applications like irrigation, domestic, civil construction, de-watering etc; The Company has a strong distribution network in India for sales & service and a strong global presence.

Quality is the key factor in Naargo's products. The expansive infrastructure and environment accredited with ISO 9001 quality certification, latest engineering softwares, high-tech machinery, futuristic pumping technology and high caliber workforce facilitate the production of flawless and efficient products on par with international standards under the brand name of "Tormac". The well equipped R & D wing stays alive to the changing global trends and comes out with viable solutions for innovative product development and upgradation.

The Products currently available include Stainless Steel Submersible Pumps (SS 304, SS 316 & SS 904L), Submersible Motors (CI, SS 304, SS 316 & SS 904L - HT on optional), Starters & Control Panels, Centrifugal Monoblock Pumps, End Suction Pumps, Close Coupled Pumps, Horizontal Split Case Pumps, Horizontal & Vertical Multistage Pumps, Inline Booster Systems, Sewage, Drainage & Dewatering Pumps, Induction Motors, Submersible Cables, Riser Pipes and Column Pipes.

The power, performance and endurance of the products backed by the uncompromising teamwork and value systems will certainly propel the company's growth towards new horizons in the pump industry.

Naargo Industries Private Limited,

REG. OFFICE : No. 8/116, Ground Floor, Athipalayam Road, Chinnavedampatti,
Coimbatore North - 641049, Tamil Nadu, India. Tel : +91 978 6522622,
E-mail : tormac@tormacpumps.com, Web : www.tormacpumps.com