

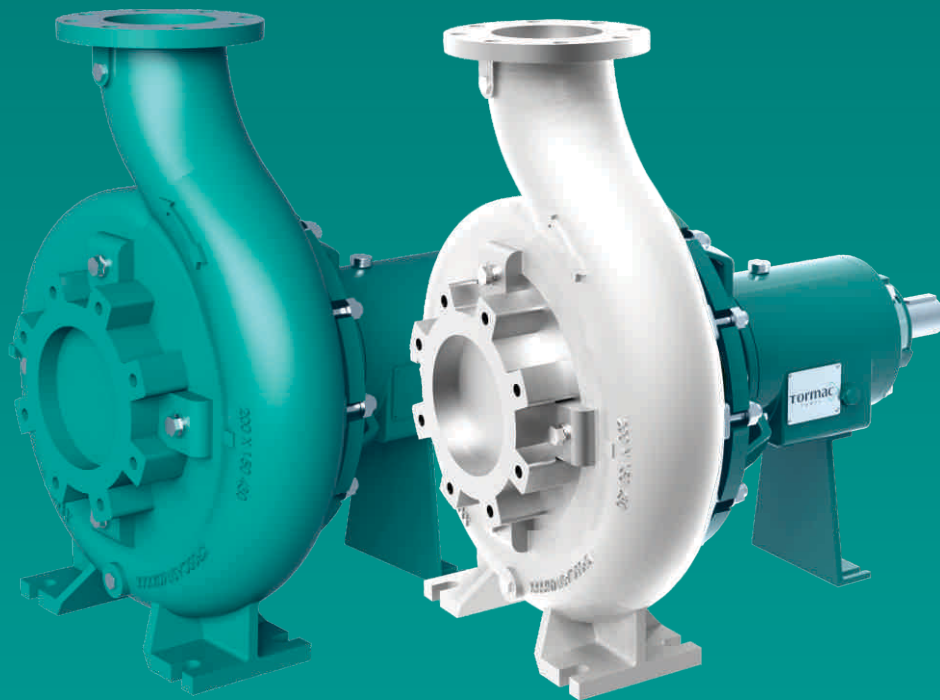

THE HARD WORKING PUMP

The result of superior technology and expertise that has stood the test of time.



END SUCTION PULP, PAPER & PROCESS PUMPS **TEP - SERIES** **50 Hz**

C O N T E N T S

END SUCTION PULP, PAPER & PROCESS PUMPS ECP SERIES (50Hz)

	Page No .
Model Identification Code & Materials of Construction	4
Description, Key Features & Applications	5
General Pump Selection, Operation Instructions & Technical Specifications	6
Exploded View	7
Cross Sectional Drawing	8
Performance Curves	9 - 41
Interchangeability Chart	42
Bare Shaft Pump - Mounting Dimensions	43
Overall Range and performance Details	44 - 46

GENERAL DATA

Model Identification Code

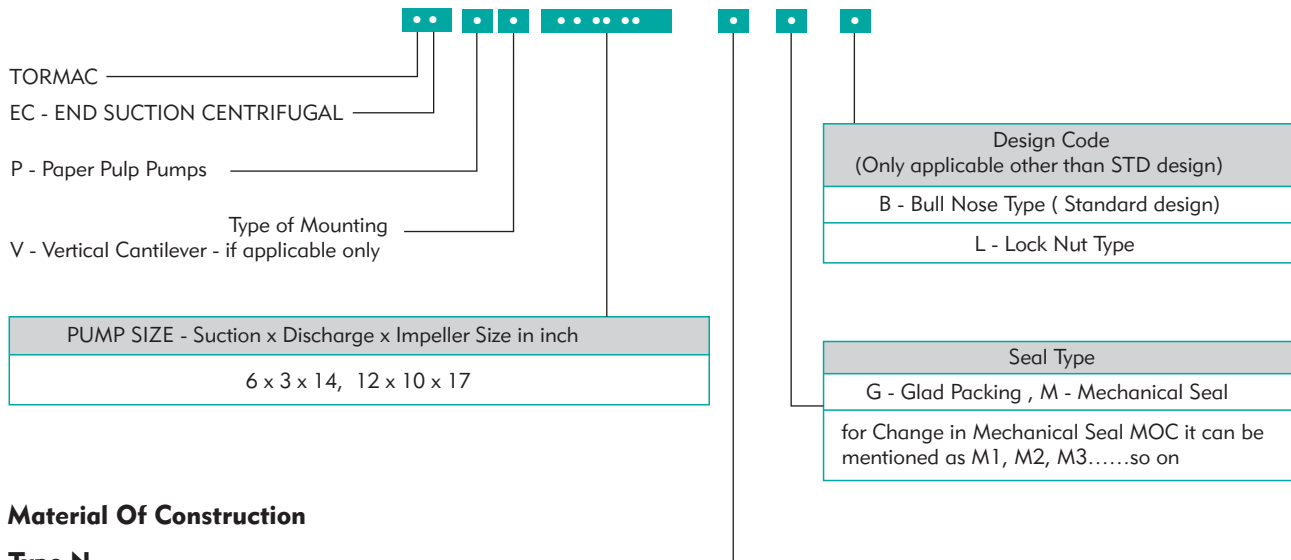

Material Of Construction

Type N

Parts Name	Material	EUROPEAN	DIN	SAE/AISI
Pump Casing	CF8M	X6CrNiMo 18 10	1.4408	ASTM A743 / A351 CF8M
Impeller	CF8M	X6CrNiMo 18 10	1.4408	ASTM A743 / A351 CF8M
Shaft	CF8M	X5CrNiMo 18 10	1.4401	ASTM A276 AISI 316
Shaft Sleeve	CF8M	X5CrNiMo 18 10	1.4401	ASTM A276 AISI 316
Side Plate	CF8M	X6CrNiMo 18 10	1.4408	ASTM A743 / A351 CF8M
Stuffing Box & Gland	CF8M	X6CrNiMo 18 10	1.4408	ASTM A743 / A351 CF8M
Bearing Housing & Connecting Frame	Cast Iron	EN-GJL-220	(0.6020) GG20	ASTM A48 class 30B

Type S

Parts Name	Material	EUROPEAN	DIN	SAE/AISI
Pump Casing	CF8	X5CrNi18-9	1.4308	ASTM A743 / A351 CF8
Impeller	CF8	X5CrNi18-9	1.4308	ASTM A743 / A351 CF8
Shaft	CF8	X5CrNi18-10	1.4301	ASTM A276 AISI 304
Shaft Sleeve	CF8	X5Cr18-10	1.4308	ASTM A276 AISI 304
Side Plate	CF8	X5CrNi18-9	1.4308	ASTM A743 / A351 CF8
Stuffing Box & Gland	CF8	X5CrNi18-9	1.4308	ASTM A743 / A351 CF8
Bearing Housing & Connecting Frame	Cast Iron	EN-GJL-220	(0.6020) GG20	ASTM A48 class 30B

General Instructions

- Performance curves are as per specific gravity and viscosity of water.
- Performance curve tolerances are as per HI : 14.6 / ISO: 9906, Grade 2B
- For Safety consider a margin of 0.5m higher of NPSH.
- All dimensions are in mm

END SUCTION PULP, PAPER & PROCESS PUMPS > TEP - SERIES

The TEP Series End Suction Pumps are robustly engineered to deliver high-efficiency, dependable performance in the most demanding industrial environments. Specifically designed for processing challenging fluids such as paper stock, pulp, and fibrous slurries, the TEP Series is an ideal solution for applications in the pulp & paper, sugar, food, and dairy industries.

Capable of handling slurries with consistencies up to 8%, these pumps excel in transferring thick, viscous, and solids-laden media. A key feature of the TEP Series is its adjustable impeller-to-wear plate clearance, which allows for precise performance tuning and significantly extends the service life of internal components. This adjustability is achieved through a simple shim system, enabling easy and accurate maintenance.

The pumps boast a modular design with interchangeable spare parts, simplifying servicing and minimizing downtime. This modularity contributes to reduced inventory costs and increased uptime for critical processes.

Offered in a variety of materials, and with gland packing and mechanical seal configurations, the TEP Series can be tailored to meet the specific operational requirements of a wide range of industries.

Key Features

Back Pull-out Design

High Efficiency

Non-Clog Semi open impeller with bull nose ensures that smooth entry of liquid with fibrous Solids.

Handle consistencies upto 8%

External Impeller adjustments to maintain optimum hydraulic performance



Applications

Paper Industry : Pulp, Paper and stock, de-inking process, bleaching, contaminated process liquids, pulp slurry, waste liquids, white water circulation, cooling water circulation, condensate pumping, chemical injection

Sugar Industry : Strained and unstrained juice transfer, bagasse and molasses transfer, contaminated process liquids, waste liquids, wastewater and sludge transfer, water circulation, process water, evaporation process.

Food Industry : Food Pulp, Sauces, juice and beverage transfer, sugar syrup, glucose and other sweetener liquid transfer, canning and bottling process, cooling water circulation

Brewery and Distillery Industry : Fermented liquid transfer, Alcohol and Distilled liquid transfer, waste liquid transfer, water circulation, canning and bottling process, cooling water circulation

Dairy Industry : milk and cream transfer, additive transfer, whey transfer, cooling water circulation.

Edible oil Industry : Solvent and oil transfer, acid and additive transfer, loading and unloading of oils, Canning and bottling process, cooling water circulation, hot liquid transfer, waste oil transfer

Technical data

Head Range	10 - 102m
Flow Range	20 - 3100m ³ /h
Speed	720 / 960 / 1450 rpm
Impeller Type	Semi Open Impeller
Outlet Size	2½"- 14"
Power Range	2 - 298 kW
Maximum Liquid Temperature	-10°C to 90°C
Shaft Seal	Standard : Gland Packing
	Optional : Mechanical Seal
Bearing Lubrication	Oil
Flange Standard	ASME 16.5 Class 150
Maximum working Pressure	12 - 16 bar

General Pump Selection & Operation Instructions

1. All performance curves are based on water (specific gravity = 1.0; low viscosity). Corrections must be applied for fluids with different properties.
2. Select a motor or engine with sufficient power margin above the pump duty point. This prevents overloading under normal and transient operating conditions.
3. Always calculate NPSHA (Net Positive Suction Head Available) carefully, especially when pumping hot or cold liquids with negative or positive suction. Account for vapor pressure effects.
4. Ensure $NPSHA \geq NPSHR + 0.5m$ to avoid cavitation during both negative and positive suction conditions.
5. For high-viscosity fluids, apply viscosity correction factors to head, flow and efficiency.
6. Choose pumps to operate within 70% to 120% of the Best Efficiency Point (BEP) against flow. Operating within this range ensures better efficiency, reliability, and reduced wear.
7. Select pump materials based on fluid properties:
 - i. Chemical compatibility
 - ii. Operating temperature
 - iii. Abrasiveness or corrosiveness
8. Use suction and discharge piping at least one nominal size larger than the pump nozzle to reduce friction losses and turbulence.
9. Delivery Side:
 - i. Install a Non-Return Valve (NRV) to prevent backflow.
 - ii. Install a gate or globe valve to control flow during start-up/shutdown.
10. Start-Up and Shut-Down Procedure:
 - i. Keep the delivery valve closed when starting or stopping the pump.
 - ii. For mixed flow pumps and pumps with a rising power curve toward shut-off, the pump must be started and stopped with the delivery valve in the open position, or as per the manufacturer's specific recommendations.
11. All pump performance curve tolerances conform to HI : 14.6 / ISO : 9906 Grade 2B standards.

EXPLODED VIEW

Gland Packing Construction

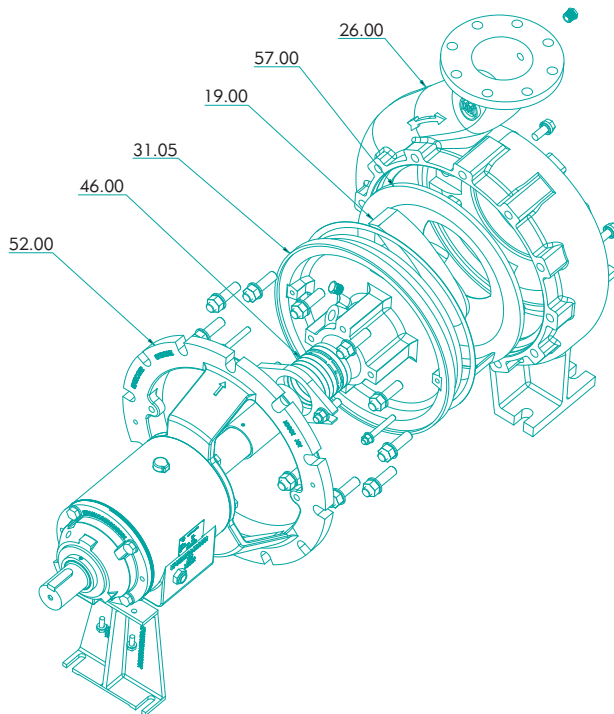

Mechanical Seal Construction

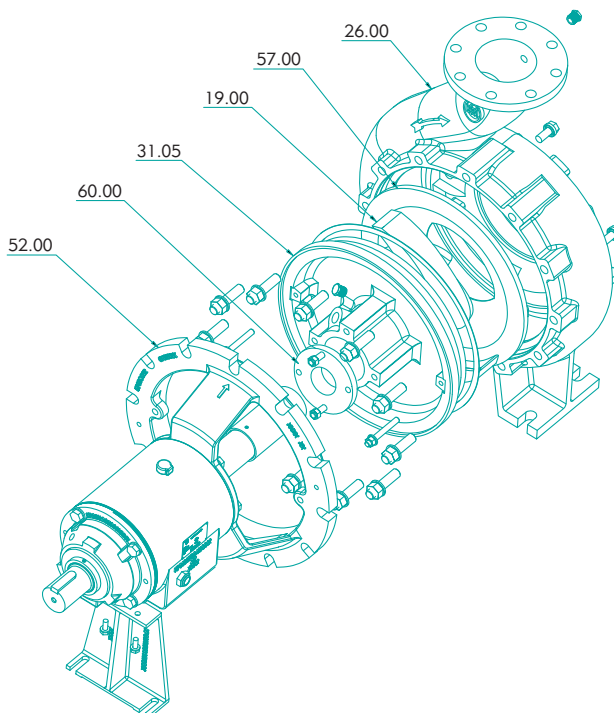

P. No.	Part Name
52.00	Connecting Frame
60.00	Mechanical Seal
31.05	Stuffing Box
19.00	Impeller
57.00	Side Plate
26.00	Casing
46.00	Gland Packing

CROSS SECTIONAL DRAWING

Gland Packing Construction

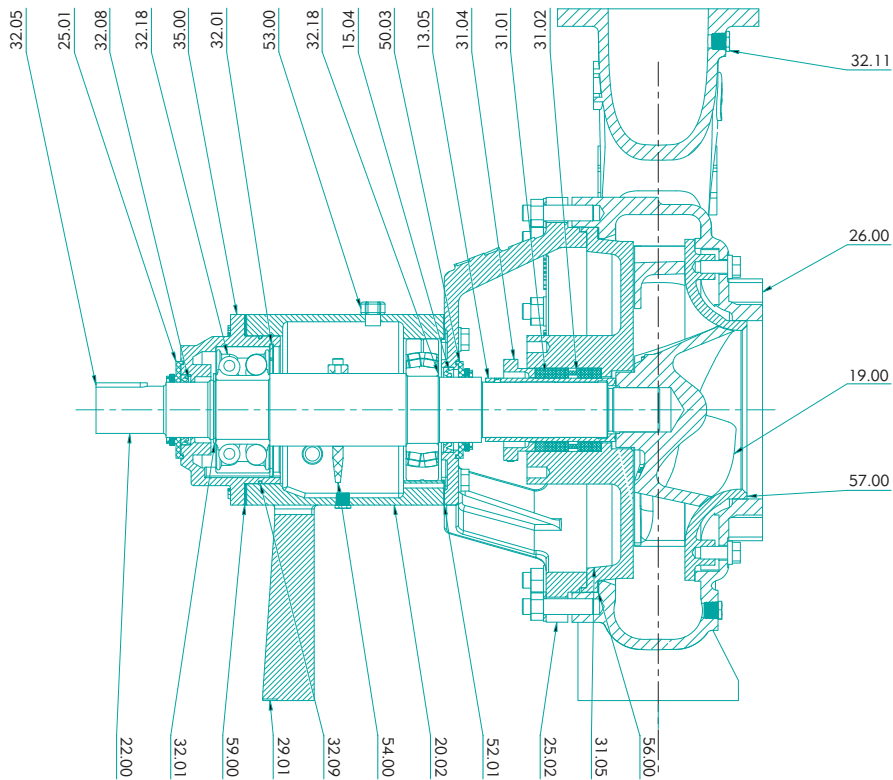

Mechanical Seal Construction

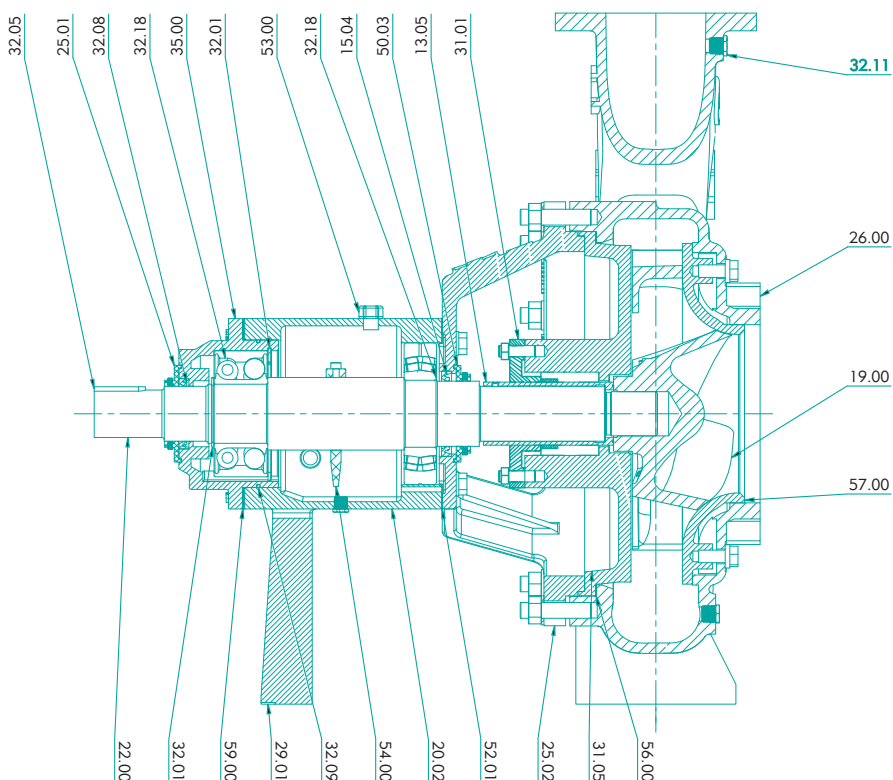

P. No.	Part Name
26.00	Casing
22.00	Shaft
19.00	Impeller
13.05	Sleeve Shaft
31.05	Stuffing Box
32.05	Parallel Key
32.18	Double Row Angular Contact Ball Bearing
32.01	Circlip External
35.00	Housing Bearing
32.01	Circlip Internal
32.09	'O' Ring
20.02	Bearing Frame
32.18	Spherical Roller Bearing
52.01	Gasket Connecting Frame
25.02	Connecting Frame
53.00	Breather Nut
25.01	Deflector
32.08	Oil Seal
54.00	Thrower
31.01	Gland Packing / Mechanical Seal
31.02	Ring Lantern
31.04	Gland
56.00	Gasket Casing
57.00	Side Plate
29.01	Frame Support
59.00	Shim
32.11	Hex. Plug

PERFORMANCE CURVES

Model : **TEP - 3 x 2.5 x 11**

Speed : **1450 rpm**

Suc x Del (in Inches) : **3 x 2.5**

Max. Impeller Ø : **260mm**

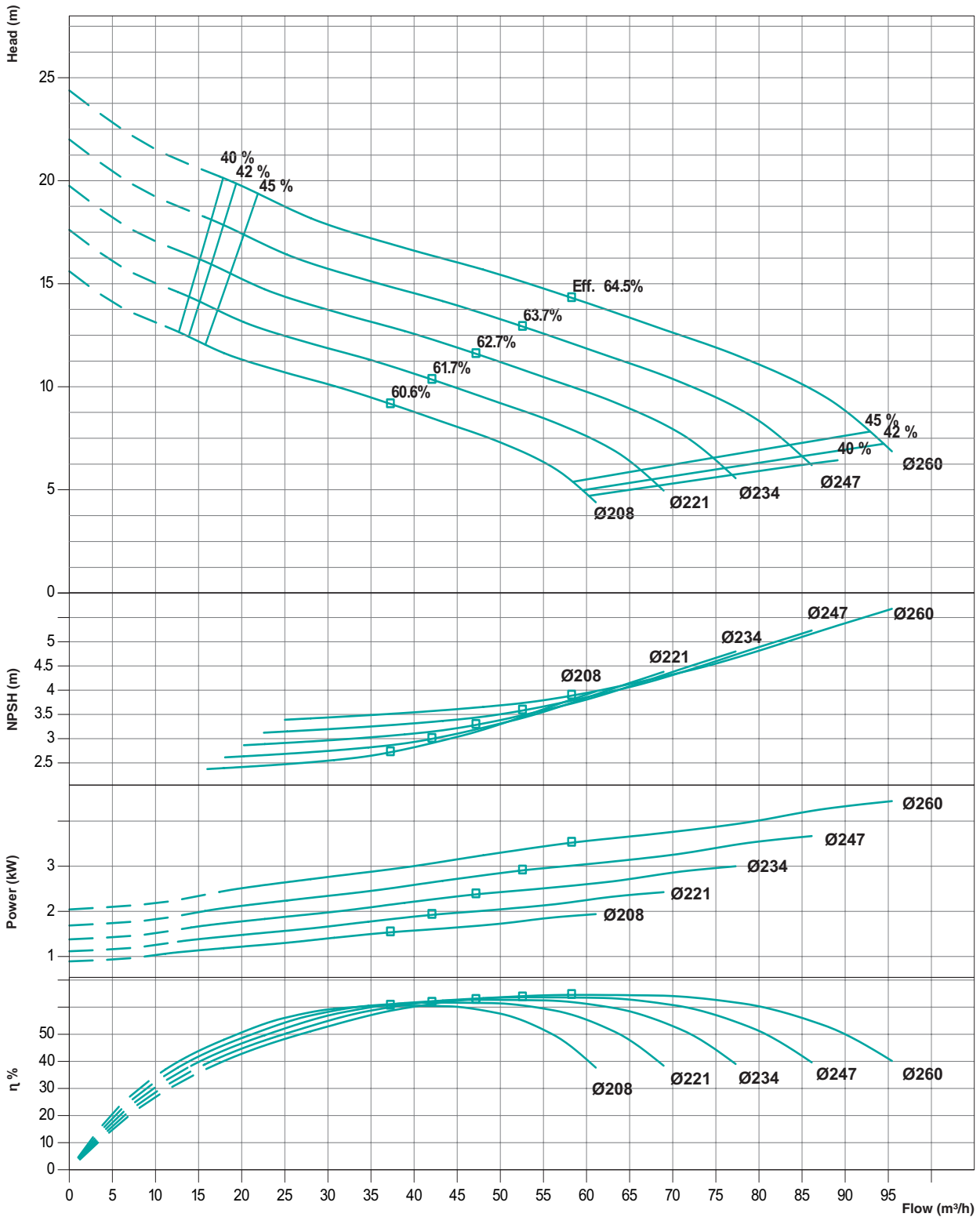

Performance curve tolerances are as per HI : 14.6 / ISO: 9906, Grade 2B

Note : Performance curve are as per specific gravity and viscosity of water.

PERFORMANCE CURVES

Model : **TEP - 3 x 3 x 10**

Speed : **1450 rpm**

Suc x Del (in Inches) : **3 x 3**

Max. Impeller Ø : **250mm**

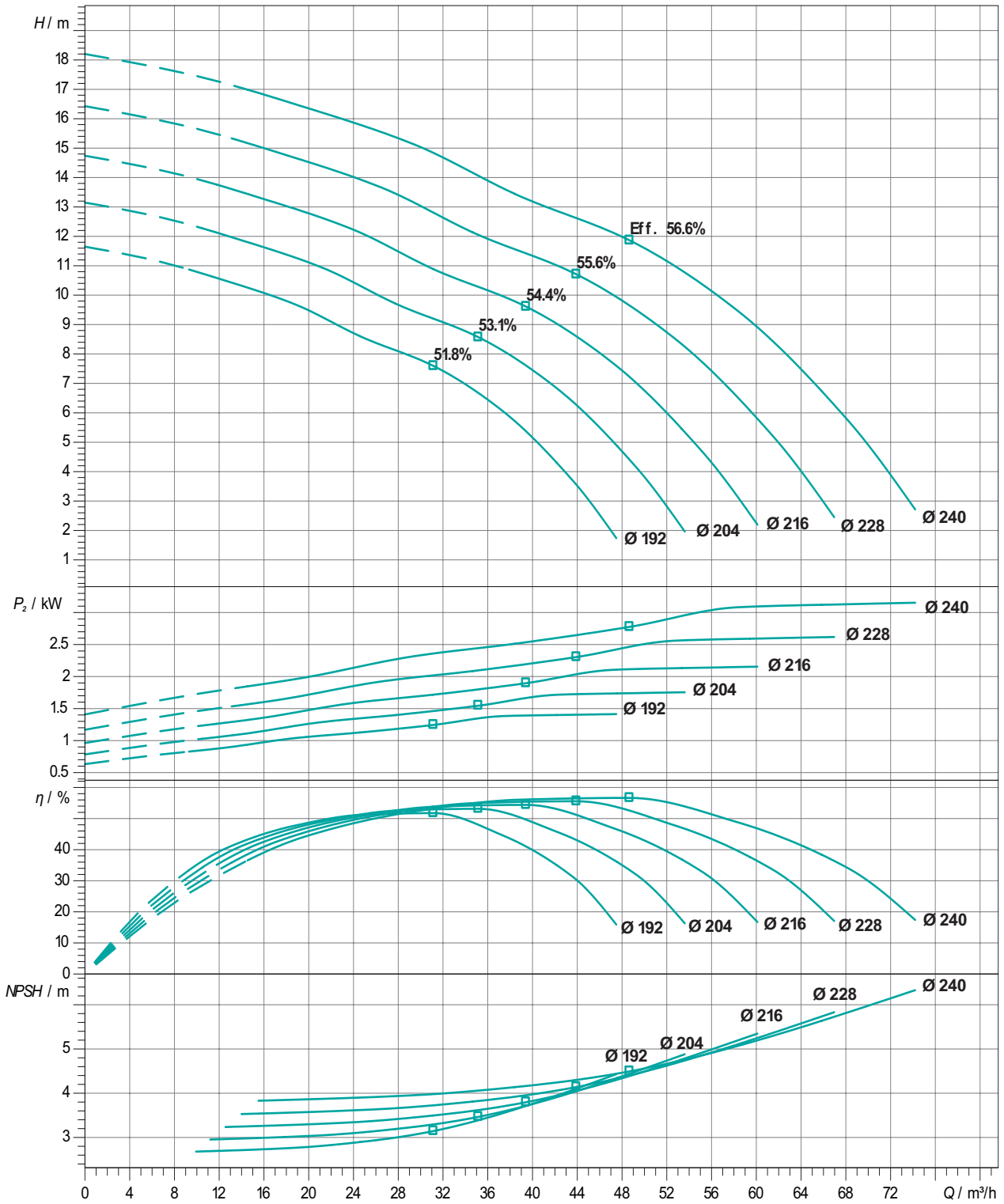

PERFORMANCE CURVES

Model : **TEP - 4 x 3 x 10.5**

Speed : **1450 rpm**

Suc x Del (in Inches) : **4 x 3**

Max. Impeller Ø : **260mm**

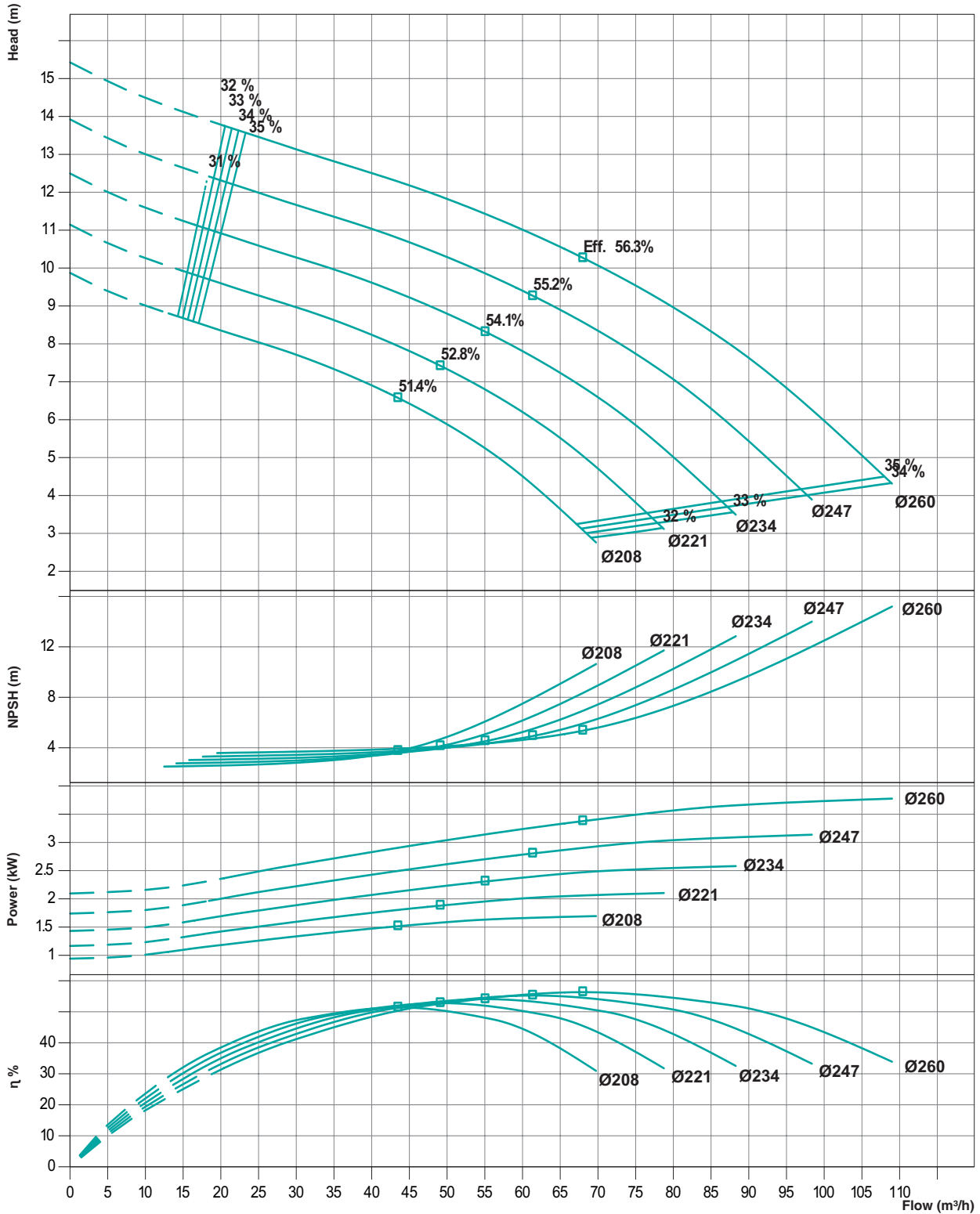

Performance curve tolerances are as per HI : 14.6 / ISO: 9906, Grade 2B

Note : Performance curve are as per specific gravity and viscosity of water.

PERFORMANCE CURVES

Model : **TEP - 4 x 3 x 11**

Speed : **1450 rpm**

Suc x Del (in Inches) : **4 x 3**

Max. Impeller Ø : **280mm**

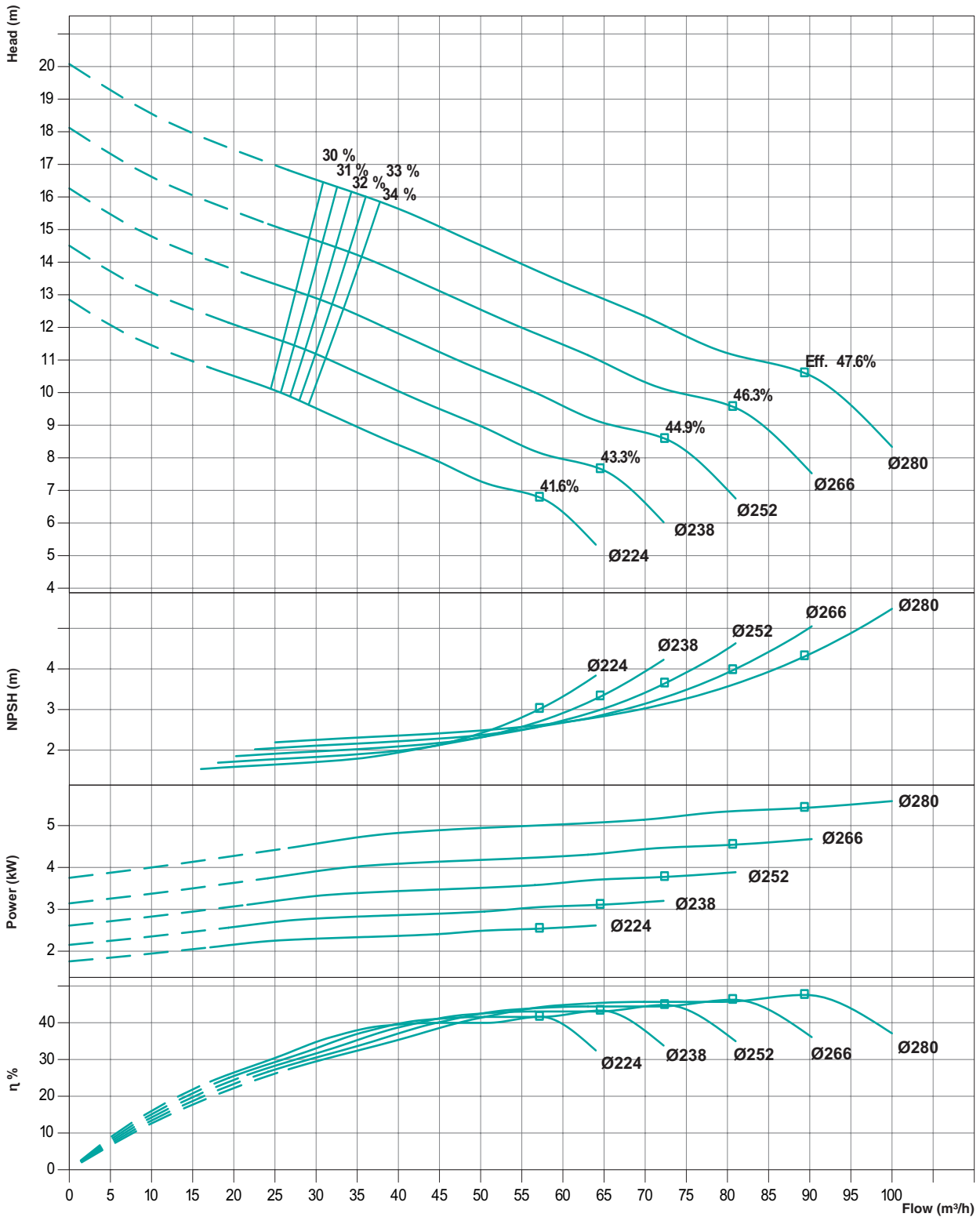

Performance curve tolerances are as per HI : 14.6 / ISO: 9906, Grade 2B

Note : Performance curve are as per specific gravity and viscosity of water.

PERFORMANCE CURVES

Model : **TEP - 6 x 3 x 14**

Speed : **720 rpm**

Suc x Del (in Inches) : **6 x 3**

Max. Impeller Ø : **355.6mm**

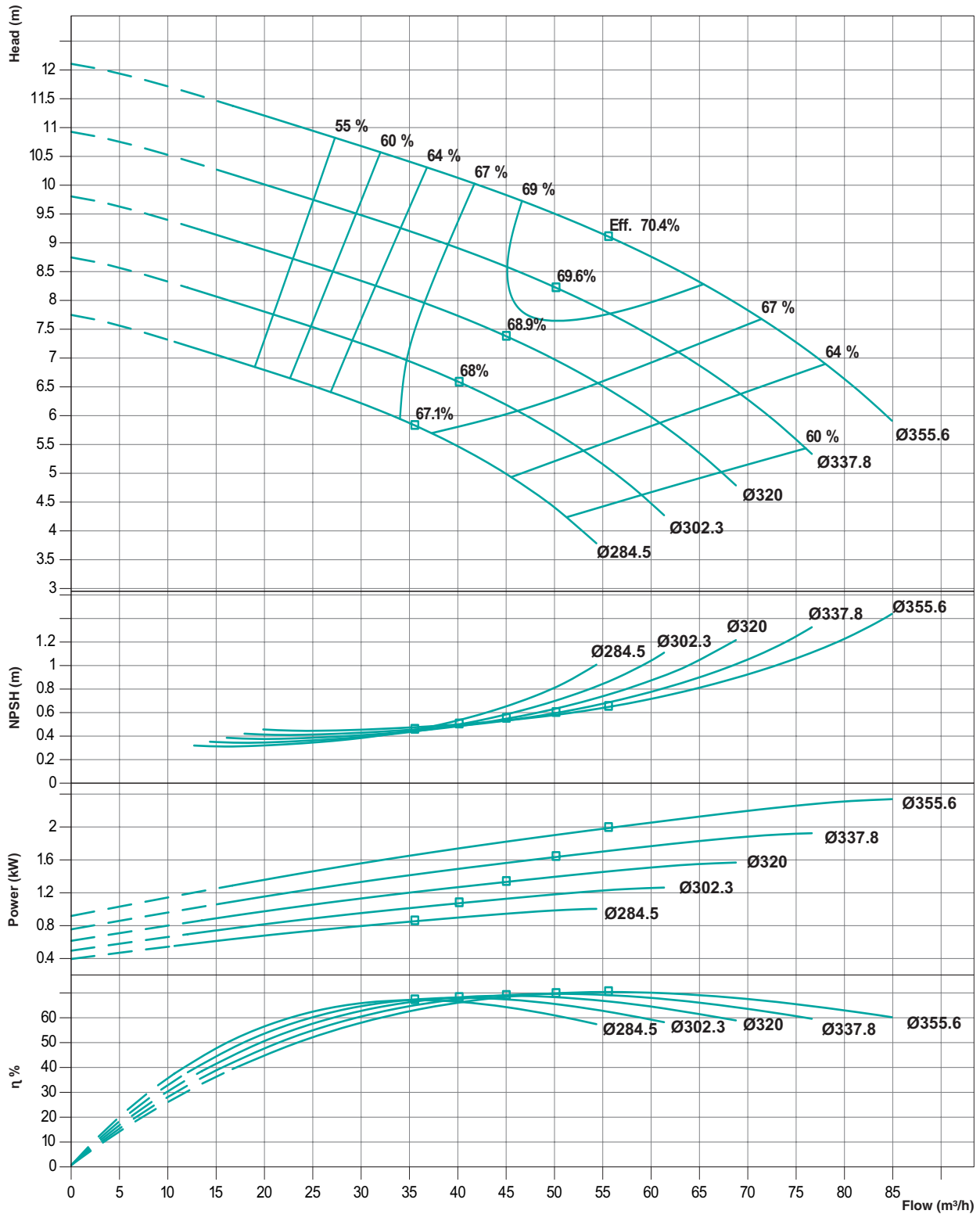

Performance curve tolerances are as per HI : 14.6 / ISO: 9906, Grade 2B

Note : Performance curve are as per specific gravity and viscosity of water.

PERFORMANCE CURVES

Model : **TEP - 6 x 3 x 14**

Speed : **960 rpm**

Suc x Del (in Inches) : **6 x 3**

Max. Impeller Ø : **355.6mm**

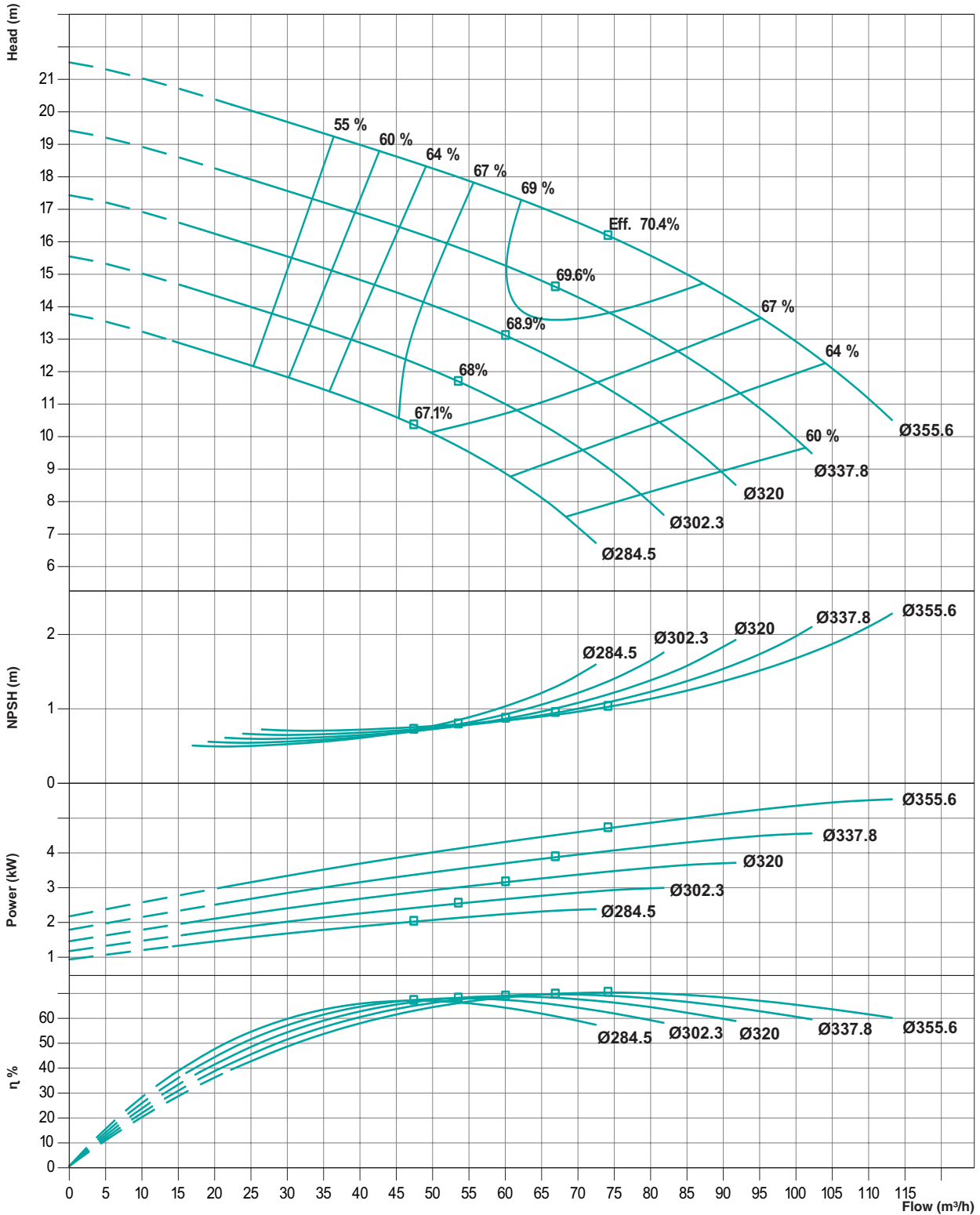

Performance curve tolerances are as per HI : 14.6 / ISO: 9906, Grade 2B

Note : Performance curve are as per specific gravity and viscosity of water.

PERFORMANCE CURVES

Model : **TEP - 6 x 3 x 14**

Speed : **1450 rpm**

Suc x Del (in Inches) : **6 x 3**

Max. Impeller Ø : **355.6mm**

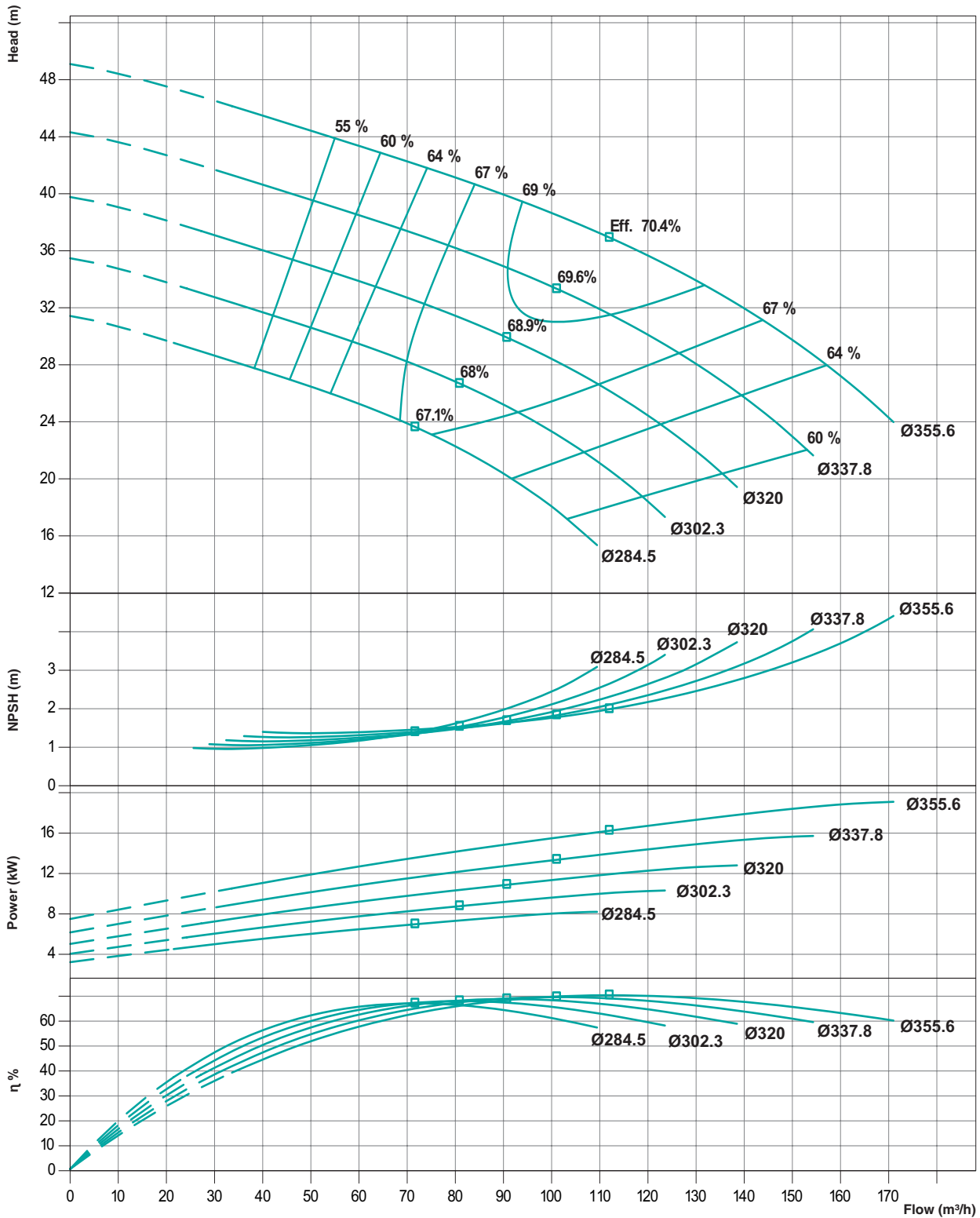

Performance curve tolerances are as per HI : 14.6 / ISO: 9906, Grade 2B

Note : Performance curve are as per specific gravity and viscosity of water.

PERFORMANCE CURVES

Model : **TEP - 6 x 4 x 14**

Speed : **720 rpm**

Suc x Del (in Inches) : **6 x 4**

Max. Impeller Ø : **355.6mm**

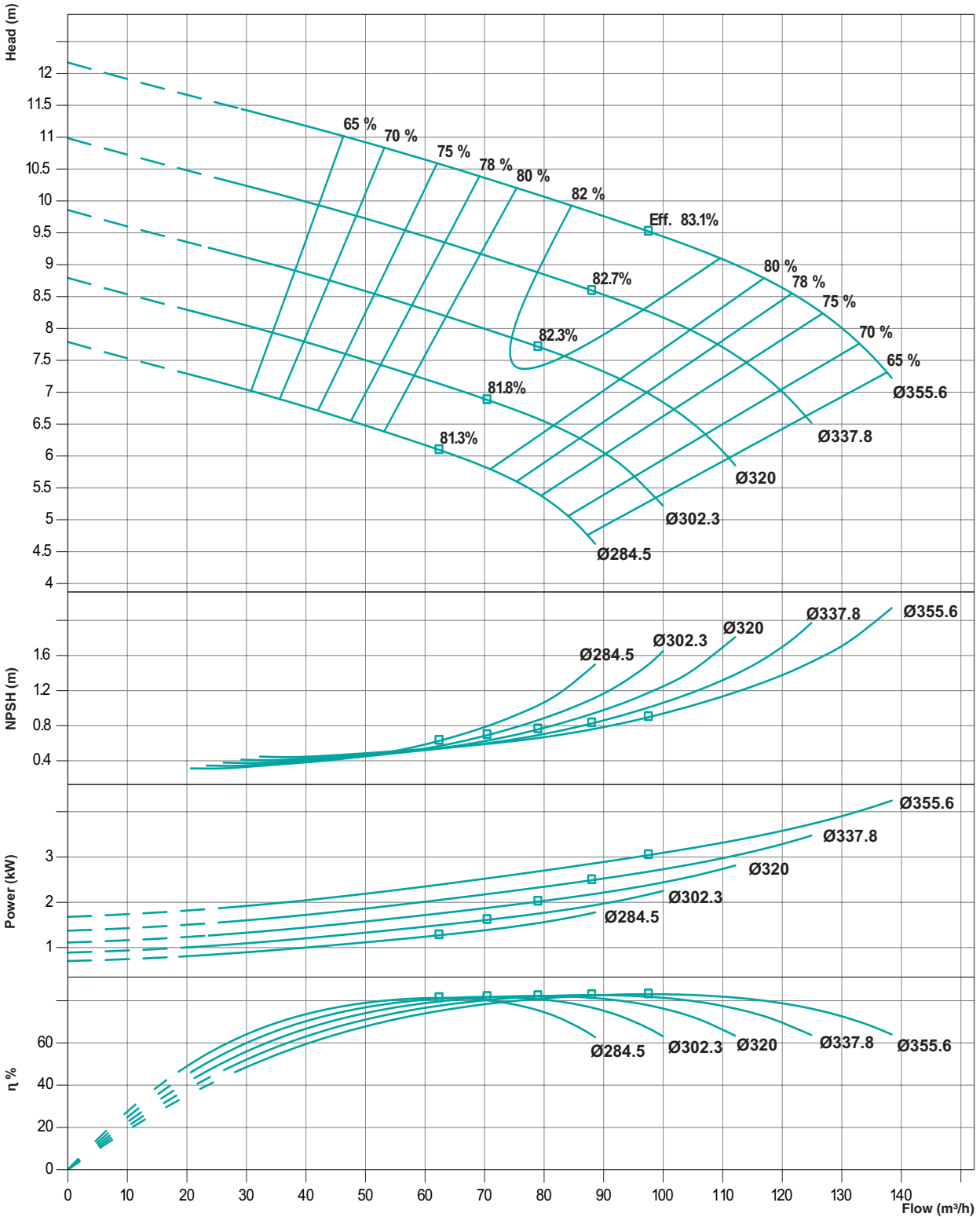

Performance curve tolerances are as per HI : 14.6 / ISO: 9906, Grade 2B

Note : Performance curve are as per specific gravity and viscosity of water.

PERFORMANCE CURVES

Model : **TEP - 6 x 4 x 14**

Speed : **960 rpm**

Suc x Del (in Inches) : **6 x 4**

Max. Impeller Ø : **355.6mm**

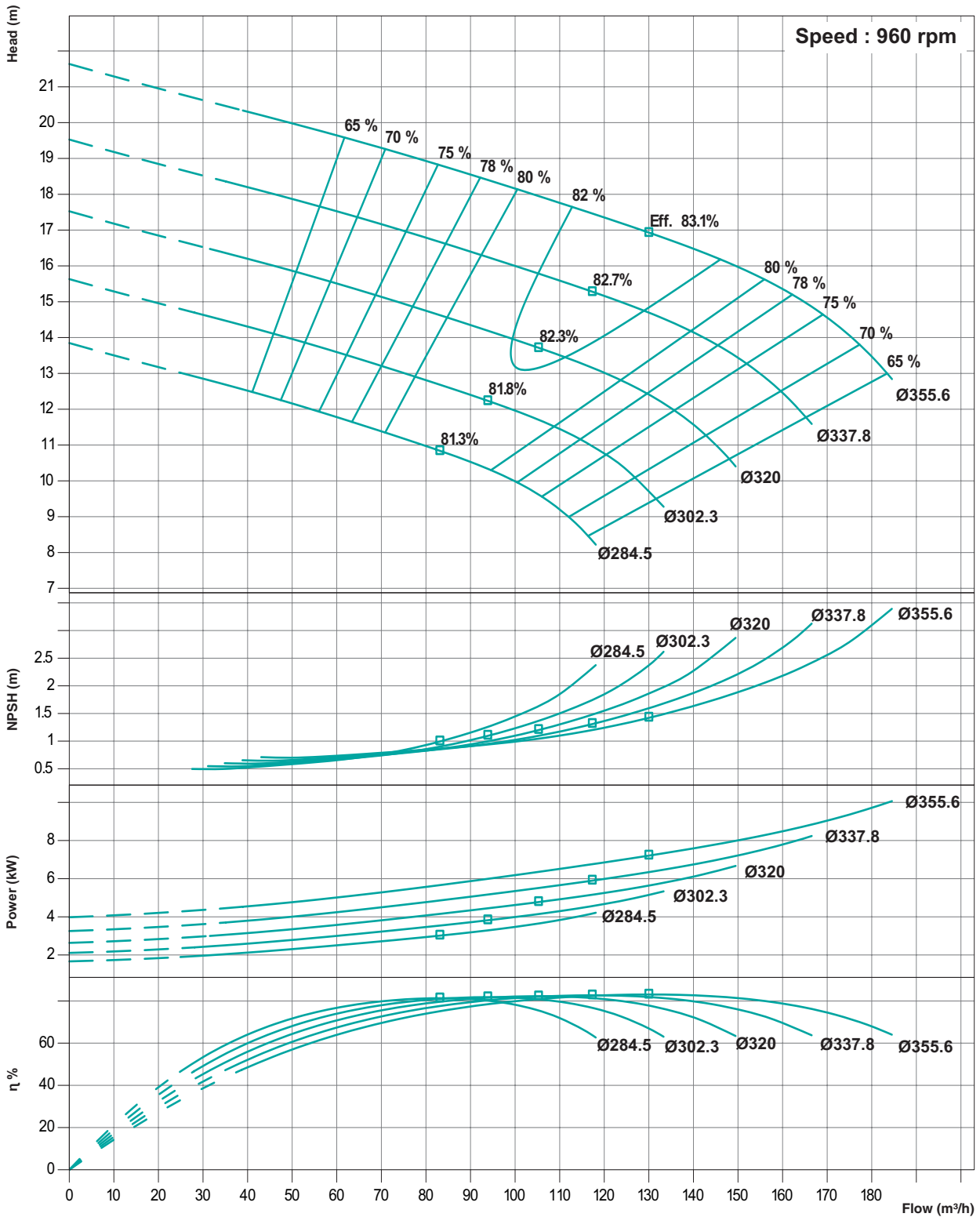

Performance curve tolerances are as per HI : 14.6 / ISO: 9906, Grade 2B

Note : Performance curve are as per specific gravity and viscosity of water.

PERFORMANCE CURVES

Model : **TEP - 6 x 4 x 14**

Speed : **1450 rpm**

Suc x Del (in Inches) : **6 x 4**

Max. Impeller Ø : **355.6mm**

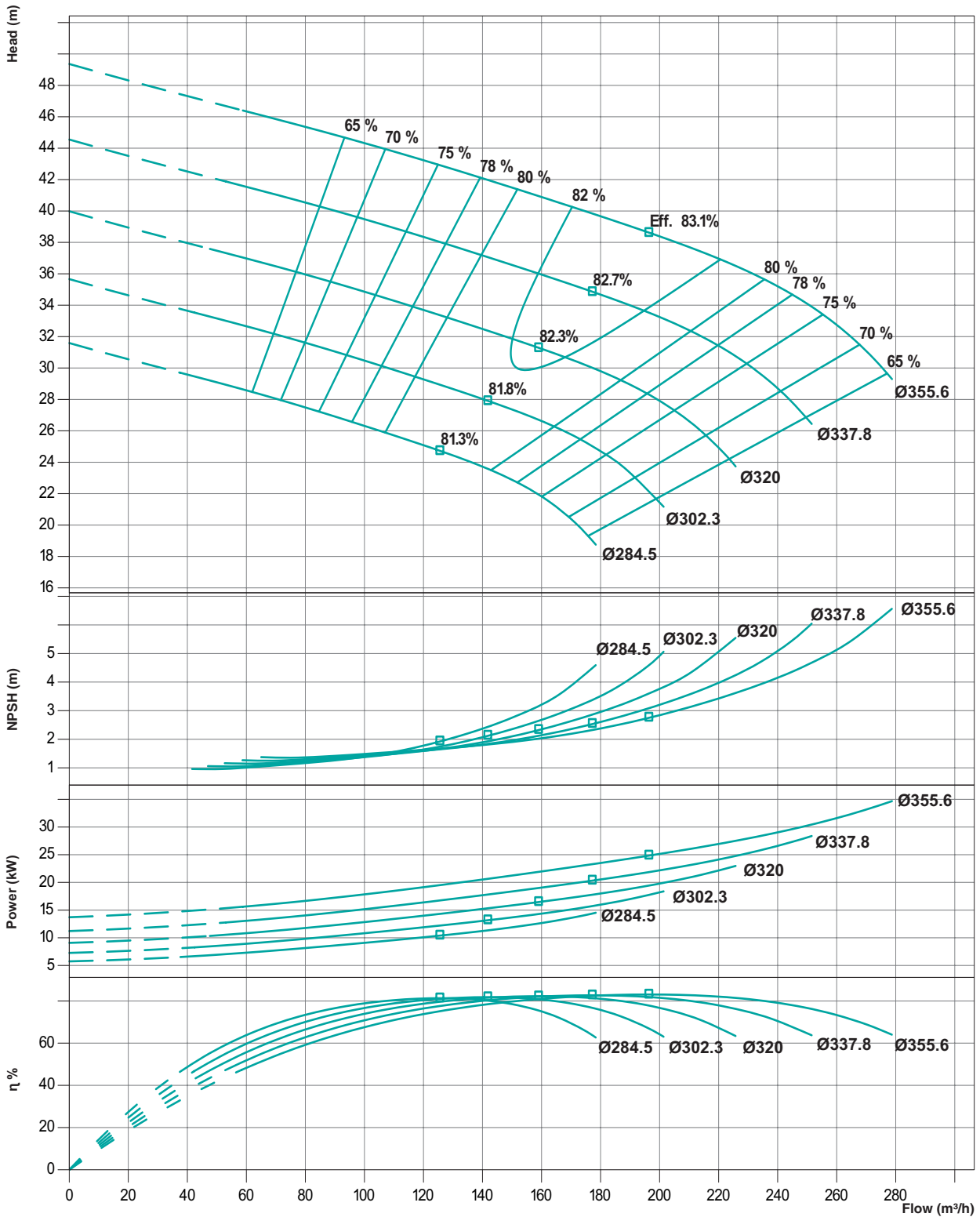

Performance curve tolerances are as per HI : 14.6 / ISO: 9906, Grade 2B

Note : Performance curve are as per specific gravity and viscosity of water.

PERFORMANCE CURVES

Model : **TEP - 8 x 4 x 17**

Speed : **720 rpm**

Suc x Del (in Inches) : **8 x 4**

Max. Impeller Ø : **430mm**

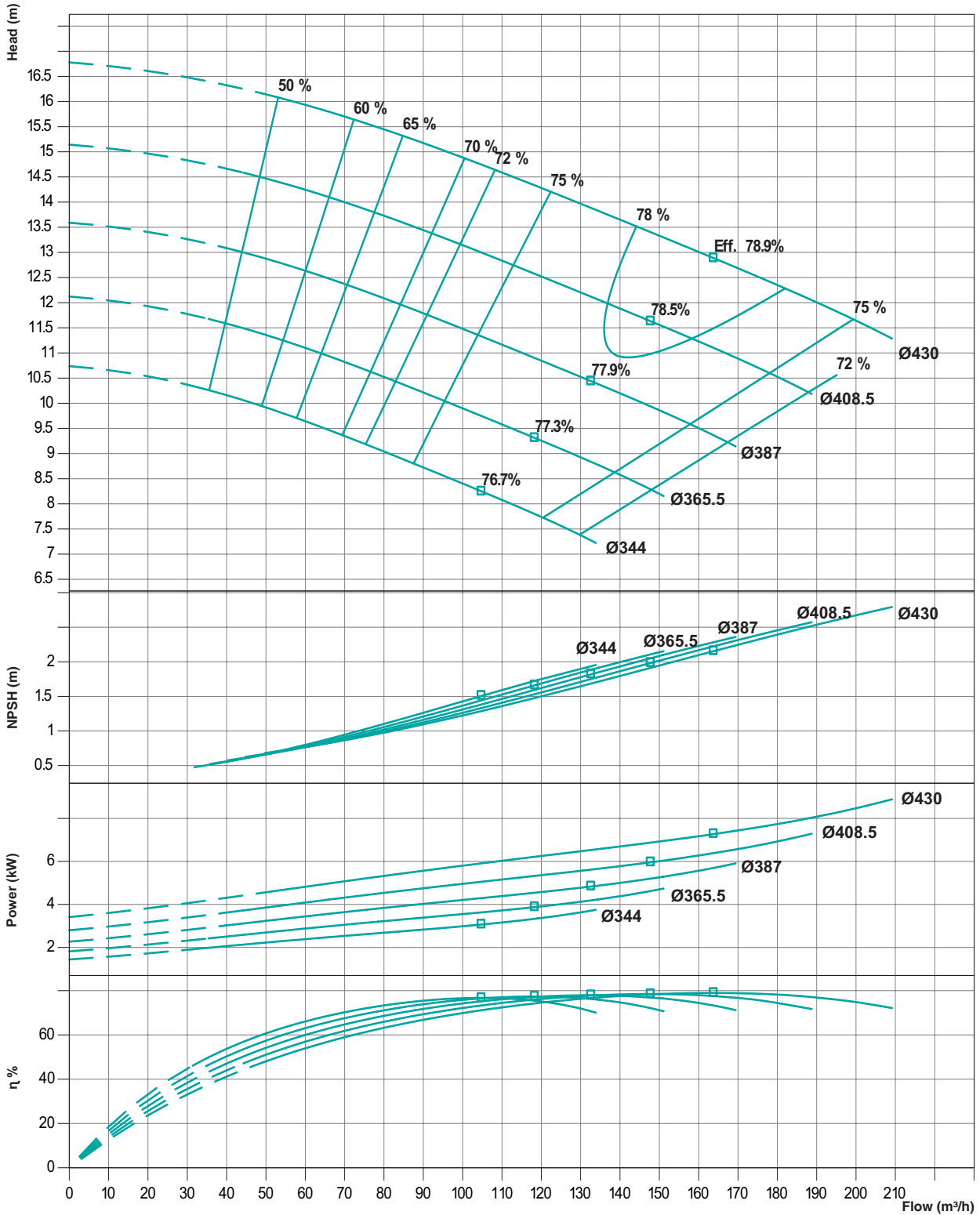

Performance curve tolerances are as per HI : 14.6 / ISO: 9906, Grade 2B

Note : Performance curve are as per specific gravity and viscosity of water.

PERFORMANCE CURVES

Model : **TEP - 8 x 4 x 17**

Speed : **960 rpm**

Suc x Del (in Inches) : **8 x 4**

Max. Impeller Ø : **430mm**

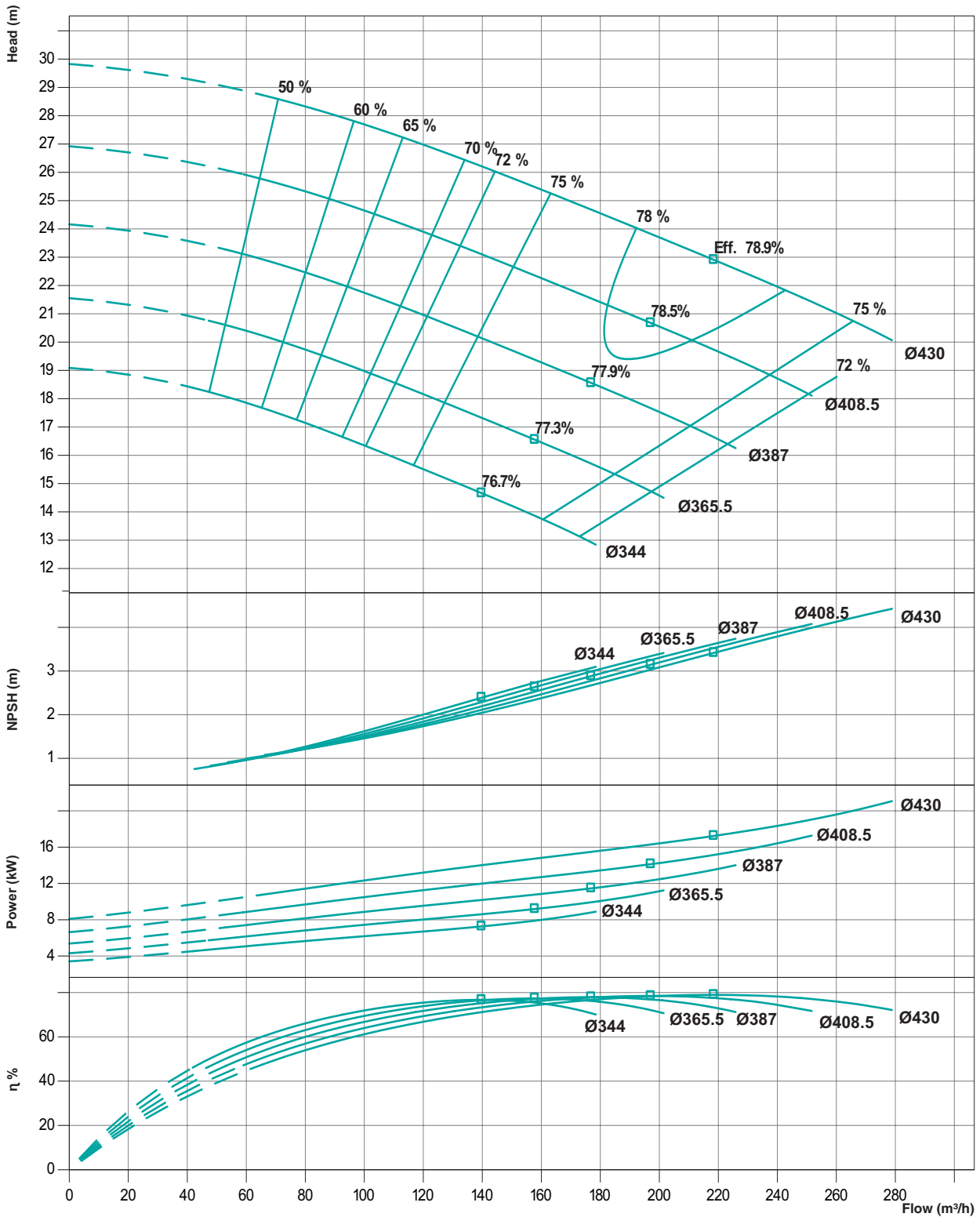

Performance curve tolerances are as per HI : 14.6 / ISO: 9906, Grade 2B

Note : Performance curve are as per specific gravity and viscosity of water.

PERFORMANCE CURVES

Model : **TEP - 8 x 4 x 17**

Speed : **1450 rpm**

Suc x Del (in Inches) : **8 x 4**

Max. Impeller Ø : **430mm**

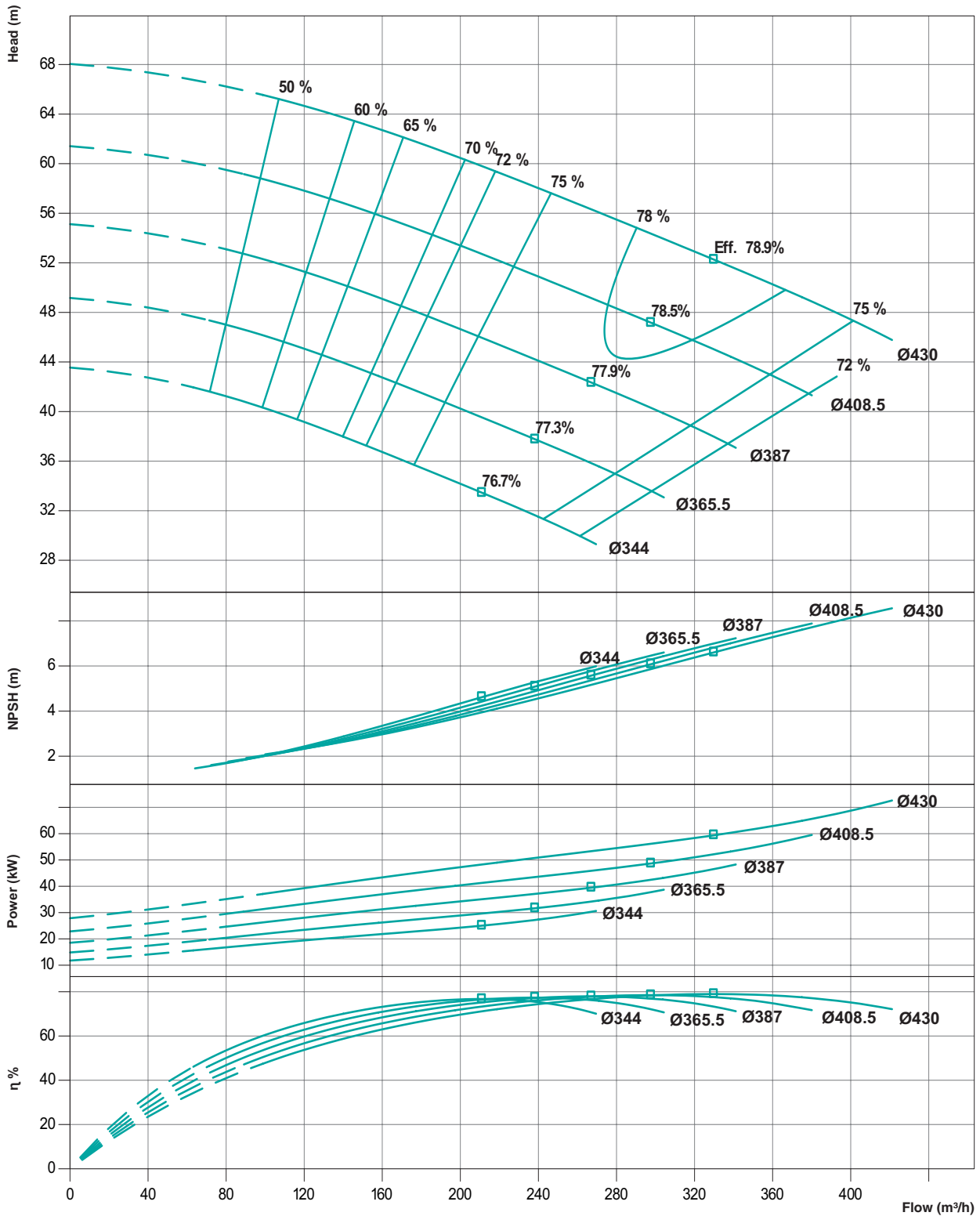

Performance curve tolerances are as per HI : 14.6 / ISO: 9906, Grade 2B

Note : Performance curve are as per specific gravity and viscosity of water.

PERFORMANCE CURVES

Model : **TEP - 8 x 5 x 17**

Speed : **1450 rpm**

Suc x Del (in Inches) : **8 x 5**

Max. Impeller Ø : **431.8mm**

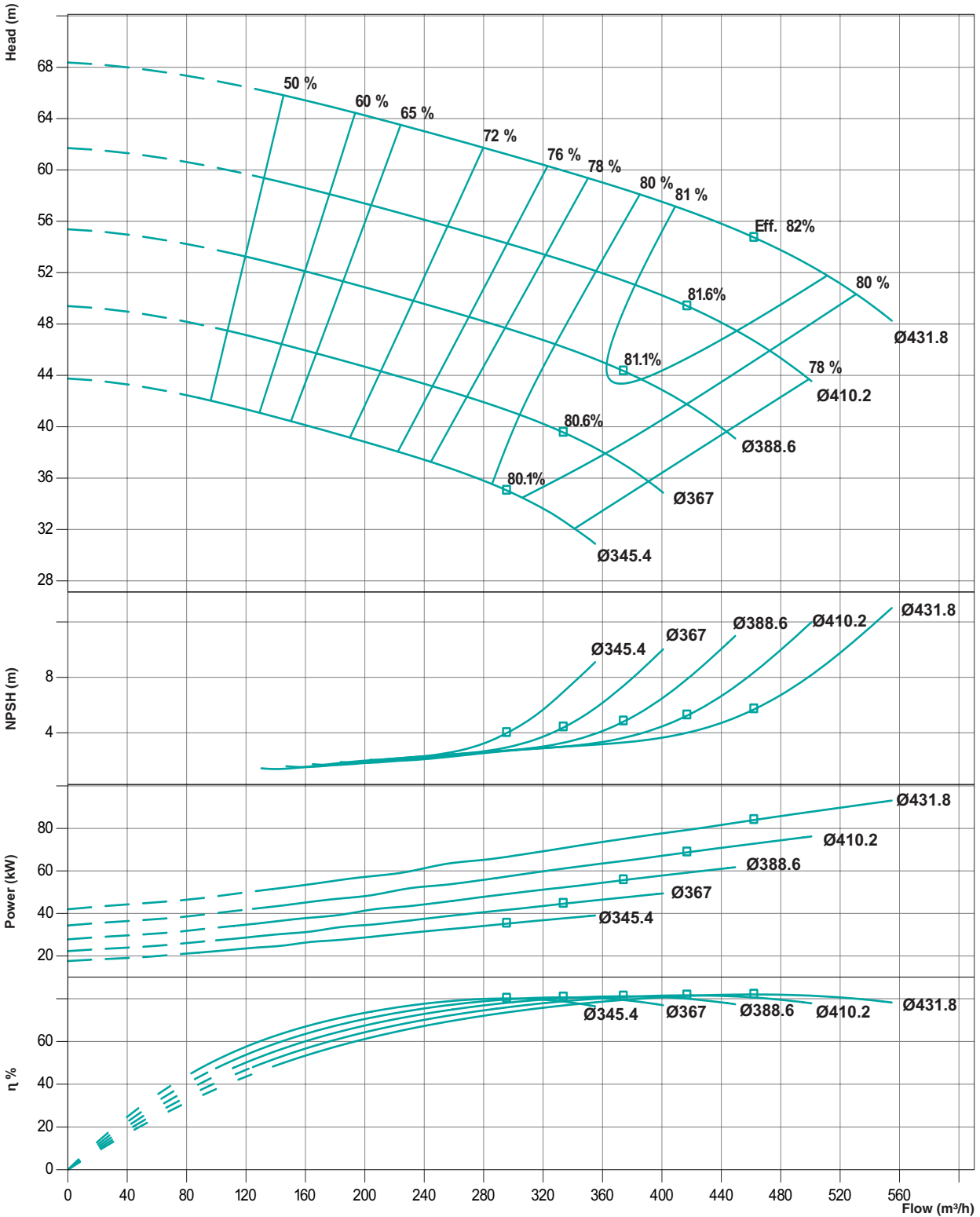

Performance curve tolerances are as per HI : 14.6 / ISO: 9906, Grade 2B

Note : Performance curve are as per specific gravity and viscosity of water.

PERFORMANCE CURVES

Model : **TEP - 8 x 6 x 17**

Speed : **720 rpm**

Suc x Del (in Inches) : **8 x 6**

Max. Impeller Ø : **431.8mm**

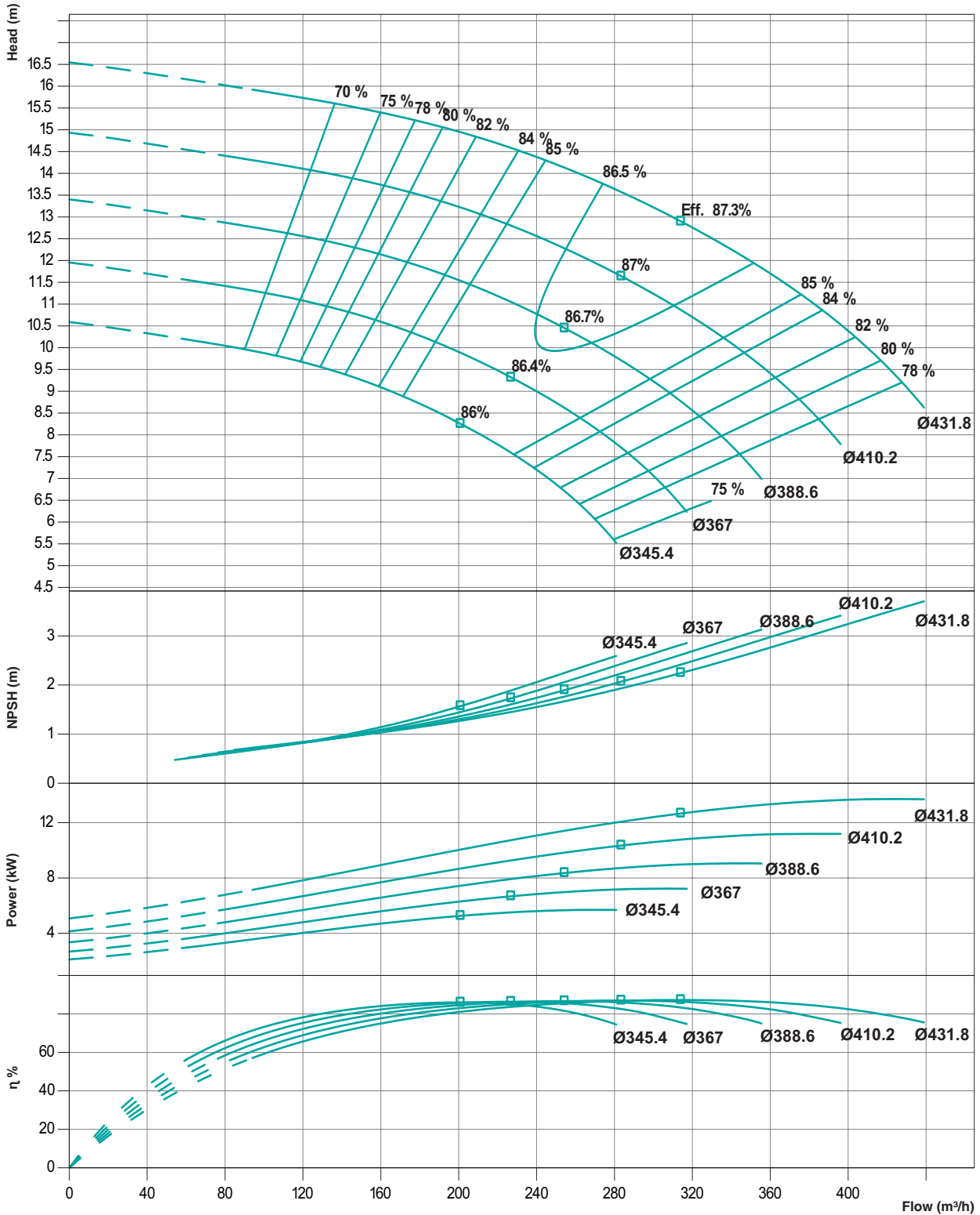

Performance curve tolerances are as per HI : 14.6 / ISO: 9906, Grade 2B

Note : Performance curve are as per specific gravity and viscosity of water.

PERFORMANCE CURVES

Model : **TEP - 8 x 6 x 17**

Speed : **960 rpm**

Suc x Del (in Inches) : **8 x 6**

Max. Impeller Ø : **431.8mm**

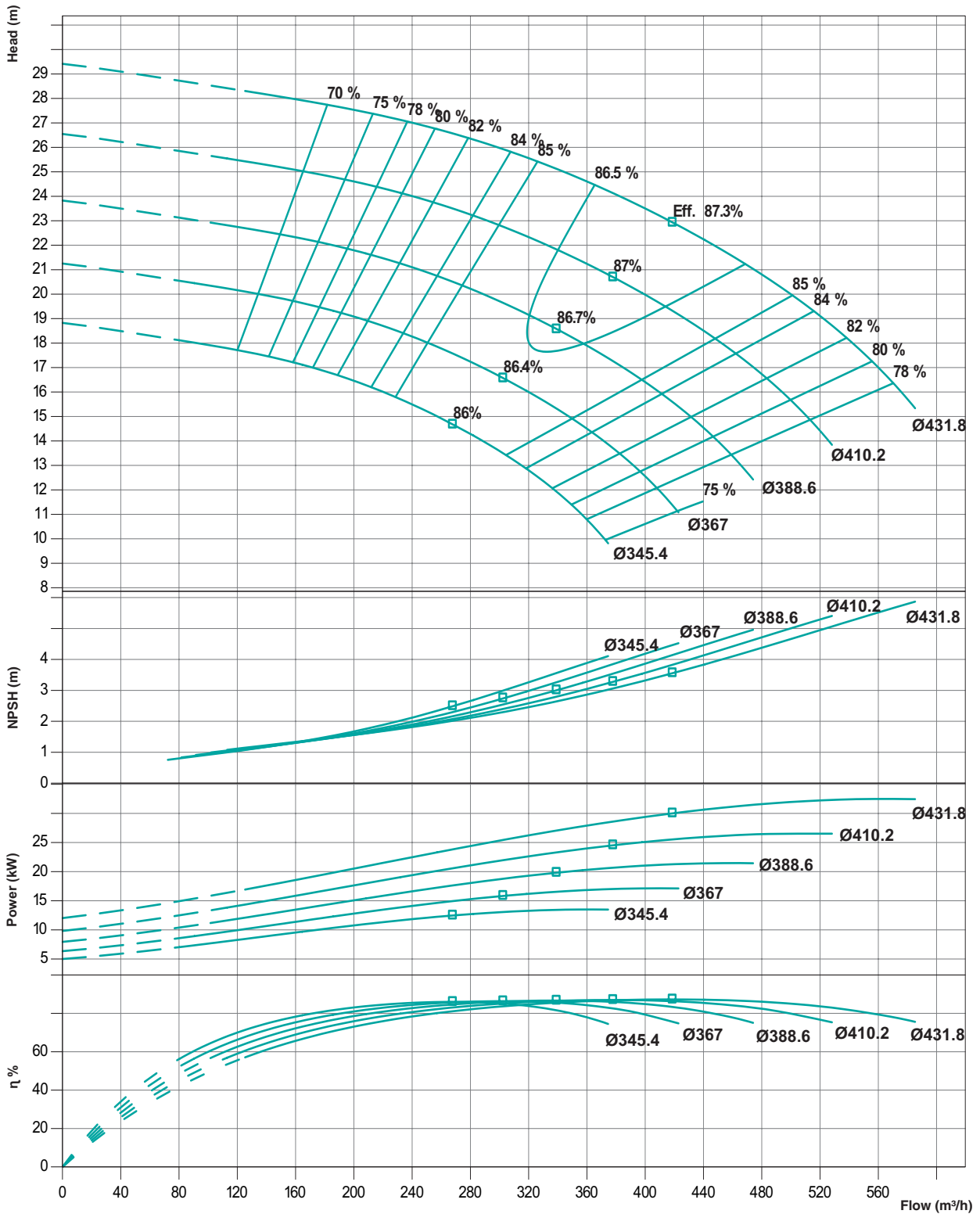

Performance curve tolerances are as per HI : 14.6 / ISO: 9906, Grade 2B

Note : Performance curve are as per specific gravity and viscosity of water.

PERFORMANCE CURVES

Model : **TEP - 8 x 6 x 17**

Speed : **1450 rpm**

Suc x Del (in Inches) : **8 x 6**

Max. Impeller Ø : **431.8mm**

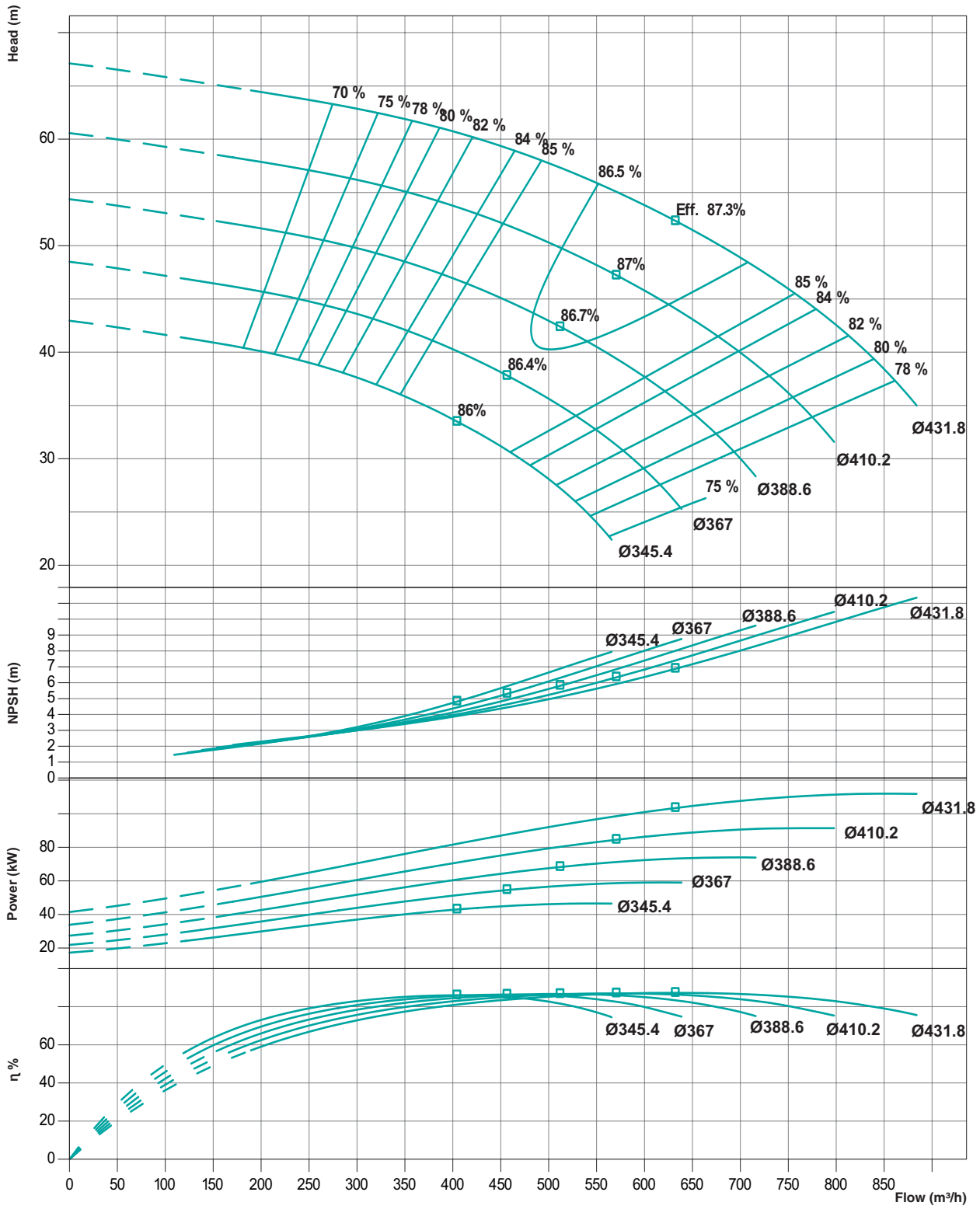

Performance curve tolerances are as per HI : 14.6 / ISO: 9906, Grade 2B

Note : Performance curve are as per specific gravity and viscosity of water.

PERFORMANCE CURVES

Model : **TEP - 8 x 6 x 21**

Speed : **720 rpm**

Suc x Del (in Inches) : **8 x 6**

Max. Impeller Ø : **533.4mm**

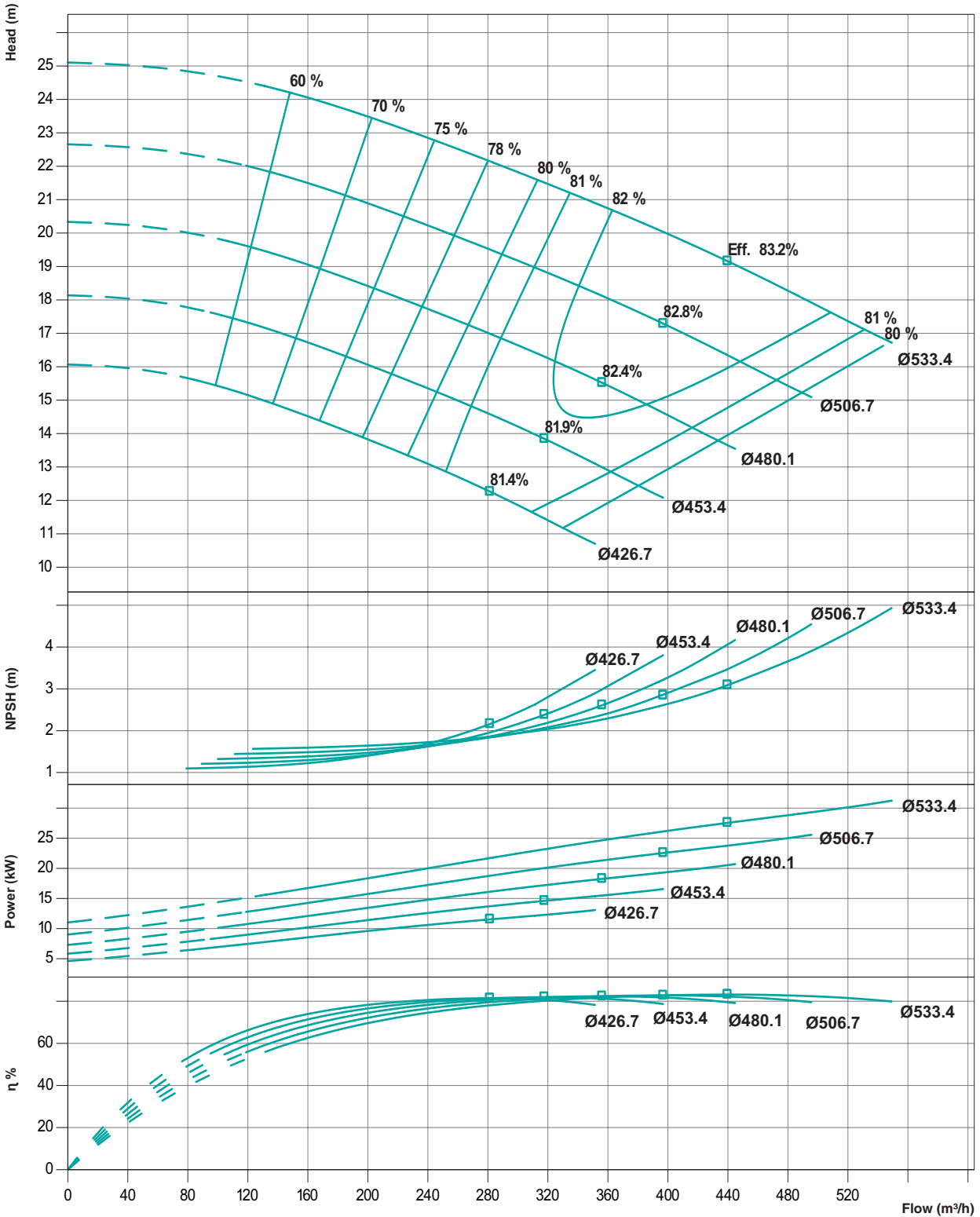

Performance curve tolerances are as per HI : 14.6 / ISO: 9906, Grade 2B

Note : Performance curve are as per specific gravity and viscosity of water.

PERFORMANCE CURVES

Model : **TEP - 8 x 6 x 21**

Speed : **960 rpm**

Suc x Del (in Inches) : **8 x 6**

Max. Impeller Ø : **533.4mm**

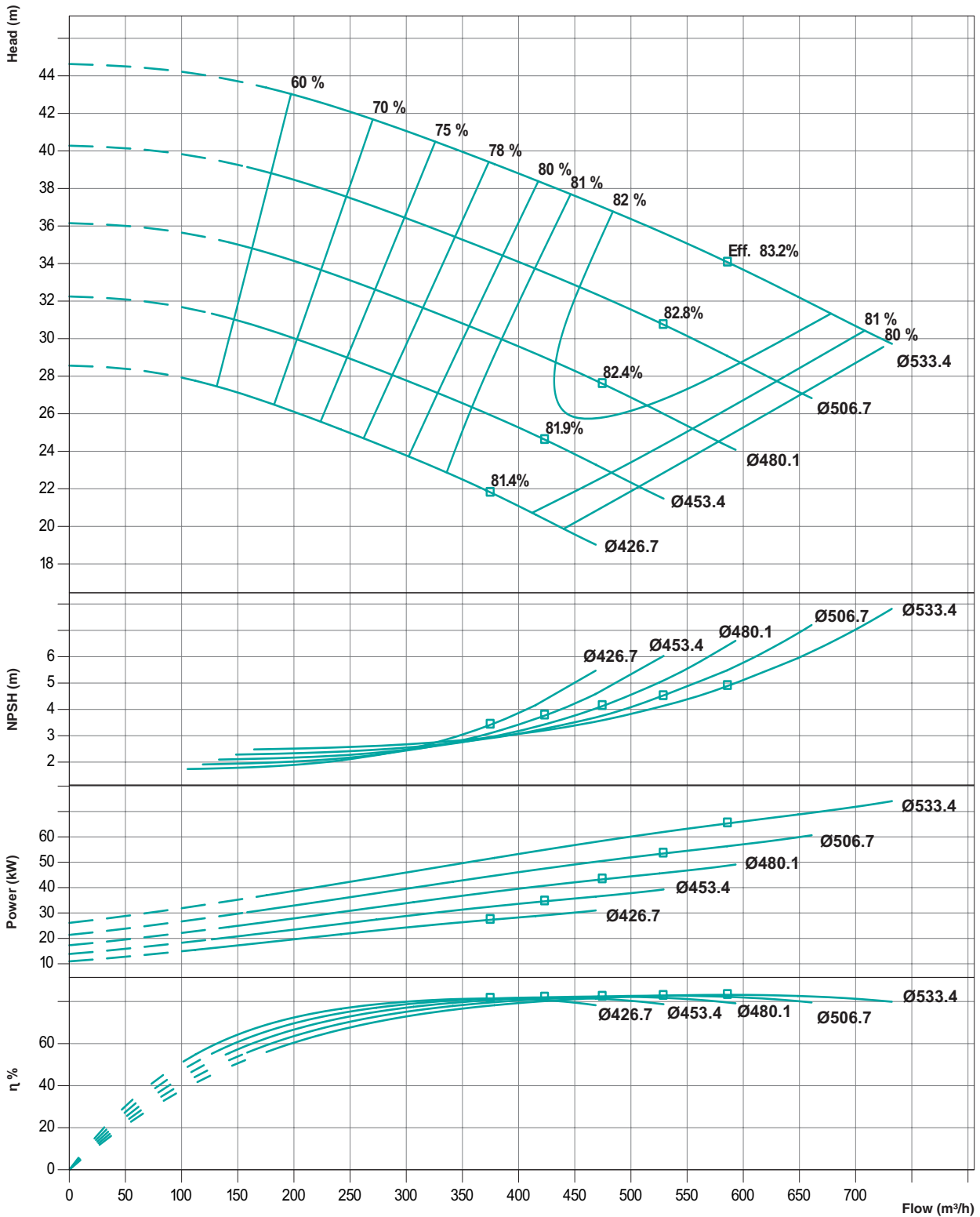

Performance curve tolerances are as per HI : 14.6 / ISO: 9906, Grade 2B

Note : Performance curve are as per specific gravity and viscosity of water.

PERFORMANCE CURVES

Model : **TEP - 8 x 6 x 21**

Speed : **1450 rpm**

Suc x Del (in Inches) : **8 x 6**

Max. Impeller Ø : **533.4mm**

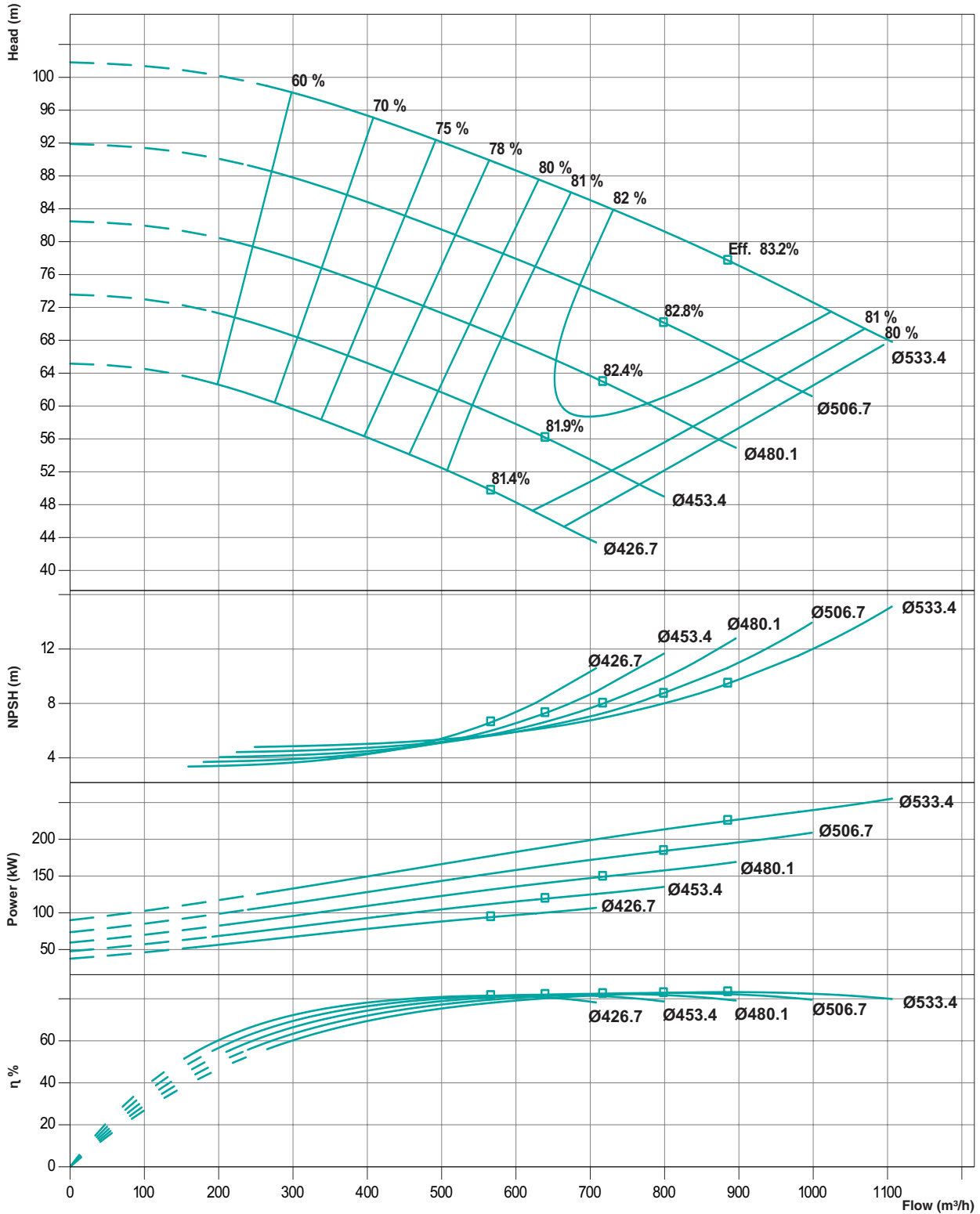

Performance curve tolerances are as per HI : 14.6 / ISO: 9906, Grade 2B

Note : Performance curve are as per specific gravity and viscosity of water.

PERFORMANCE CURVES

Model : **TEP - 10 x 8 x 17**

Speed : **720 rpm**

Suc x Del (in Inches) : **10 x 8**

Max. Impeller Ø : **431.8mm**

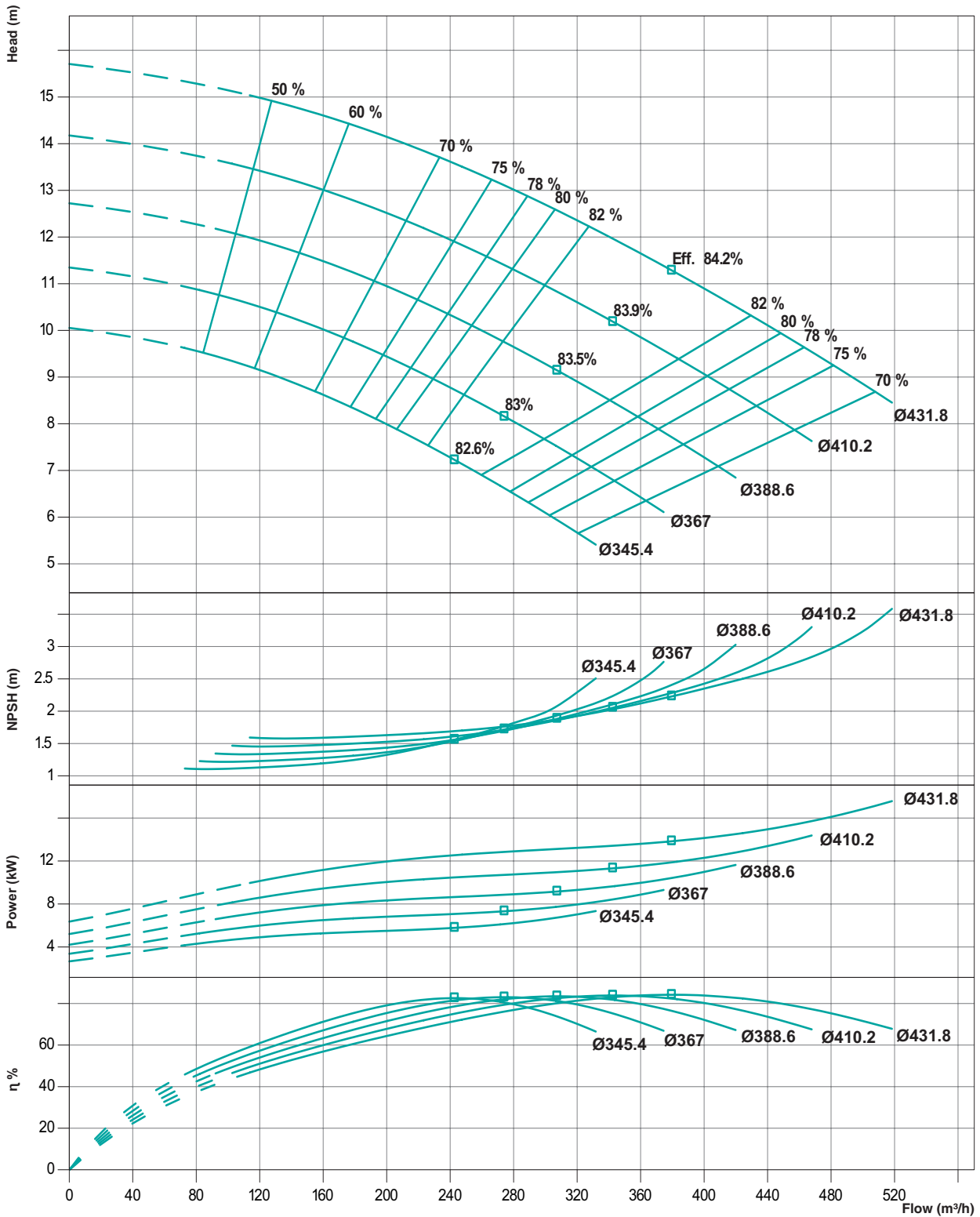

Performance curve tolerances are as per HI : 14.6 / ISO: 9906, Grade 2B

Note : Performance curve are as per specific gravity and viscosity of water.

PERFORMANCE CURVES

Model : **TEP - 10 x 8 x 17**

Speed : **960 rpm**

Suc x Del (in Inches) : **10 x 8**

Max. Impeller Ø : **431.8mm**

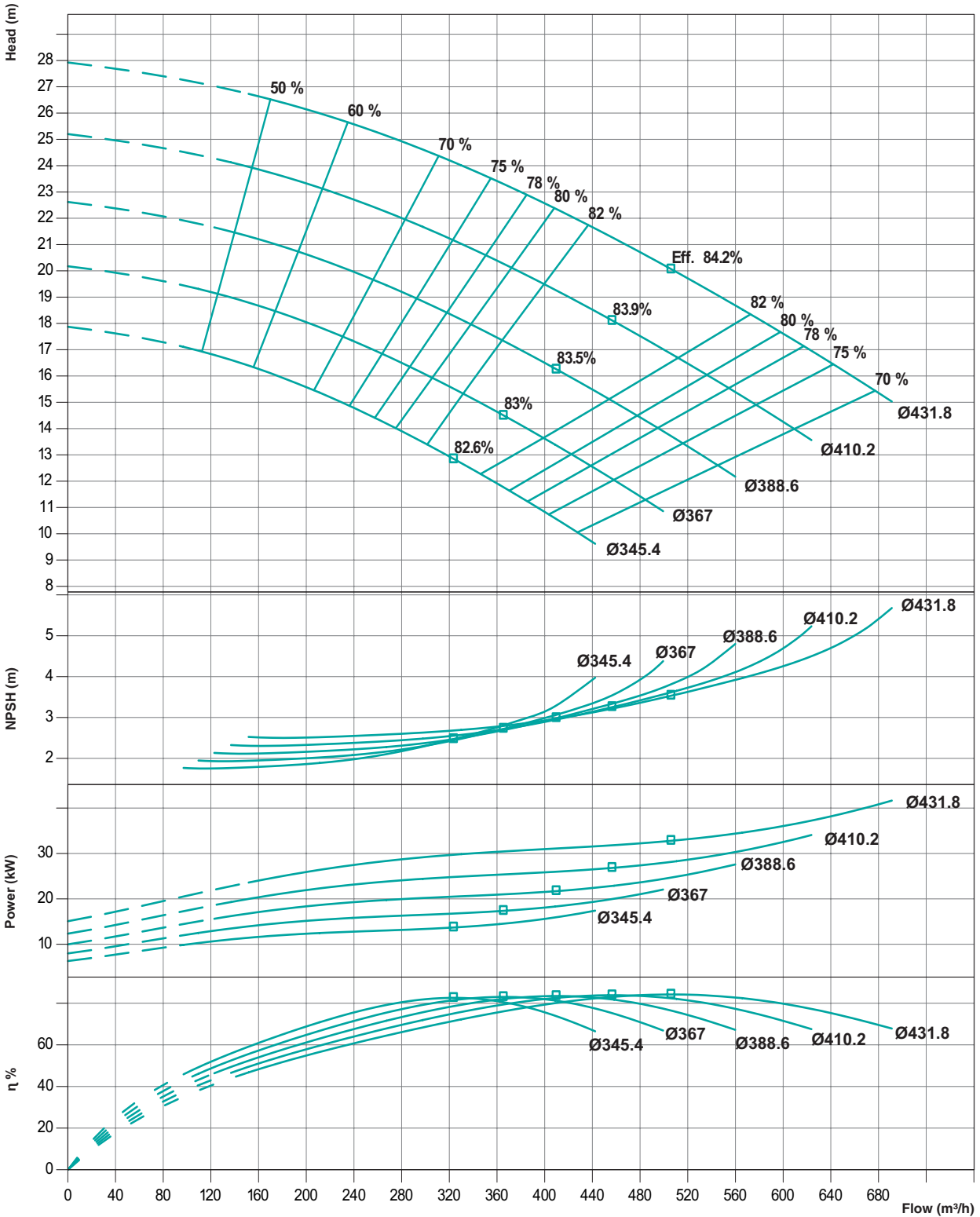

Performance curve tolerances are as per HI : 14.6 / ISO: 9906, Grade 2B

Note : Performance curve are as per specific gravity and viscosity of water.

PERFORMANCE CURVES

Model : **TEP - 10 x 8 x 17**

Speed : **1450 rpm**

Suc x Del (in Inches) : **10 x 8**

Max. Impeller Ø : **431.8mm**

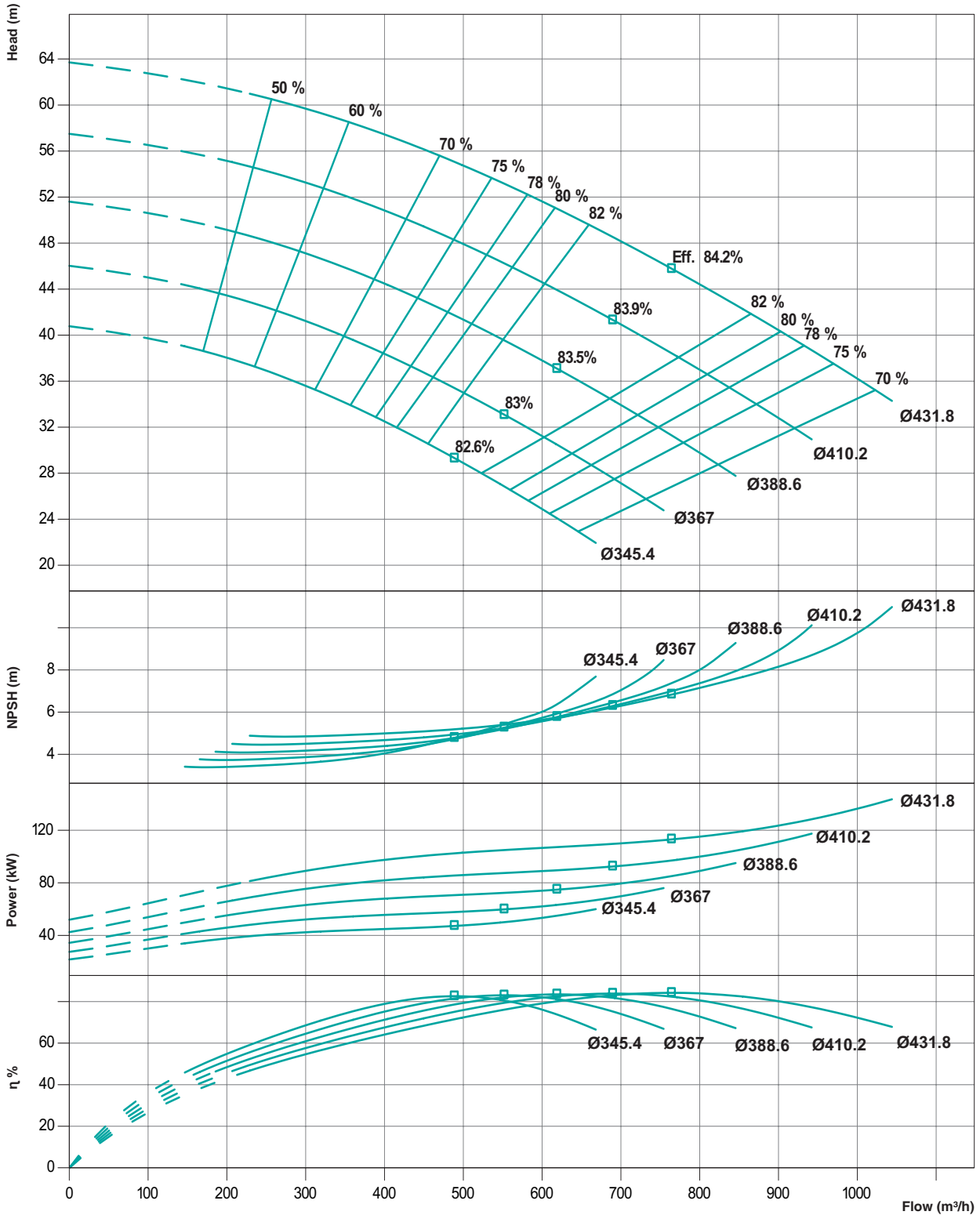

Performance curve tolerances are as per HI : 14.6 / ISO: 9906, Grade 2B

Note : Performance curve are as per specific gravity and viscosity of water.

PERFORMANCE CURVES

Model : **TEP - 10 x 8 x 21**

Speed : **720 rpm**

Suc x Del (in Inches) : **10 x 8**

Max. Impeller Ø : **533mm**

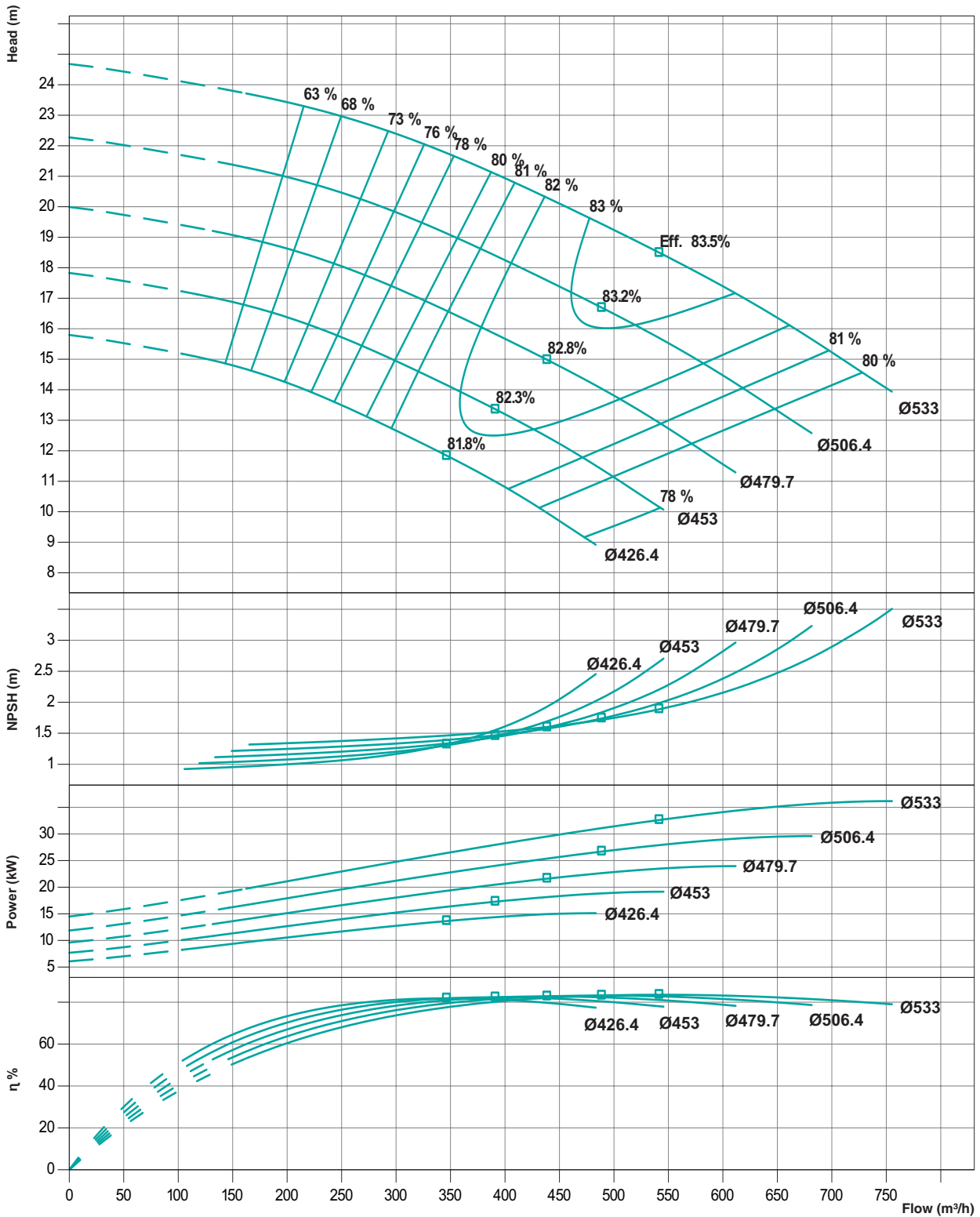

Performance curve tolerances are as per HI : 14.6 / ISO: 9906, Grade 2B

Note : Performance curve are as per specific gravity and viscosity of water.

PERFORMANCE CURVES

Model : **TEP - 10 x 8 x 21**

Speed : **960 rpm**

Suc x Del (in Inches) : **10 x 8**

Max. Impeller Ø : **533mm**

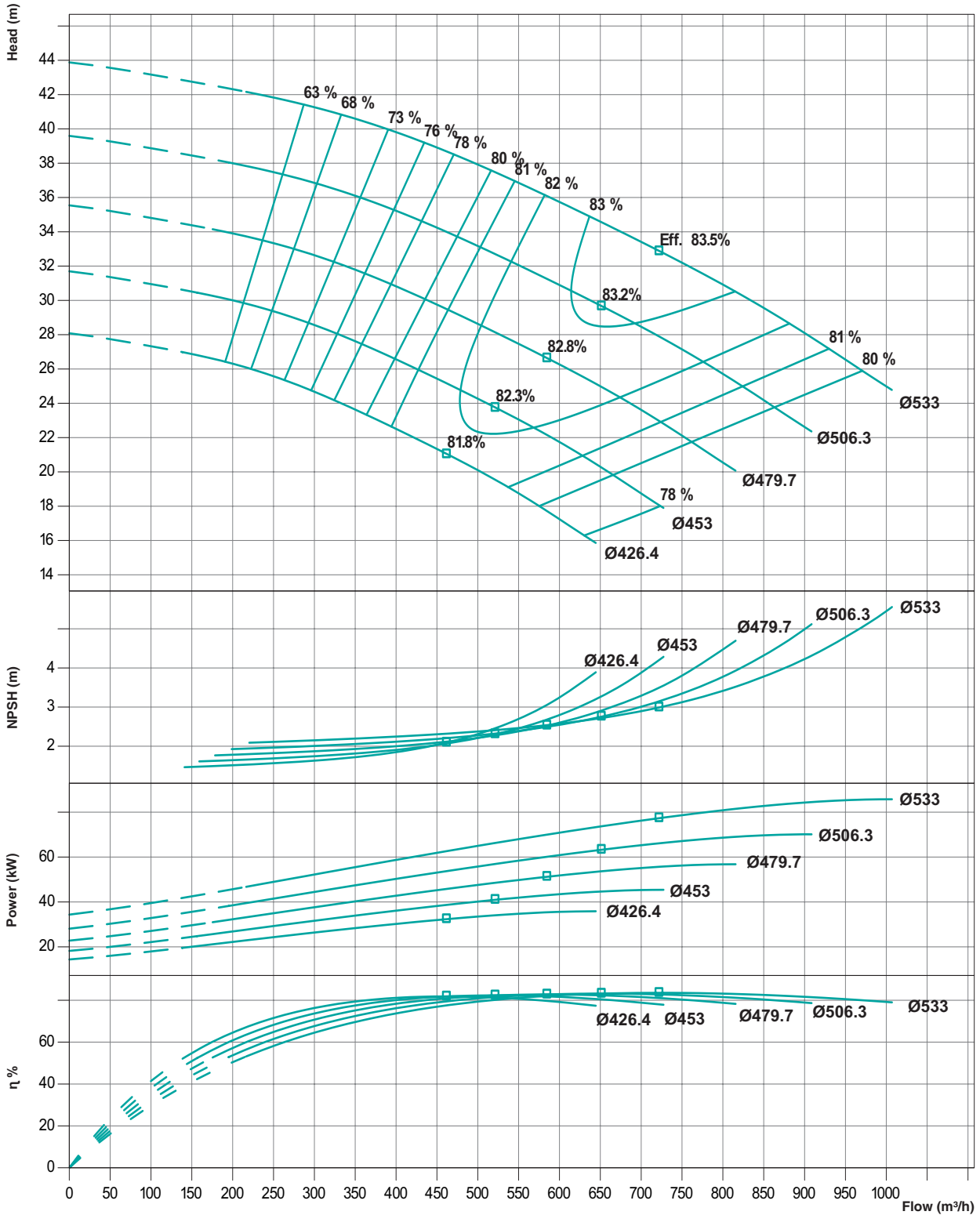

Performance curve tolerances are as per HI : 14.6 / ISO: 9906, Grade 2B

Note : Performance curve are as per specific gravity and viscosity of water.

PERFORMANCE CURVES

Model : **TEP - 10 x 8 x 21**

Speed : **1450 rpm**

Suc x Del (in Inches) : **10 x 8**

Max. Impeller Ø : **533mm**

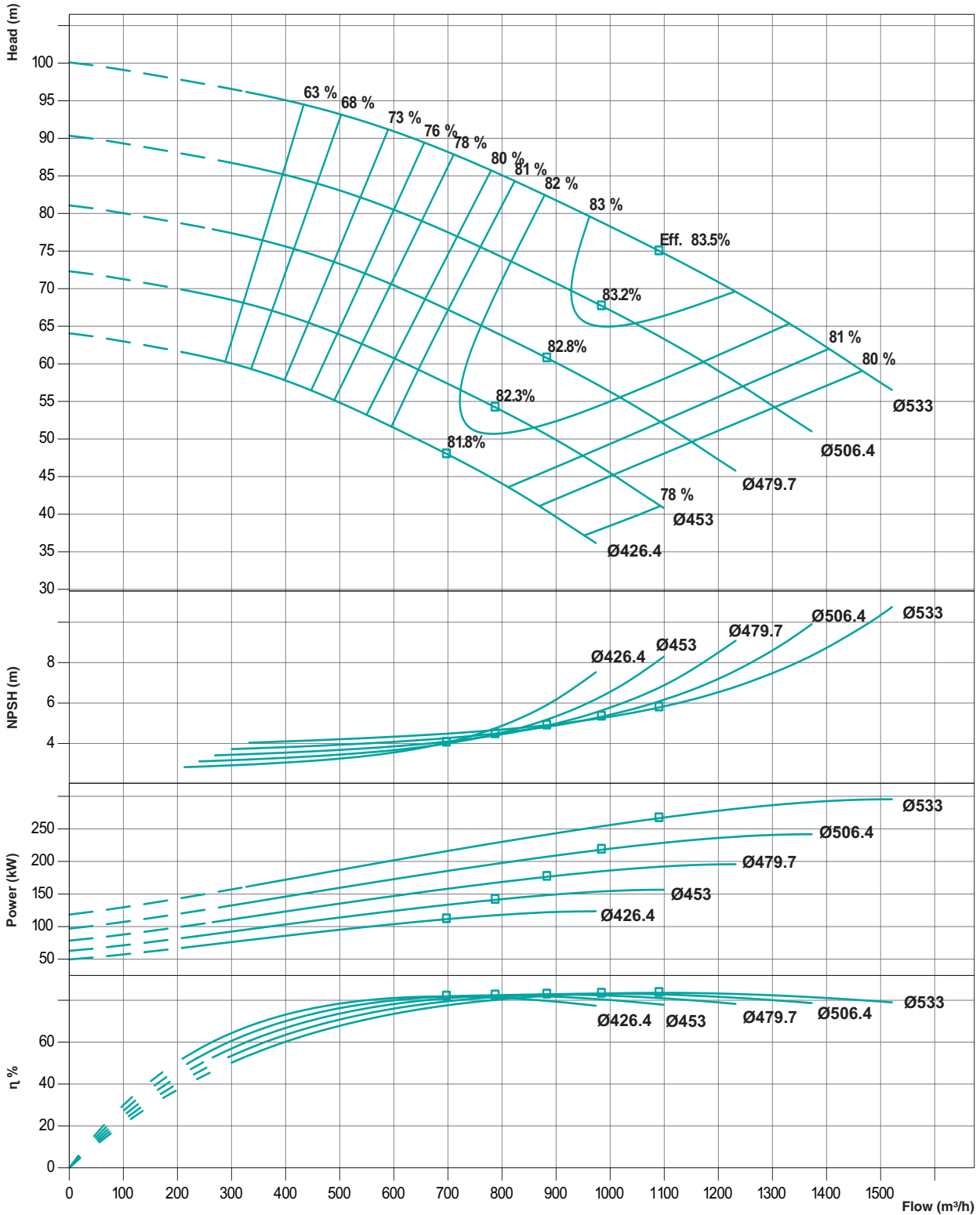

Performance curve tolerances are as per HI : 14.6 / ISO: 9906, Grade 2B

Note : Performance curve are as per specific gravity and viscosity of water.

PERFORMANCE CURVES

Model : **TEP - 12 x 10 x 17**

Speed : **720 rpm**

Suc x Del (in Inches) : **12 x 10**

Max. Impeller Ø : **430mm**

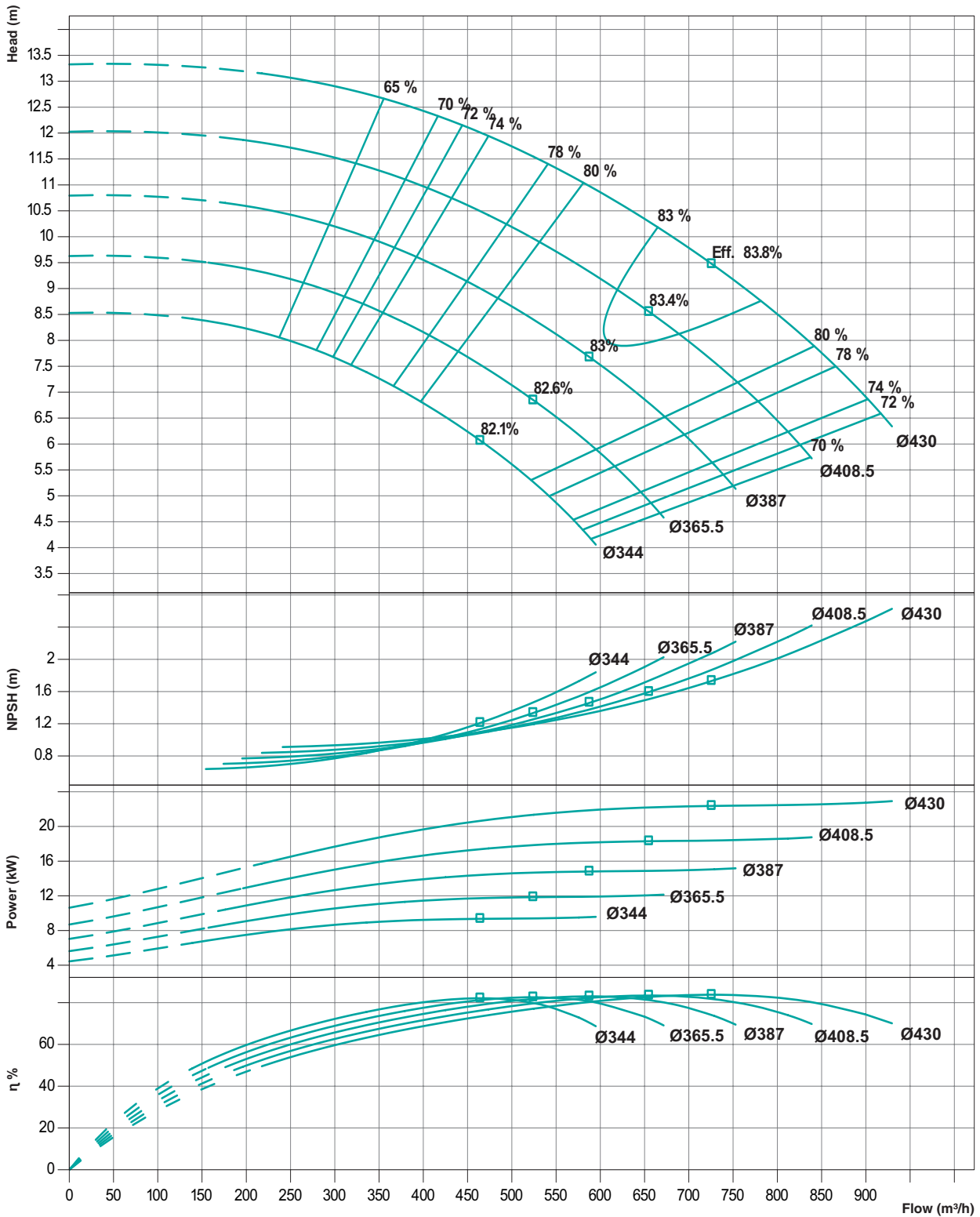

Performance curve tolerances are as per HI : 14.6 / ISO: 9906, Grade 2B

Note : Performance curve are as per specific gravity and viscosity of water.

PERFORMANCE CURVES

Model : **TEP - 12 x 10 x 17**

Speed : **960 rpm**

Suc x Del (in Inches) : **12 x 10**

Max. Impeller Ø : **430mm**

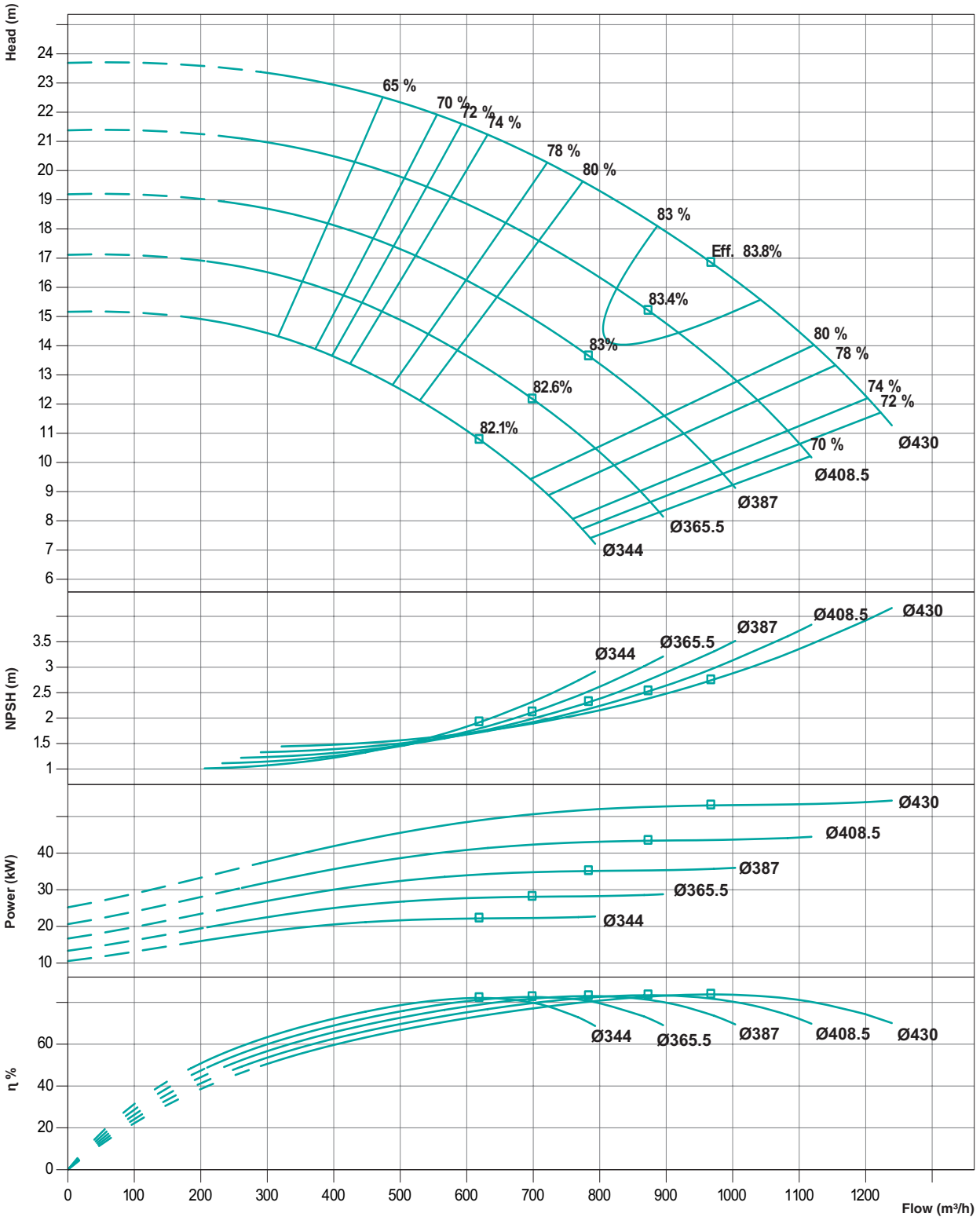

Performance curve tolerances are as per HI : 14.6 / ISO: 9906, Grade 2B

Note : Performance curve are as per specific gravity and viscosity of water.

PERFORMANCE CURVES

Model : **TEP - 12 x 10 x 17**

Speed : **1450 rpm**

Suc x Del (in Inches) : **12 x 10**

Max. Impeller Ø : **430mm**

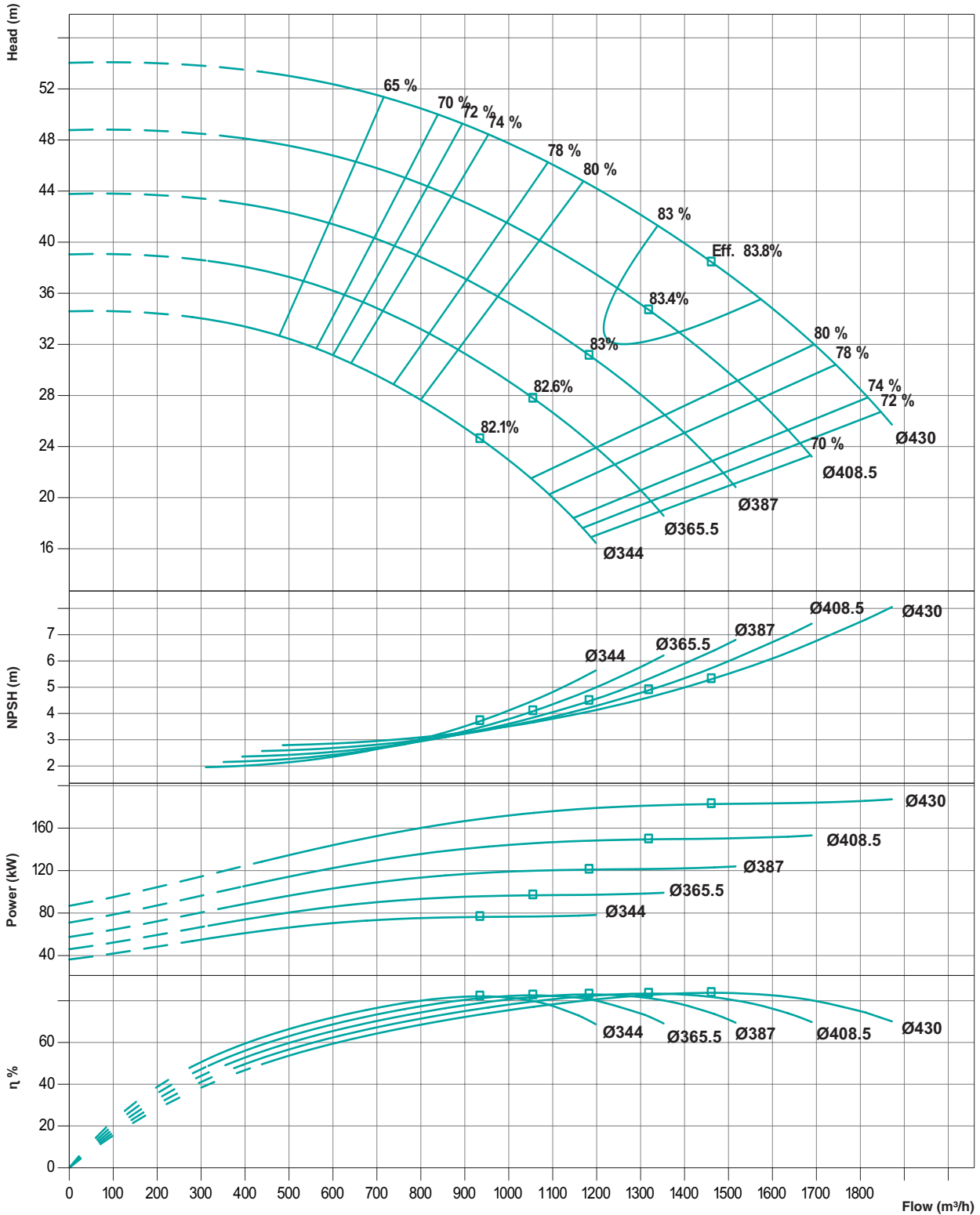

Performance curve tolerances are as per HI : 14.6 / ISO: 9906, Grade 2B

Note : Performance curve are as per specific gravity and viscosity of water.

PERFORMANCE CURVES

Model : **TEP - 14 x 12 x 21**

Speed : **720 rpm**

Suc x Del (in Inches) : **14 x 12**

Max. Impeller Ø : **533.4mm**

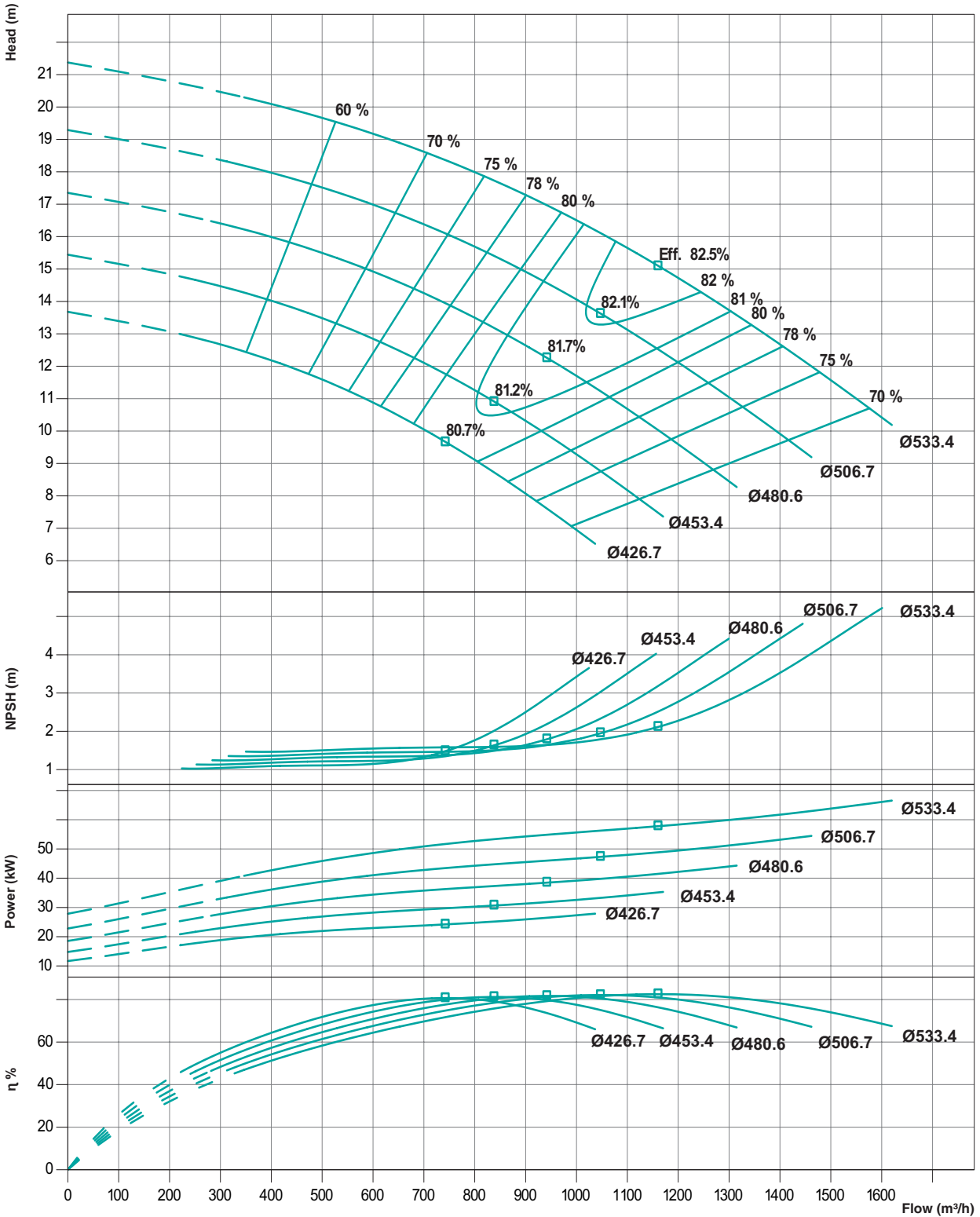

Performance curve tolerances are as per HI : 14.6 / ISO: 9906, Grade 2B

Note : Performance curve are as per specific gravity and viscosity of water.

PERFORMANCE CURVES

Model : **TEP - 14 x 12 x 21**

Speed : **960 rpm**

Suc x Del (in Inches) : **14 x 12**

Max. Impeller Ø : **533.4mm**

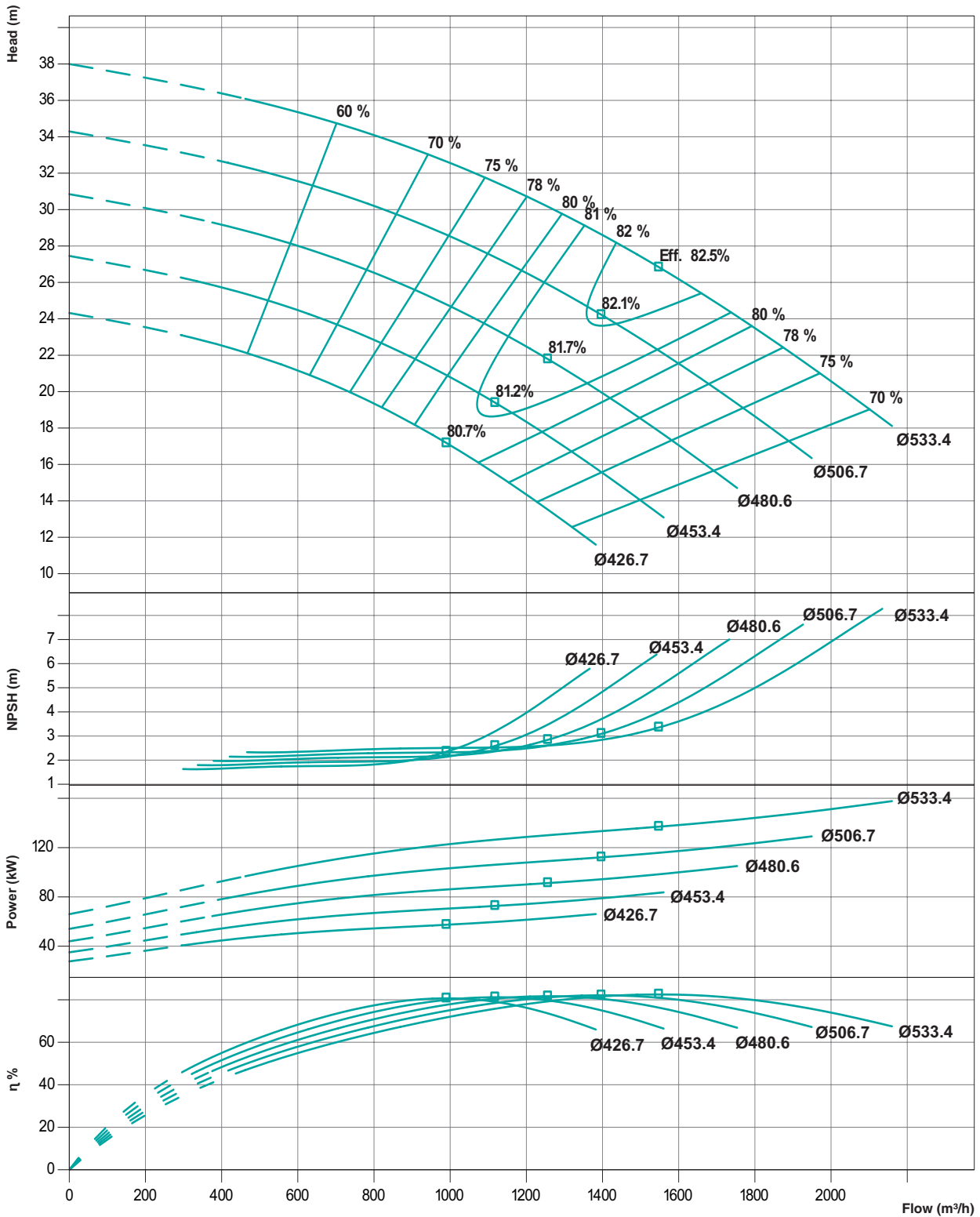

Performance curve tolerances are as per HI : 14.6 / ISO: 9906, Grade 2B

Note : Performance curve are as per specific gravity and viscosity of water.

PERFORMANCE CURVES

Model : **TEP - 16 x 14 x 21**

Speed : **720 rpm**

Suc x Del (in Inches) : **16 x 14**

Max. Impeller Ø : **538mm**

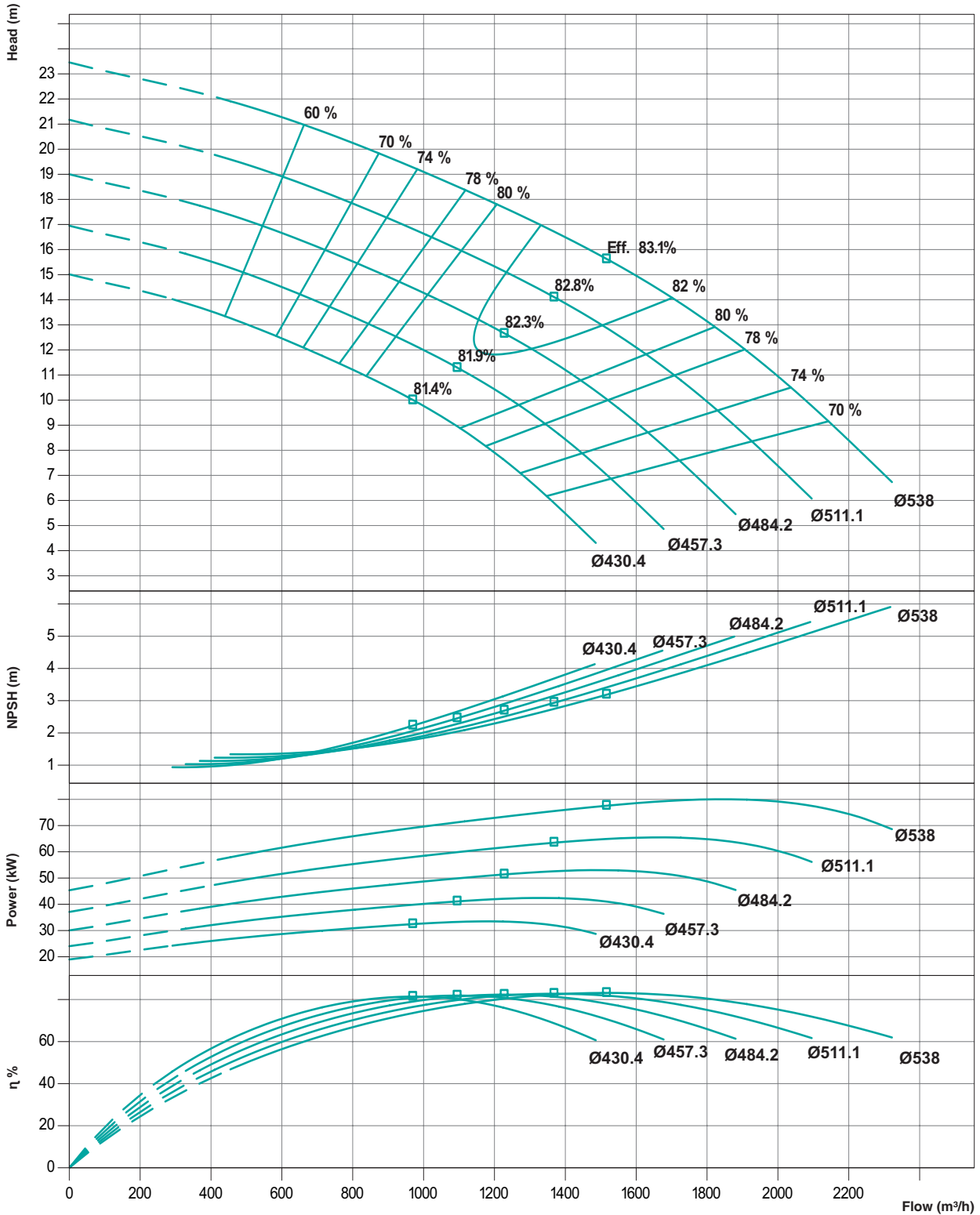

Performance curve tolerances are as per HI : 14.6 / ISO: 9906, Grade 2B

Note : Performance curve are as per specific gravity and viscosity of water.

PERFORMANCE CURVES

Model : **TEP - 16 x 14 x 21**

Speed : **960 rpm**

Suc x Del (in Inches) : **16 x 14**

Max. Impeller Ø : **538mm**

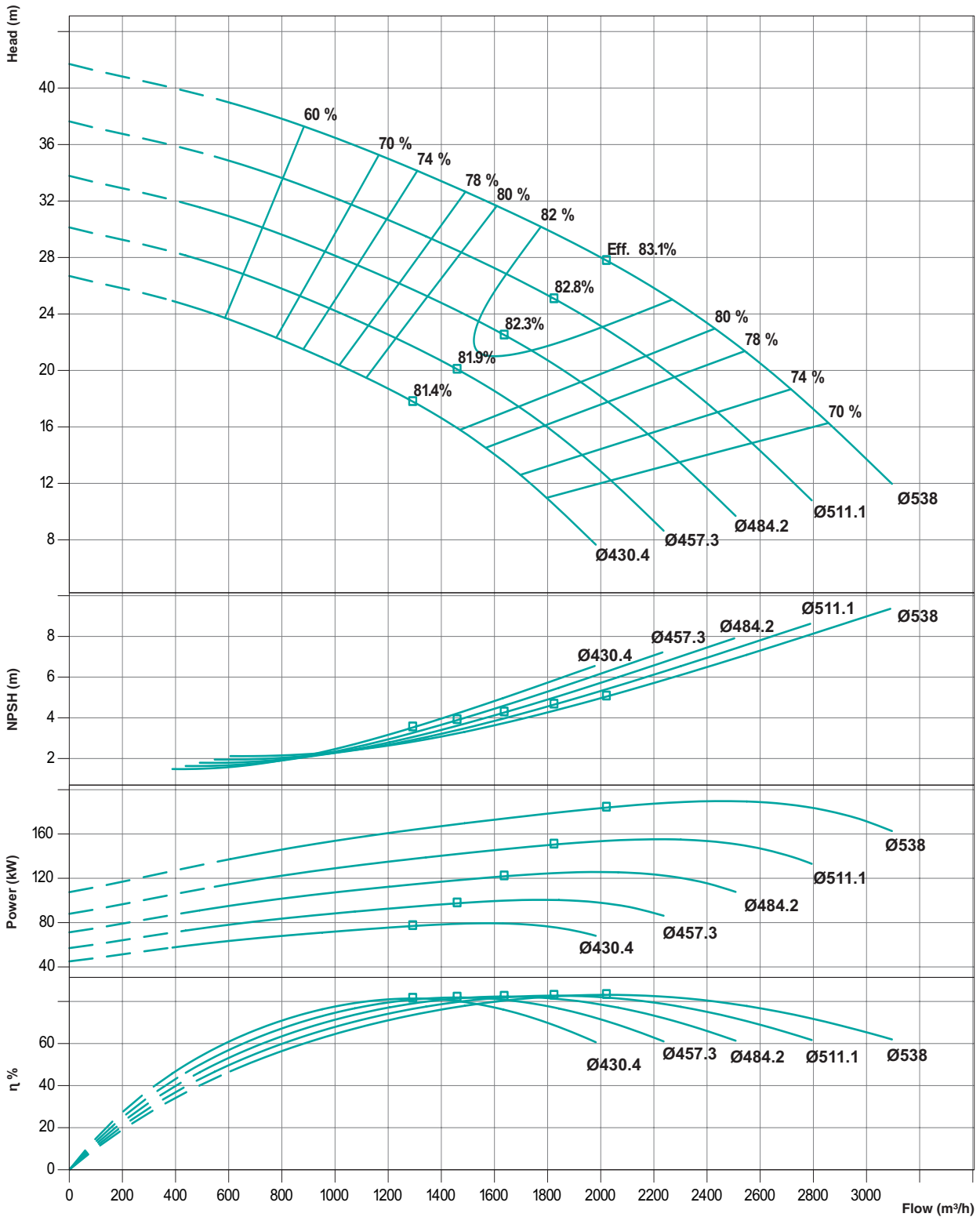

Performance curve tolerances are as per HI : 14.6 / ISO: 9906, Grade 2B

Note : Performance curve are as per specific gravity and viscosity of water.

INTERCHANGEABILITY CHART

Part Name	6 x 3 x 14 (150 x 80 x 350)	6 x 4 x 14 (150 x 100 x 350)	8 x 4 x 17 (200 x 100 x 430)	8 x 5 x 17 (200 x 125 x 430)	8 x 6 x 21 (200 x 150 x 430)	10 x 8 x 21 (250 x 200 x 430)	12 x 10 x 17 (300 x 250 x 430)	8 x 6 x 21 (200 x 150 x 530)	10 x 8 x 21 (250 x 200 x 530)	14 x 12 x 21 (355 x 300 x 530)	16 x 14 x 21 (400 x 355 x 530)
Casing											
Casing Side Flate											
Impeller											
Stuffing Box											
Frame Assembly											

DETAILS OF STANDARD COMPONENTS

SHAFT & BEARING DATA	Frame - I	Frame - II	Frame - III
SHAFT DIAMETER (mm)			
At Coupling	Ø42	Ø60	Ø90
At 'NDE' Bearing	60	85	120
At 'DE' Bearing	50	75	110
Between bearings	63.5	92.1	122.2
Under Sleeve	45	69.82	114.27
STUFFING BOX DIMENSIONS (mm)			
Shaft sleeve Outer Diameter	55	80	135
Stuffing Box Bore diameter	80.5	105.5	173
Stuffing Box Bore diameter	88	93	134.5
SHAFT LENGTH (mm)			
Impeller end of shaft to 'NDE' Bearing	270.2	321.3	406.3
Between bearings	152.4	172.7	335.8
'DE' Bearing to Coupling end	170.1	220.2	282.9
BEARINGS			
'NDE'	21312	21317	22224
'DE'	5310	5315	5222
KEYWAY AT COUPLING (mm)			
Width	12	18	25
Depth	5	7	9
Length	50	56	100
Shaft Thread at Impeller	M36x3 RH	M56x3 RH	M90x6 RH

BARE SHAFT PUMP - MOUNTING DIMENSION

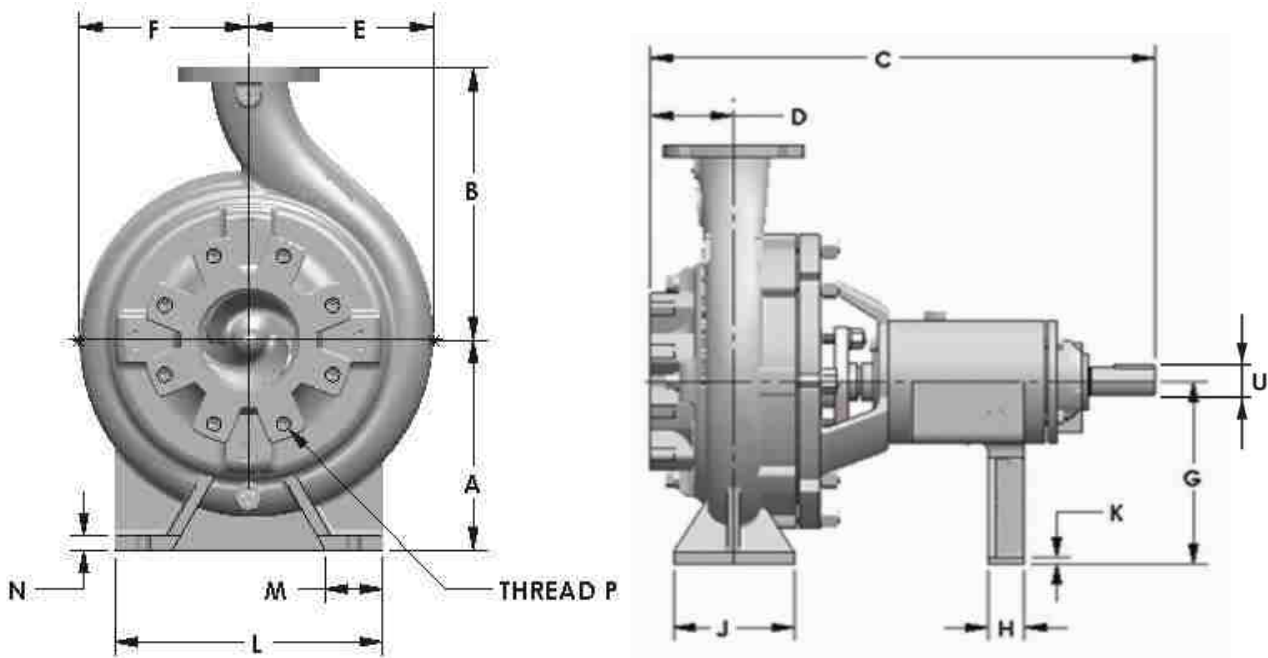

	Frame - I		Frame - II					Frame - III			
	150 x 80 x 350 (6 x 3 x 14)	150 x 100 x 350 (6 x 4 x 14)	200 x 100 x 430 (8 x 4 x 17)	200 x 125 x 430 (8 x 5 x 17)	200 x 150 x 430 (8 x 6 x 17)	250 x 200 x 430 (10 x 8 x 17)	300 x 250 x 430 (12 x 10 x 17)	200 x 150 x 530 (8 x 6 x 21)	250 x 200 x 530 (10 x 8 x 21)	350 x 300 x 530 (14 x 12 x 21)	400 x 350 x 530 (16 x 14 x 21)
A	279	279	368	368	368	432	435	432	432	546	610
B	362	362	559	508	508	559	613	660	711	813	864
C	689.2	685.5	827.7	844.6	859.4	872.1	928.2	1169.5	1175.3	1222.7	1288.6
D	114.3	114.3	128.2	132.1	139.7	139.2	180.8	152.4	154.9	177.8	243.8
E	245.4	248.4	363.6	327.2	359.6	403.1	467.2	418.1	456.7	560.2	631.7
F	225	225	305	280.9	294.7	313.7	334.2	358.8	368.6	422.3	453.2
G	279	279	368	368	368	432	432	432	432	546	610
H	50	50	65	65	65	65	65	70	70	70	70
J	165	165	203	203	203	203	203	254	254	254	254
K	10	10	10	10	10	12	12	14	14	15	15
L	355.6	355.6	445	445	445	445	445	610	685.8	685.8	685.8
M	76.2	76.2	101.6	101.6	101.6	101.6	101.6	152.7	152.4	152.4	152.4
N	19	19	25	25	25	25	25	25	25	25	25
P	M20x2.5	M20x2.5	M20x2.5	M20x2.5	M20x2.5	M24x3	M24x3	M20x2.5	M24x3	M24x3	M24x3
U	42	42	60	60	60	60	60	90	90	90	90

OVERALL RANGE AND PERFORMANCE DETAILS

Pump performance details at 720 rpm

S. No.	Pump Size - Suction x Discharge / Impeller Sizes (inch) (mm)	Suction Nozzle Dia (mm)	Discharge Nozzle Dia (mm)	Pump Weight (kg)	Maximum Power (kW)	Maximum Working Pressure (Bar)	Maximum Flow Rate (m ³ /h)	Maximum Total Head (m)	Maximum Suspended Solid Size (mm)
1	6 x 3 x 14 (150 x 80 x 350)	150	80	275	2.3	1.2	85	12.1	38
2	6 x 4 x 14 (150 x 100 x 350)	150	100	275	4.2	1.2	138	12.1	41
3	8 x 4 x 17 (200 x 100 x 430)	200	100	470	4.2	1.6	210	16.8	38
4	8 x 6 x 17 (200 x 150 x 430)	200	150	500	13.7	1.6	440	16.5	76
5	8 x 6 x 21 (200 x 150 x 430)	200	150	850	31.3	2.5	530	25.1	76
6	10 x 8 x 17 (250 x 200 x 430)	250	200	550	17.6	1.5	520	15.7	63
7	10 x 8 x 21 (250 x 200 x 430)	250	200	900	36.2	2.4	750	24.6	76
8	12 x 10 x 17 (300 x 250 x 430)	300	250	650	22.9	1.3	925	13.3	38
9	14 x 12 x 21 (355 x 300 x 530)	350	300	1050	66.6	2.1	1625	21.4	95
10	16 x 14 x 21 (400 x 355 x 530)	400	350	1350	80.0	2.3	2300	23.5	50

OVERALL RANGE AND PERFORMANCE DETAILS

Pump performance details at 960 rpm

S. No.	Pump Size - Suction x Discharge / Impeller Sizes (inch) (mm)	Suction Nozzle Dia (mm)	Discharge Nozzle Dia (mm)	Pump Weight (kg)	Maximum Power (kW)	Maximum Working Pressure (Bar)	Maximum Flow Rate (m ³ /h)	Maximum Total Head (m)	Maximum Suspended Solid Size (mm)
1	6 x 3 x 14 (150 x 80 x 350)	150	80	275	5.5	2.1	113	21.5	38
2	6 x 4 x 14 (150 x 100 x 350)	150	100	275	10.0	2.1	185	21.6	41
3	8 x 4 x 17 (200 x 100 x 430)	200	100	470	21.0	2.9	280	29.8	38
4	8 x 6 x 17 (200 x 150 x 430)	200	150	500	32.5	2.9	580	29.5	76
5	10 x 8 x 17 (250 x 200 x 430)	250	200	550	41.7	2.7	700	27.9	63
6	8 x 6 x 21 (200 x 150 x 430)	200	150	850	74.0	4.4	725	44.0	76
7	10 x 8 x 21 (250 x 200 x 430)	250	200	900	85.7	4.3	1000	43.8	76
8	12 x 10 x 17 (300 x 250 x 430)	300	250	650	54.3	2.3	1250	23.6	38
9	14 x 12 x 21 (355 x 300 x 530)	350	300	1050	157.7	3.8	2150	38.0	95
10	16 x 14 x 21 (400 x 355 x 530)	400	350	1350	189.7	4.0	3100	41.0	50

OVERALL RANGE AND PERFORMANCE DETAILS

Pump performance details at 1450 rpm

S. No.	Pump Size - Suction x Discharge / Impeller Sizes (inch) (mm)	Suction Nozzle Dia (mm)	Discharge Nozzle Dia (mm)	Pump Weight (kg)	Maximum Power (kW)	Maximum Working Pressure (Bar)	Maximum Flow Rate (m ³ /h)	Maximum Total Head (m)	Maximum Suspended Solid Size (mm)
1	3 x 2.5 x 10.5 (80 x 65 x 260)	80	65	77	3.2	1.8	75	18	22
2	3 x 2.5 x 11 (80 x 65 x 280)	80	65	77	4.5	2.4	96	24	23
3	4 x 3 x 10.5 (100 x 80 x 260)	100	80	86.5	3.7	1.5	109	15.5	30
4	4 x 3 x 11 (100 x 80 x 280)	100	80	86.5	5.6	2.0	100	20	32
5	6 x 3 x 14 (150 x 80 x 350)	150	80	275	19.1	4.8	172	49	38
6	6 x 4 x 14 (150 x 100 x 350)	150	100	275	35.0	4.8	280	49.3	41
7	8 x 4 x 17 (200 x 100 x 430)	200	100	470	73.0	6.8	430	68	38
8	8 x 5 x 17 (200 x 125 x 430)	200	125	480	93.0	6.7	550	68.3	63
9	8 x 6 x 17 (200 x 150 x 430)	200	150	500	112.0	6.7	880	67	76
10	8 x 6 x 21 (200 x 150 x 430)	200	150	850	255.0	10.0	1100	101	76
11	10 x 8 x 21 (250 x 200 x 430)	250	200	900	295.0	9.8	1500	100	76
12	10 x 8 x 17 (250 x 200 x 430)	250	200	550	143.0	6.3	1300	63.7	63
13	12 x 10 x 17 (300 x 250 x 430)	300	250	650	187.0	5.3	1850	50	38



T H E P O W E R B E H I N D T H E F O R C E

Naargo Industries Private Limited, one of the leading manufacturers of latest state of art, large range of pumps and motors, is managed by veterans who are in the pump industry for almost half a century. The products are employed in various applications like irrigation, domestic, civil construction, de-watering etc; The Company has a strong distribution network in India for sales & service and a strong global presence.

Quality is the key factor in Naargo's products. The expansive infrastructure and environment accredited with ISO 9001 quality certification, latest engineering softwares, high-tech machinery, futuristic pumping technology and high caliber workforce facilitate the production of flawless and efficient products on par with international standards under the brand name of "Tormac". The well equipped R & D wing stays alive to the changing global trends and comes out with viable solutions for innovative product development and upgradation.

The Products currently available include Stainless Steel Submersible Pumps (SS 304, SS 316 & SS 904L), Submersible Motors (CI, SS 304, SS 316 & SS 904L - HT on optional), Starters & Control Panels, Centrifugal Monoblock Pumps, End Suction Pumps, Close Coupled Pumps, Horizontal Split Case Pumps, Horizontal & Vertical Multistage Pumps, Inline Booster Systems, Sewage, Drainage & Dewatering Pumps, Induction Motors, Submersible Cables, Riser Pipes and Column Pipes.

The power, performance and endurance of the products backed by the uncompromising teamwork and value systems will certainly propel the company's growth towards new horizons in the pump industry.

IC-TEP-B/26-E3

Naargo Industries Private Limited,

REG. OFFICE : No. 8/116, Ground Floor, Athipalayam Road, Chinnavedampatti,
Coimbatore North - 641049, Tamil Nadu, India. Tel : +91 978 6522622,
E-mail : tormac@tormacpumps.com, Web : www.tormacpumps.com

Tormac
P U M P S