



## THE HARD WORKING PUMP

The result of superior technology and expertise that has stood the test of time.



VERTICAL TURBINE PUMPS - 60Hz

**TVT - SERIES**



# C O N T E N T S

## VERTICAL TURBINE PUMPS

<b>TVT SERIES - 60Hz</b>	<b>Page No.</b>
Description	4
Model Designation, Operating Data, Key Features & Applications	5
Materials of Construction	6
Performance Curves	7 - 22
General Dimensions and Mounting Details - Bowl Assembly	23
Cross Section view with Solid Shaft Motor for External Clear Water Lubrication	24
Cross Section view with Solid Shaft Motor for Self Water Lubrication	25
Cross Section view with Solid Shaft Motor for Oil Lubrication	26
Cross Section view with Vertical Hollow Shaft Motor for External Clear Water Lubrication	27
Cross Section view with Vertical Hollow Shaft Motor for Self Water Lubrication	28
Cross Section view with Vertical Hollow Shaft Motor for Oil Lubrication	29
Line Shaft Coupling Types	30
Thrust Bearing with Ratchet Arrangement	31
Lubrication Arrangement	32
Discharge Head with Above Ground Level Arrangement	33
General Arrangement Drawing (GAD) with Solid Shaft Motor	34
General Dimensions & Mounting Details for Solid Shaft Motor	35
General Arrangement Drawing (GAD) with Vertical Hollow Shaft Motor	36
General Dimensions & Mounting Details for Vertical Hollow Shaft Motor	37
Engine Driven Pump with Right Angle Gear Box	38

## GENERAL DATA

### VERTICAL TURBINE PUMPS > TVT - SERIES

Vertical Turbine (TVT) pumps are high-efficiency pumps designed for reliable operation in applications requiring the movement of large volumes of water. Available in both single-stage and multistage configurations, these pumps feature submerged impellers, enabling them to start without the need for priming. Depending on the flow requirements, they are equipped with either mixed flow or axial flow impellers to deliver high flow rates efficiently.

The pump assembly includes a transmission shaft housed within column pipes, supported by line shaft bearings. These bearings can be lubricated either through self-water or an external cooling system, depending on the installation environment and operating conditions.

TVT pumps can be installed in both wet pit and dry pit configurations, offering flexibility to suit a wide range of site conditions. To enhance safety and operational reliability, a ratchet arrangement is provided on the coupling to prevent reverse rotation during shutdown or power failure. With the robust design and adaptability, Vertical Turbine pumps are a dependable solution for demanding water transfer applications.

#### **Bowl**

A diffuser with vanes cast integrally.

#### **Impeller**

Impellers are of mixed flow or axial flow.

#### **Suction bell**

Designed for smooth entry of water with minimum losses.

#### **Strainer**

Stainless steel basket type strainers are provided in standard installation in the suction bell to prevent large solids from entering the pump.

#### **Shaft**

The shaft materials provided are of high tensile strength.

#### **Column pipe**

Column pipes are designed in such a way to transfer the water smoothly from bowl assembly to discharge head and the pipes are made either in casted or fabricated.

#### **Bearings**

##### **Line Shaft Bearing**

Cutlass bearings are of higher bond strength between rubber and shell material. Also provided in composite material like thordon and ferroform. Lubrication by self/external clear water.  
Oil lubrication will be provided with bronze bearing.

#### **Discharge Head**

Either casted or fabricated discharge head is provided to direct flow from column pipe to discharge head located above the ground level.

#### **Thrust Bearing**

Antifriction type bearings are provided for taking hydraulic axial thrust and weight of rotating unit. Lubrication with oil or grease. Non-reverse ratchet assembly provided to prevent reverse rotation of pump due to back flow of the water in case of its tripping.

#### **Motor stool**

Rigid and rugged construction to ensure vibration-free operation of pumpset.

#### **Coupling**

Flexible pin bush type couplings are generally provided to couple pump and motor. For line shaft coupling either threaded barrel type or muff couplings are provided.

#### **Drive**

Electric motor with solid shaft is a standard arrangement on request we can provide vertical hollow shaft drive also. Engine driven pumps are provided with right angle gear drive.

#### **Direction of rotation**

Clockwise when viewed from driving end.

Note: The company reserves the right to modify the technical specification and the illustrations without notice.

## Model Designation

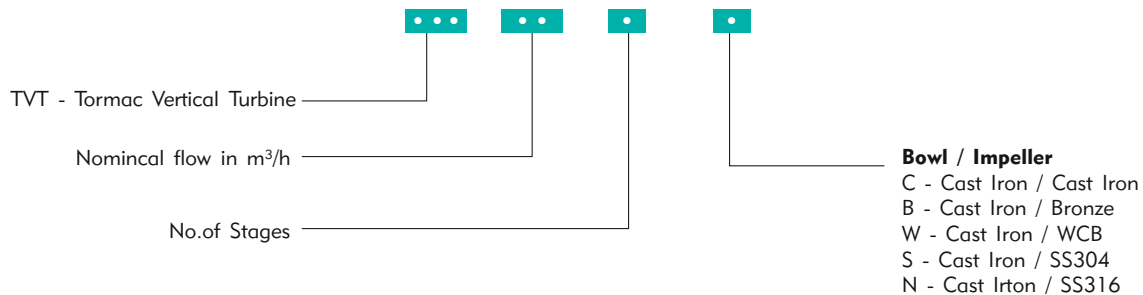

## Operating Data

Head Range	1100 ft
Flow Range	57000 usgpm
Speed	710, 890 & 1750 rpm
Impeller Type	Closed Impeller
Outlet Size	6" - 36"
Power Range	200 HP
Maximum Liquid Temperature	-10°C to 90°C
Shaft Seal	Standard : Gland Packing
	Optional : Mechanical Seal
Bearing Lubrication	Self & External Lubrication
Flange Standard	DIN 16
Maximum working Pressure	25bar

### Key Features

- Wide hydraulic ranges,
- Suction bell bearing provided for better stability
- Below and above ground level discharge head
- Radial bearing support between 1.5m shaft length
- Different material options
- Optional surface coating for efficiency improvement

### Applications

- Raw water intake and supply
- Main cooling water and makeup water supply in power plants
- Cooling tower
- Water Treatment plants
- Municipal water supply
- Dockyard and off shores platforms
- Flood Control
- Fire Fighting.
- Irrigation
- Sugar, Refinery and steel plants

## Material of Construction

Parts Name	Material (Code)	SAE/AISI	DIN	EUROPEAN
Bowl	Cast Iron (C)	ASTM A48 Class 40B	(0.6025) GG25	EN-GJL-250
Suction Bell	Cast Iron (C)	ASTM A48 Class 40B	(0.6025) GG25	EN-GJL-250
Impeller	Cast Iron (C)	ASTM A48 Class 40B	(0.6025) GG25	EN-GJL-250
	Bronze (B)	ASTMB 584 - C90500	DIN 1705 Rg 5	CuSn5Zn5Pb5C
	WCB (W)	ASTM A216 WCB	1.0619	GP240GH
	CF8 (S)	ASTM A743 / A351 CF8	1.4301	X5CrNi18-10
	CF8M (N)	ASTM A743 / A351 CF8M	1.4408	GX5CrNiMo19-11-2
Wear Ring	Cast Iron (C)	ASTM A48 Class 40B	(0.6025) GG25	EN-GJL-250
	Bronze (B)	ASTMB 584 - C90500	DIN 1705 Rg 5	CuSn5Zn5Pb5C
	CF8 (S)	ASTM A743 / A351 CF8	1.4301	X5CrNi18-10
	CF8M (N)	ASTM A743 / A351 CF8M	1.4408	GX5CrNiMo19-11-2
Shaft	SS410 (K)	ASTM A276 AISI 410	1.4006	X12Cr13
	SS304 (S)	ASTM A276 AISI 304	1.4301	X5CrNi18-10
	SS316 (N)	ASTM A276 AISI 316	1.4401	X5CrNiMo18-10
Sleeve	SS410 (K)	ASTM A276 AISI 410	1.4006	X12Cr13
	SS304 (S)	ASTM A276 AISI 304	1.4301	X5CrNi18-10
	SS316 (N)	ASTM A276 AISI 316	1.4401	X5CrNiMo18-10
Pipe Column	Mild Steel (MS)	ASTM-A283 GR.D	1.0044 (RSt 42-2, St 44-2)	Fe430B
Enclosing Pipe	Mild Steel (MS)	ASTM-A283 GR.D	1.0044 (RSt 42-2, St 44-2)	Fe430B
Cone Pipe	Cast Iron (C)	ASTM A48 Class 40B	(0.6025) GG25	EN-GJL-250
	Mild Steel (MS)	ASTM-A283 GR.D	1.0044 (RSt 42-2, St 44-2)	Fe430B
Discharge Head	Cast Iron (C)	ASTM A48 Class 40B	(0.6025) GG25	EN-GJL-250
	Mild Steel (MS)	ASTM-A283 GR.D	1.0044 (RSt 42-2, St 44-2)	Fe430B
Motor Stool	Cast Iron (C)	ASTM A48 Class 40B	(0.6025) GG25	EN-GJL-250
	Mild Steel (MS)	ASTM-A283 GR.D	1.0044 (RSt 42-2, St 44-2)	Fe430B
Sole Plate	Mild Steel (MS)	ASTM-A283 GR.D	1.0044 (RSt 42-2, St 44-2)	Fe430B
Strainer	SS304 (S)	ASTM A276 AISI 304	1.4301	X5CrNi18-10
Bearing Holder	Cast Iron (C)	ASTM A48 Class 40B	(0.6025) GG25	EN-GJL-250
Bowl and Line Shaft Bearing	Bronze / Ferroform / Thordon / Rubber	ASTM B505 C93800 / Ferroform / Thordon / Rubber	DIN 1716-1981 / Ferroform / Thordon / Rubber	G-CuPb15Sn Ferroform / Thordon / Rubber
Bearing Housing	Cast Iron (C)	ASTM A48 Class 40B	(0.6025) GG25	EN-GJL-250
Bearing Housing Cover	Cast Iron (C)	ASTM A48 Class 40B	(0.6025) GG25	EN-GJL-250
Key	SS410 (K)	ASTM A276 AISI 410	1.4006	X12Cr13
	SS304 (S)	ASTM A276 AISI 304	1.4301	X5CrNi18-10
	SS316 (N)	ASTM A276 AISI 316	1.4401	X5CrNiMo18-10
Pump & Motor Coupling	Cast Iron (C)	ASTM A48 Class 40B	(0.6025) GG25	EN-GJL-250
Gland	Cast Iron (C)	ASTM A48 Class 40B	(0.6025) GG25	EN-GJL-250

Impeller Optional Materials : Duplex, Super Duplex and other materials are available on request.

Note: The company reserves the right to modify the technical specification and the illustrations without notice.

### Performance Curves

PUMP MODEL : **TVT-115**

Speed : **1750 rpm**

Delivery size in mm : **150mm**  
Max Impeller OD : **189mm**

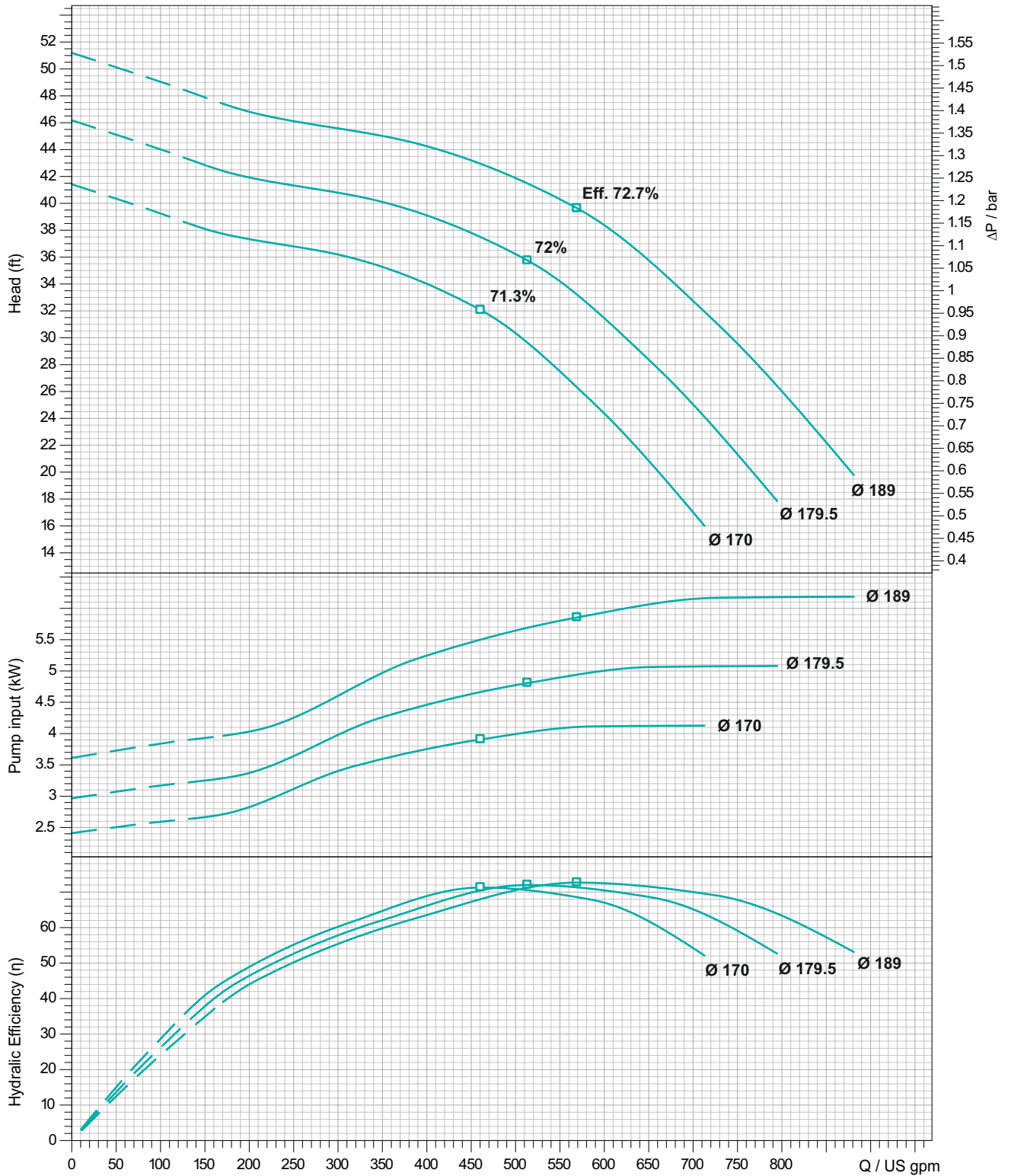

This Pump can be supplied upto max. 14 Stages.  
Max. Head can be supplied upto 14 Stages x 47ft = 658 ft.

Note: The company reserves the right to modify the technical specification and the illustrations without notice.

## Performance Curves

PUMP MODEL : **TVT-170**

Speed : **1750 rpm**

Delivery size in mm : **150mm**  
Max Impeller OD : **238mm**

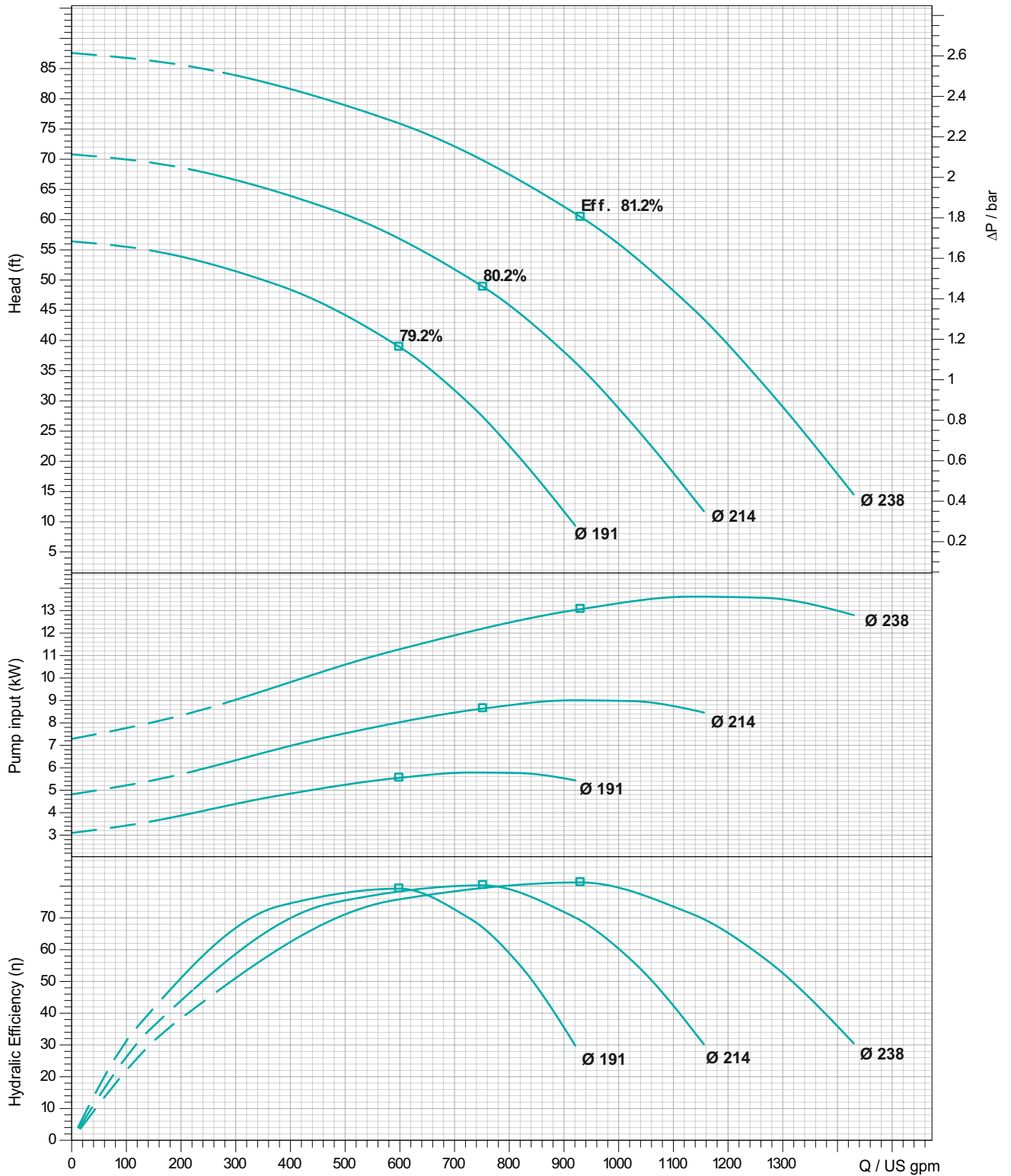

This Pump can be supplied upto max.12 Stages.  
Max. Head can be supplied upto 12 Stages x 83ft = 996 ft.

Note: The company reserves the right to modify the technical specification and the illustrations without notice.

### Performance Curves

PUMP MODEL : **TVT-270**

Speed : **1750 rpm**

Delivery size in mm : **200mm**  
Max Impeller OD : **275mm**

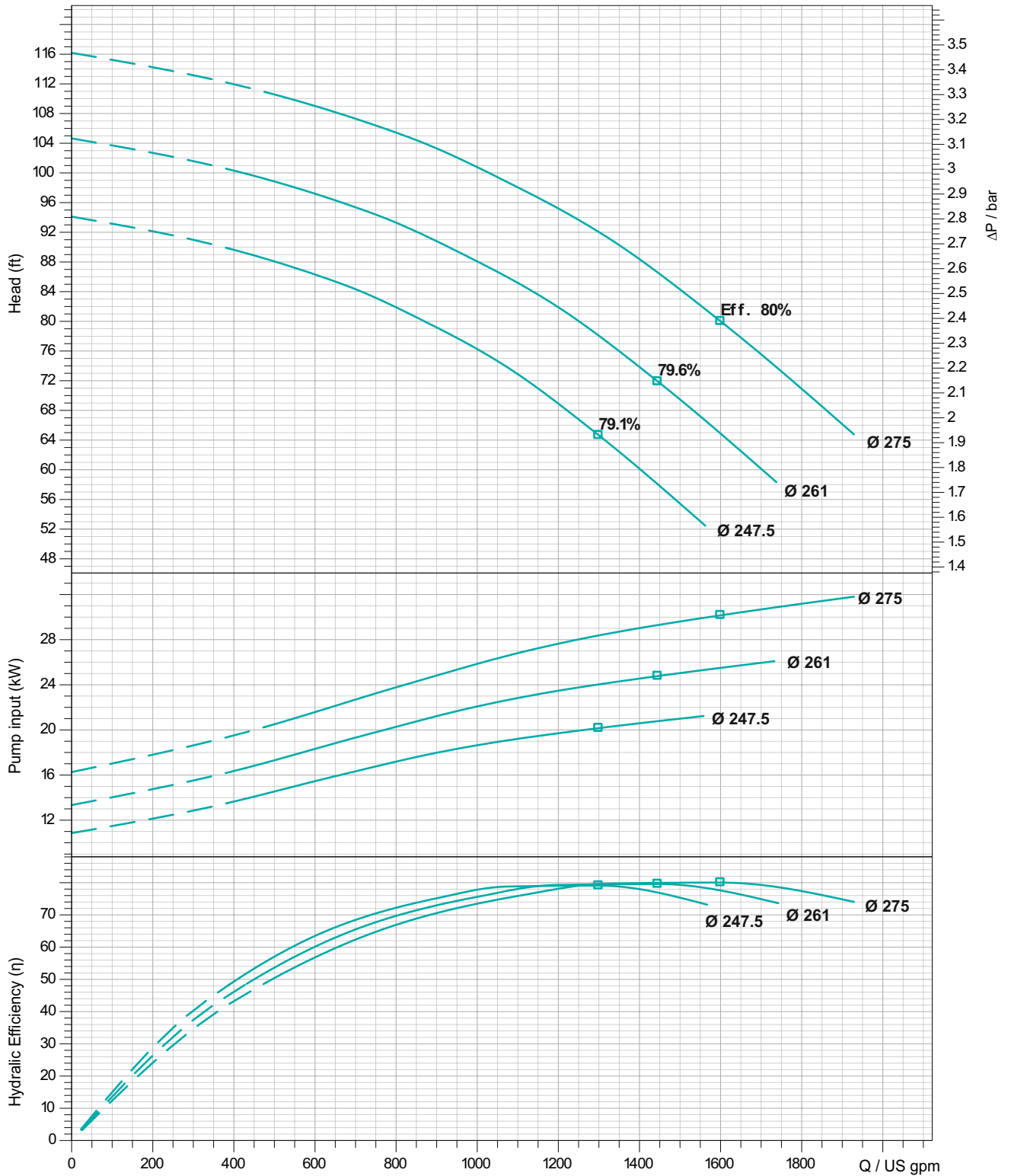

This Pump can be supplied upto max.10 Stages.  
Max. Head can be supplied upto 10 Stages x 110 ft = 1100 ft.

Note: The company reserves the right to modify the technical specification and the illustrations without notice.

## Performance Curves

PUMP MODEL : **TVT-400**

Speed : **1750 rpm**

Delivery size in mm : **200mm**  
Max Impeller OD : **281mm**

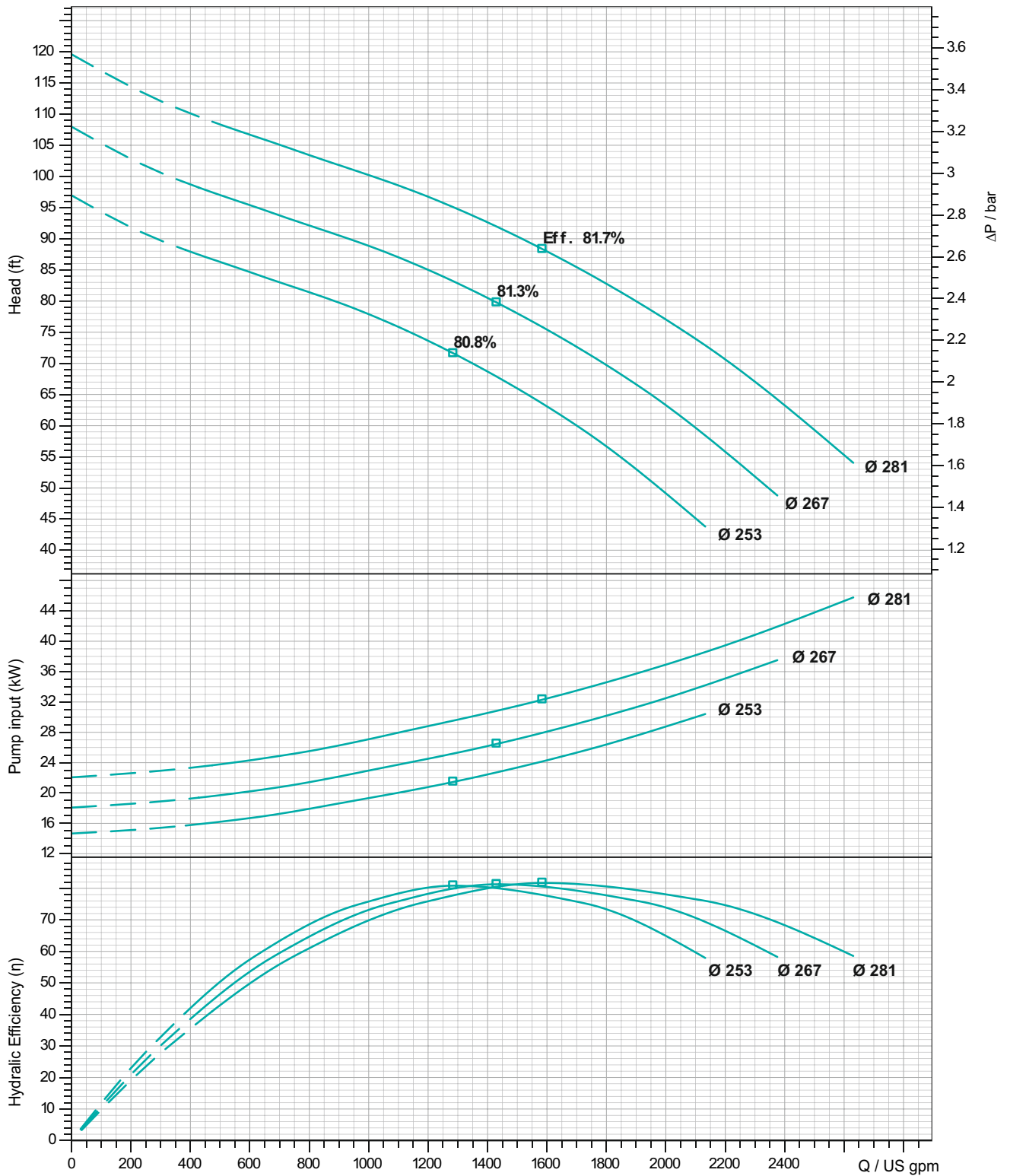

This Pump can be supplied upto max.10 Stages.  
Max. Head can be supplied upto 10 Stages x 108 ft = 1080 ft.

Note: The company reserves the right to modify the technical specification and the illustrations without notice.

### Performance Curves

PUMP MODEL : **TVT-500**

Speed : **1750 rpm**

Delivery size in mm : **250mm**  
Max Impeller OD : **304mm**

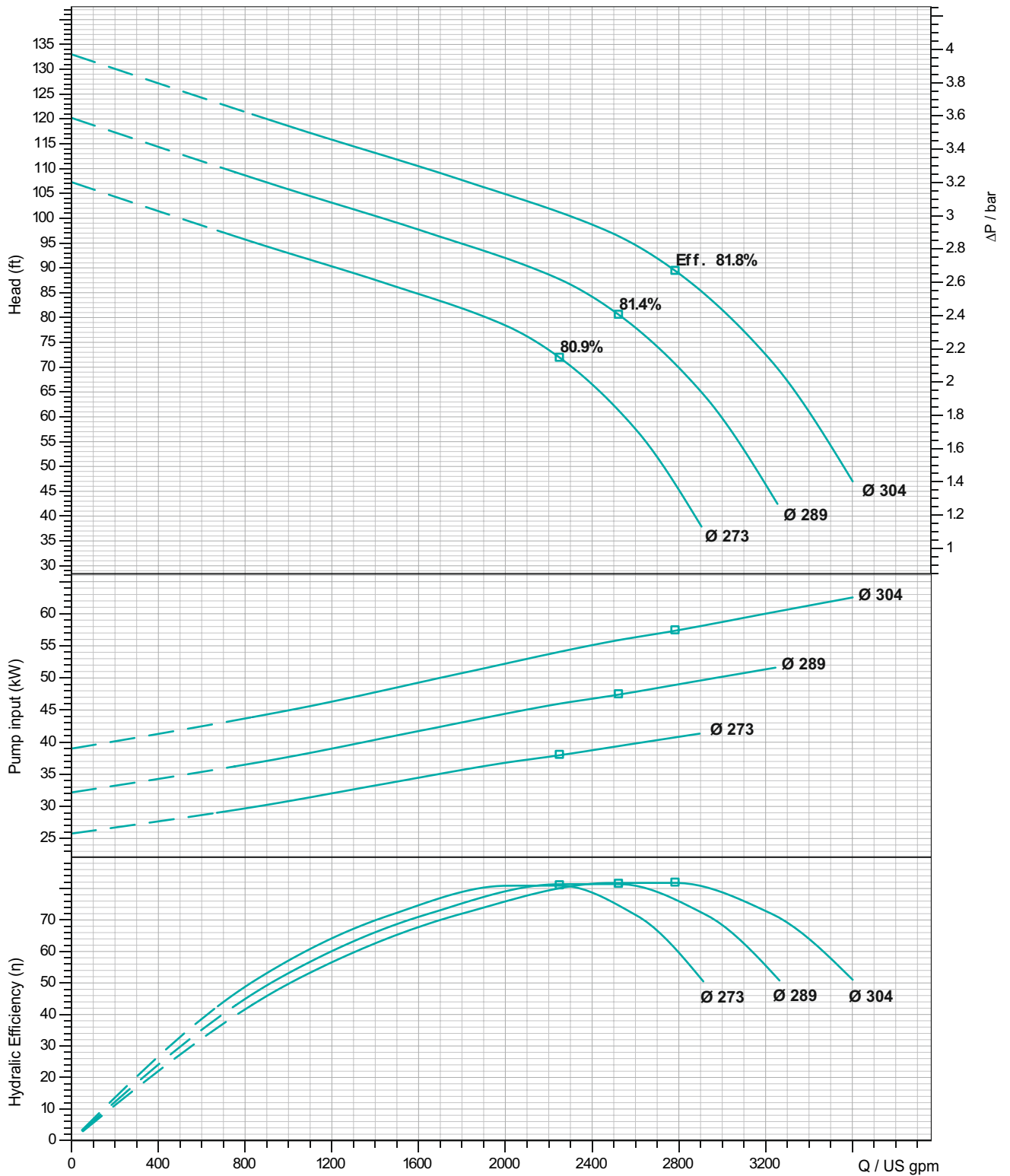

This Pump can be supplied upto max.7 Stages.  
Max. Head can be supplied upto 7 Stages x 120 ft = 840 ft.

Note: The company reserves the right to modify the technical specification and the illustrations without notice.

## Performance Curves

PUMP MODEL : **TVT-700**

Speed : **1750 rpm**

Delivery size in mm : **250mm**  
Max Impeller OD : **338mm**

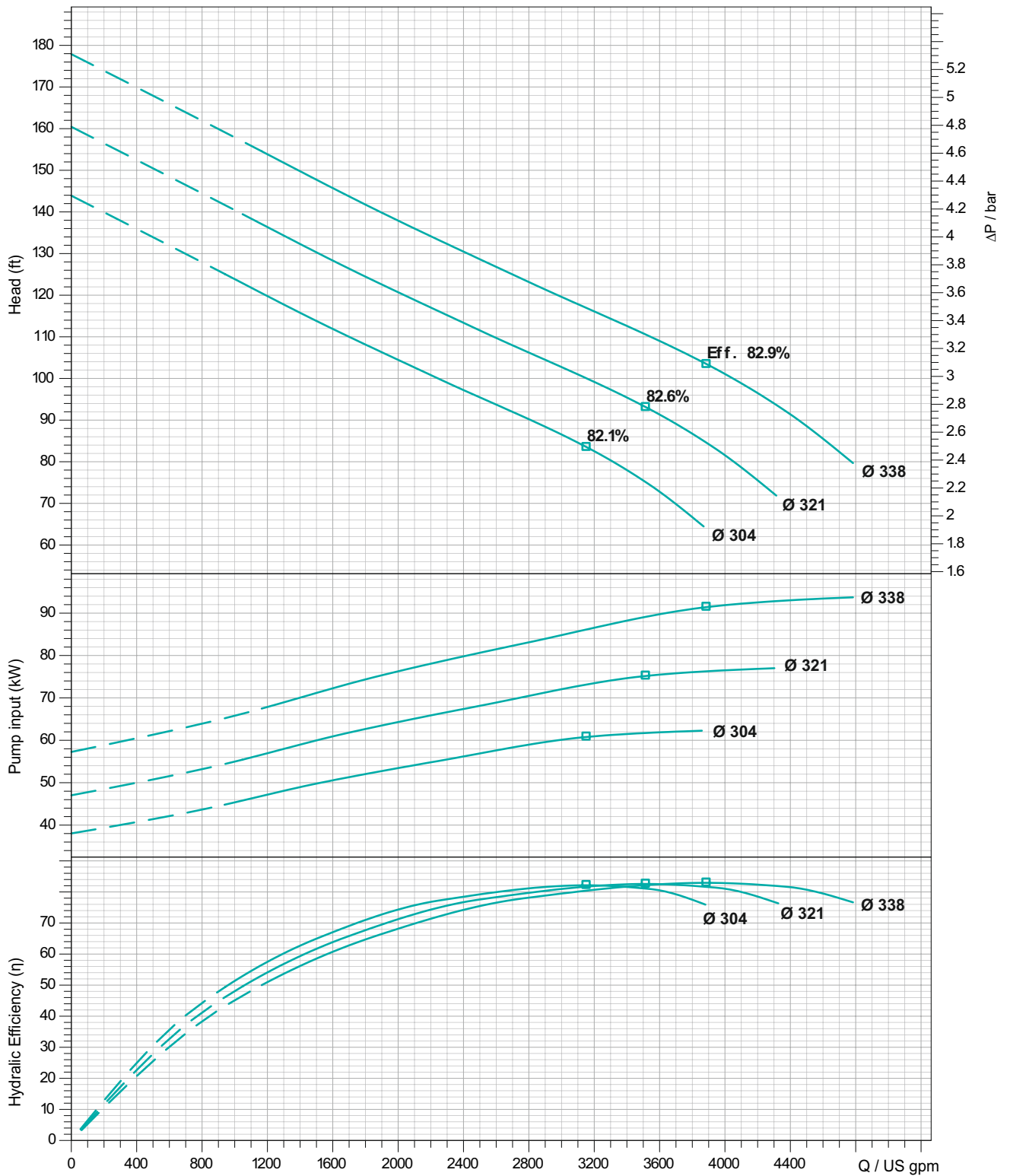

This Pump can be supplied upto max. 5 Stages.  
Max. Head can be supplied upto 5 Stages x 154 ft = 770 ft.

Note: The company reserves the right to modify the technical specification and the illustrations without notice.

### Performance Curves

PUMP MODEL : **TVT-1000**

Speed : **1750 rpm**

Delivery size in mm : **300mm**  
Max Impeller OD : **384mm**

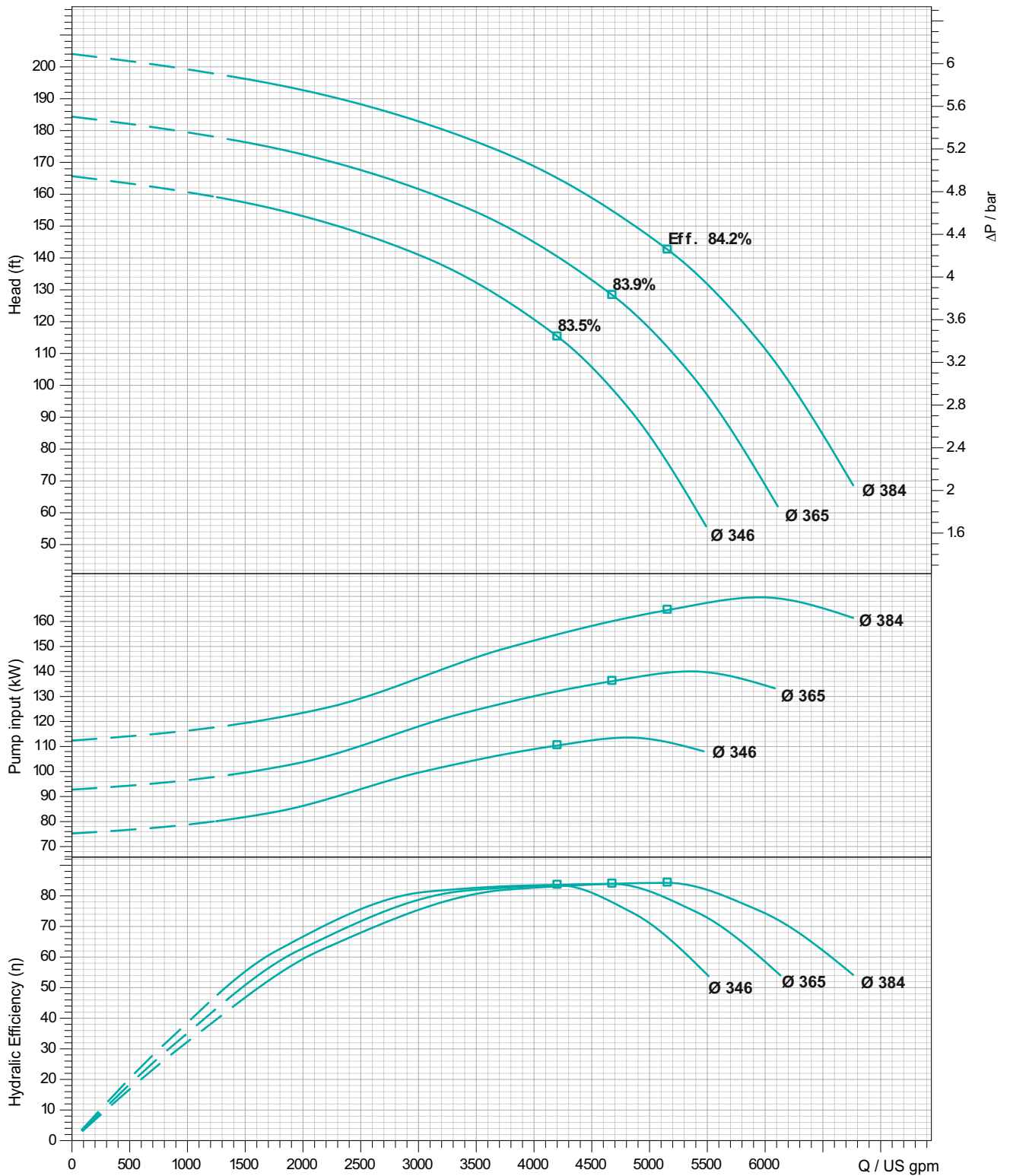

This Pump can be supplied upto max. 4 Stages.  
Max. Head can be supplied upto 4 Stages x 195 ft = 780 ft.

Note: The company reserves the right to modify the technical specification and the illustrations without notice.

## Performance Curves

PUMP MODEL : **TVT-1600**

Speed : **1750 rpm**

Delivery size in mm : **350mm**  
Max Impeller OD : **442mm**

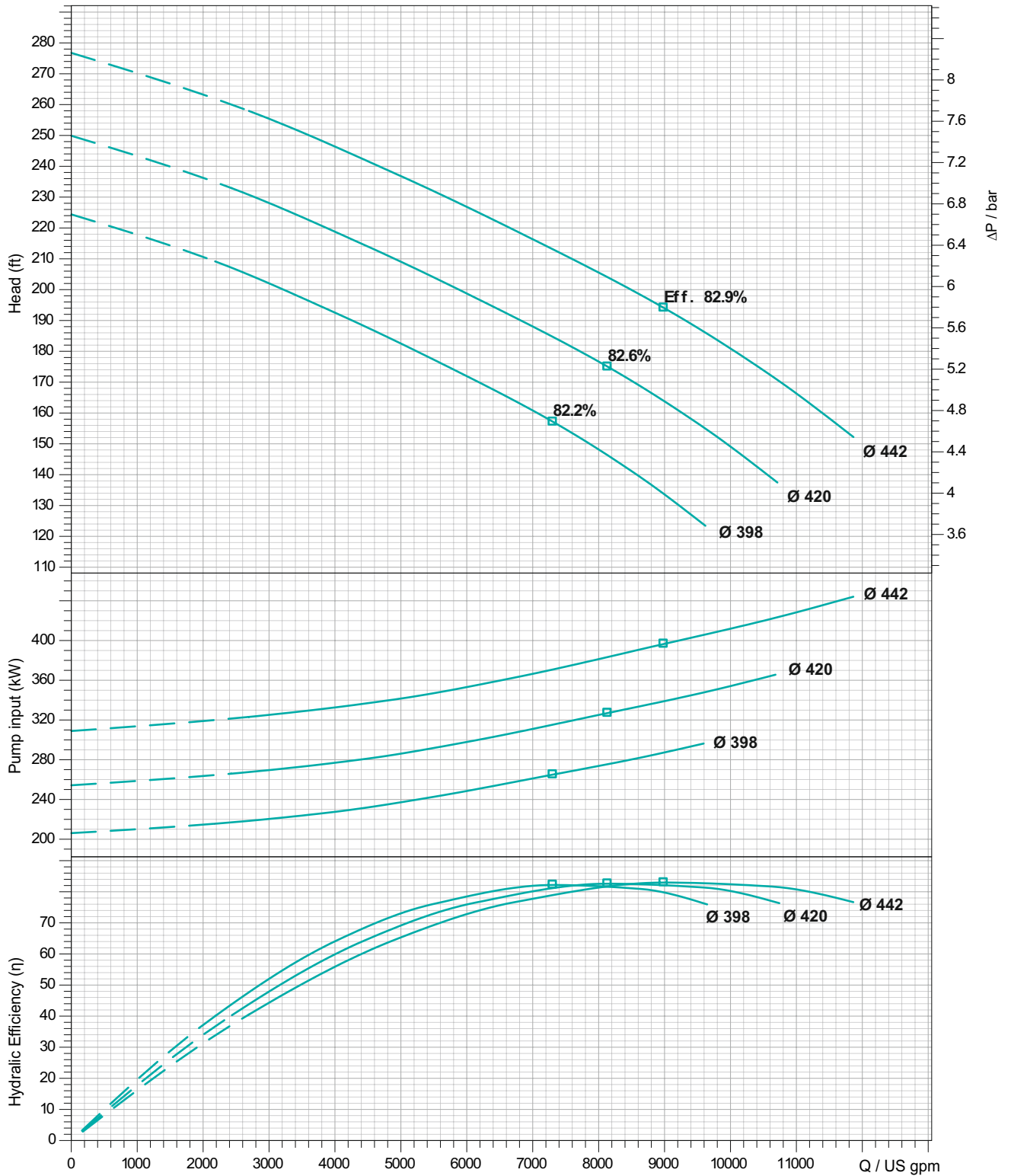

This Pump can be supplied upto max. 2 Stages.  
Max. Head can be supplied upto 2 Stages x 256 ft = 512 ft.

Note: The company reserves the right to modify the technical specification and the illustrations without notice.

### Performance Curves

PUMP MODEL : **TVT-2300**

Speed : **1750 rpm**

Delivery size in mm : **500mm**  
Max Impeller OD : **470mm**

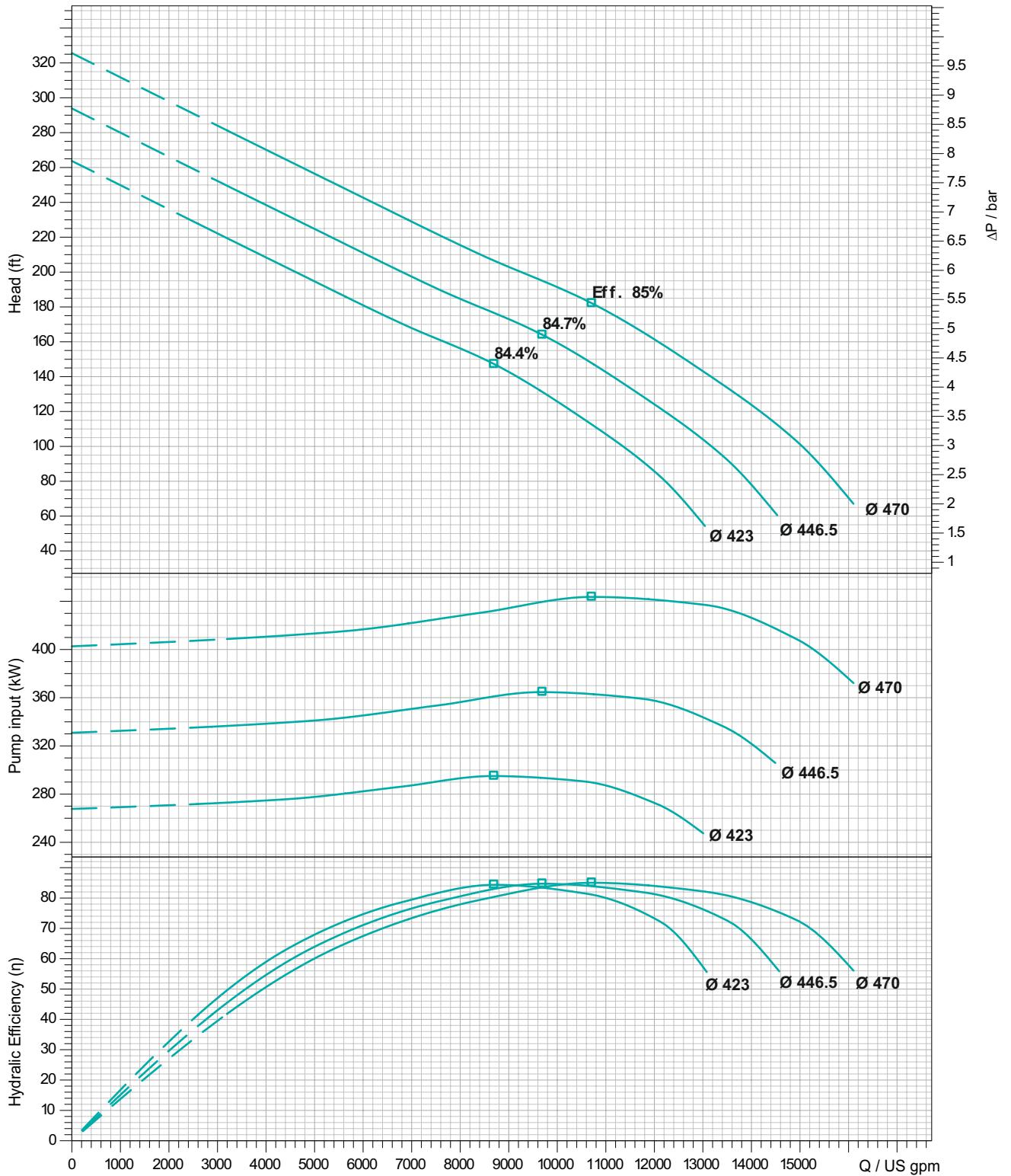

This Pump can be supplied upto max. 2 Stages.  
Max. Head can be supplied upto 2 Stages x 280 ft = 560 ft.

Note: The company reserves the right to modify the technical specification and the illustrations without notice.

## Performance Curves

PUMP MODEL : **TVT-3300**

Speed : **1750 rpm**

Delivery size in mm : **500mm**  
Max Impeller OD : **526mm**

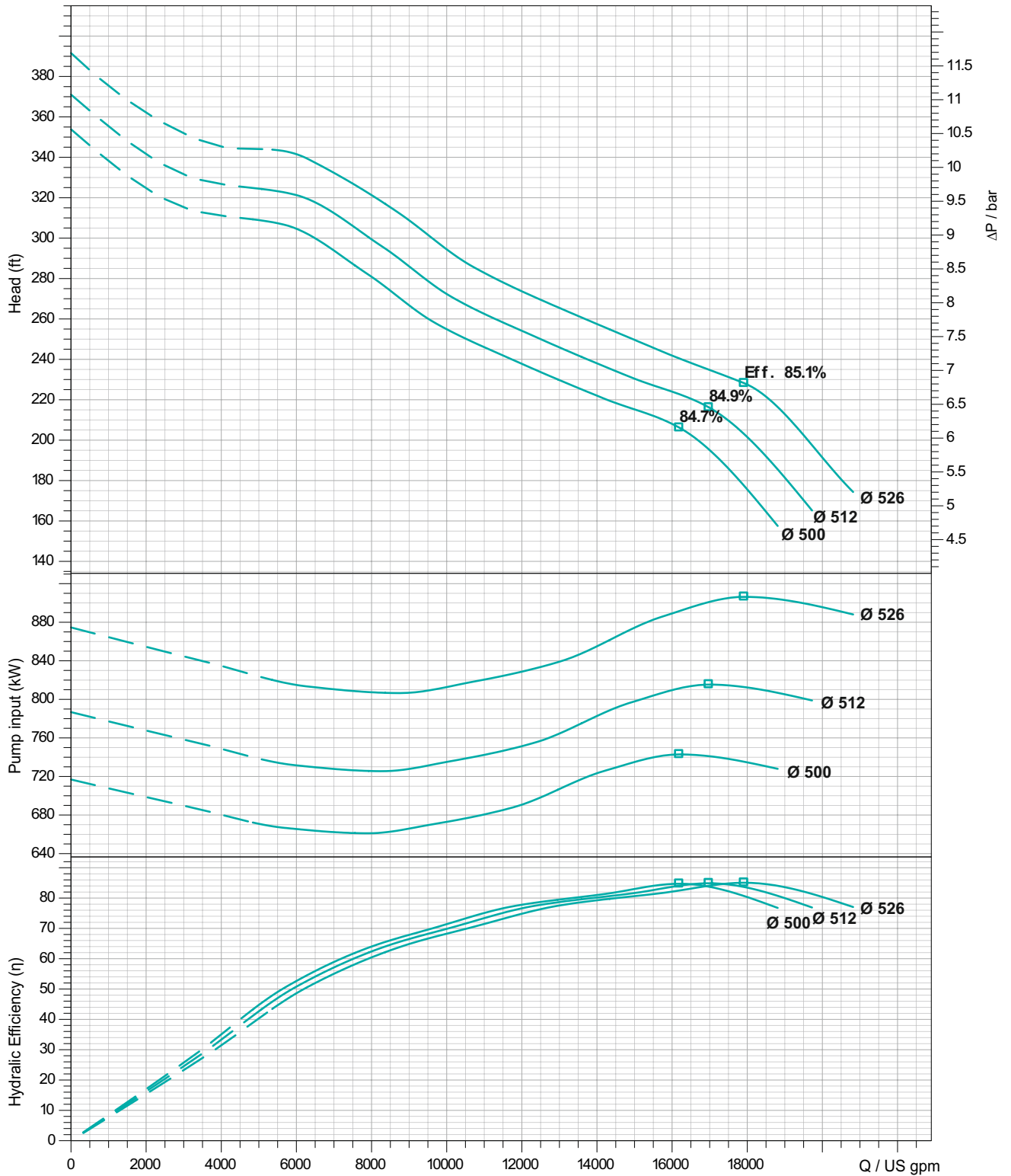

This Pump can be supplied upto max. 2 Stages.  
Max. Head can be supplied upto 2 Stages x 342 ft = 684 ft.

Note: The company reserves the right to modify the technical specification and the illustrations without notice.

### Performance Curves

PUMP MODEL : **TVT-4500**

Speed : **1150 rpm**

Delivery size in mm : **700mm**  
Max Impeller OD : **664mm**

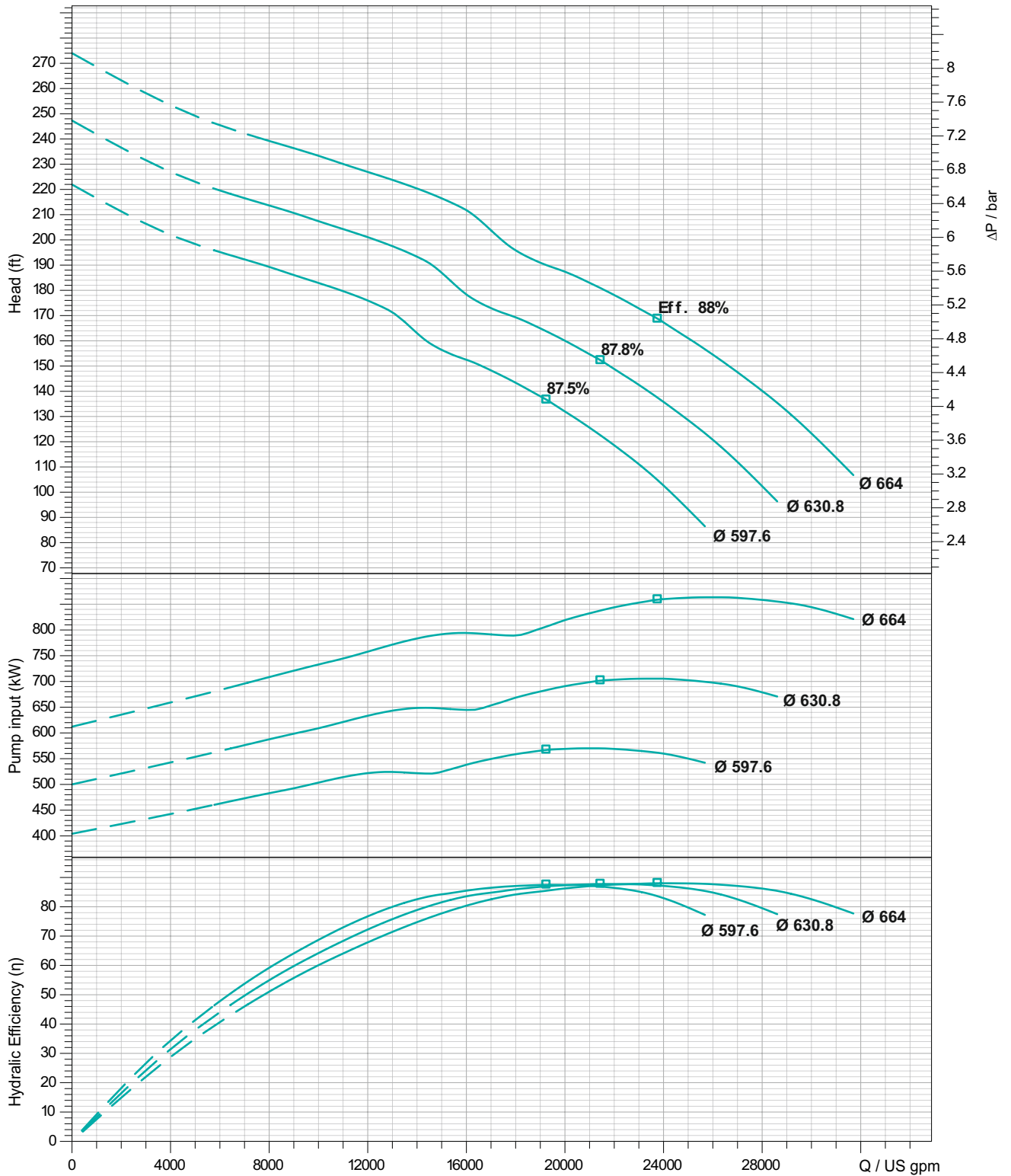

This Pump can be supplied upto max. 1 Stage.

Note: The company reserves the right to modify the technical specification and the illustrations without notice.

## Performance Curves

PUMP MODEL : **TVT-5500**

Speed : **890 rpm**

Delivery size in mm : **700mm**  
Max Impeller OD : **754mm**

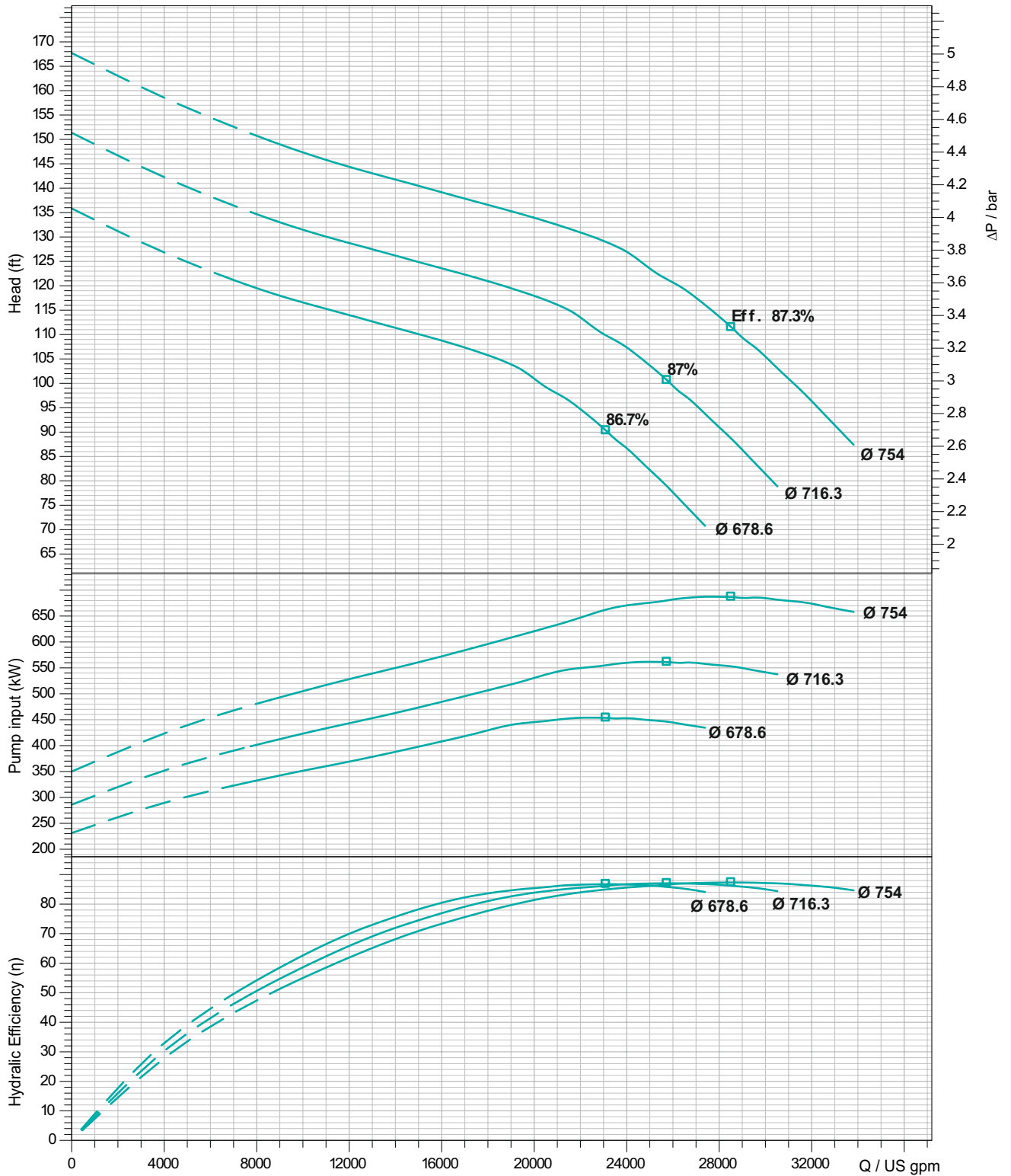

This Pump can be supplied upto max. 1 Stage.

Note: The company reserves the right to modify the technical specification and the illustrations without notice.

### Performance Curves

PUMP MODEL : **TVT-5600**

Speed : **710 rpm**

Delivery size in mm : **700mm**  
Max Impeller OD : **830mm**

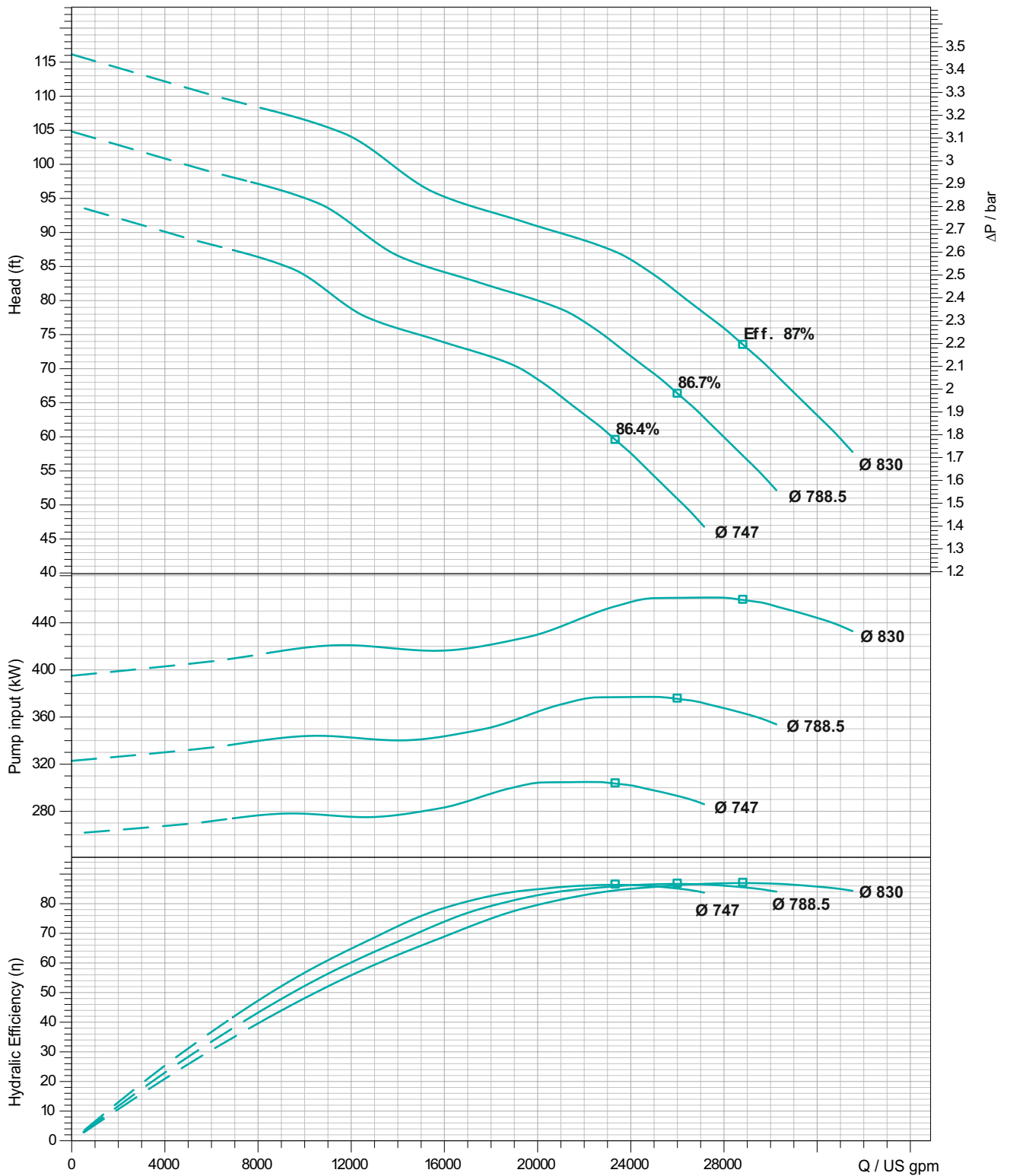

This Pump can be supplied upto max. 1 Stage.

Note: The company reserves the right to modify the technical specification and the illustrations without notice.

## Performance Curves

PUMP MODEL : **TVT-7300**

Speed : **890 rpm**

Delivery size in mm : **800mm**  
Max Impeller OD : **830mm**

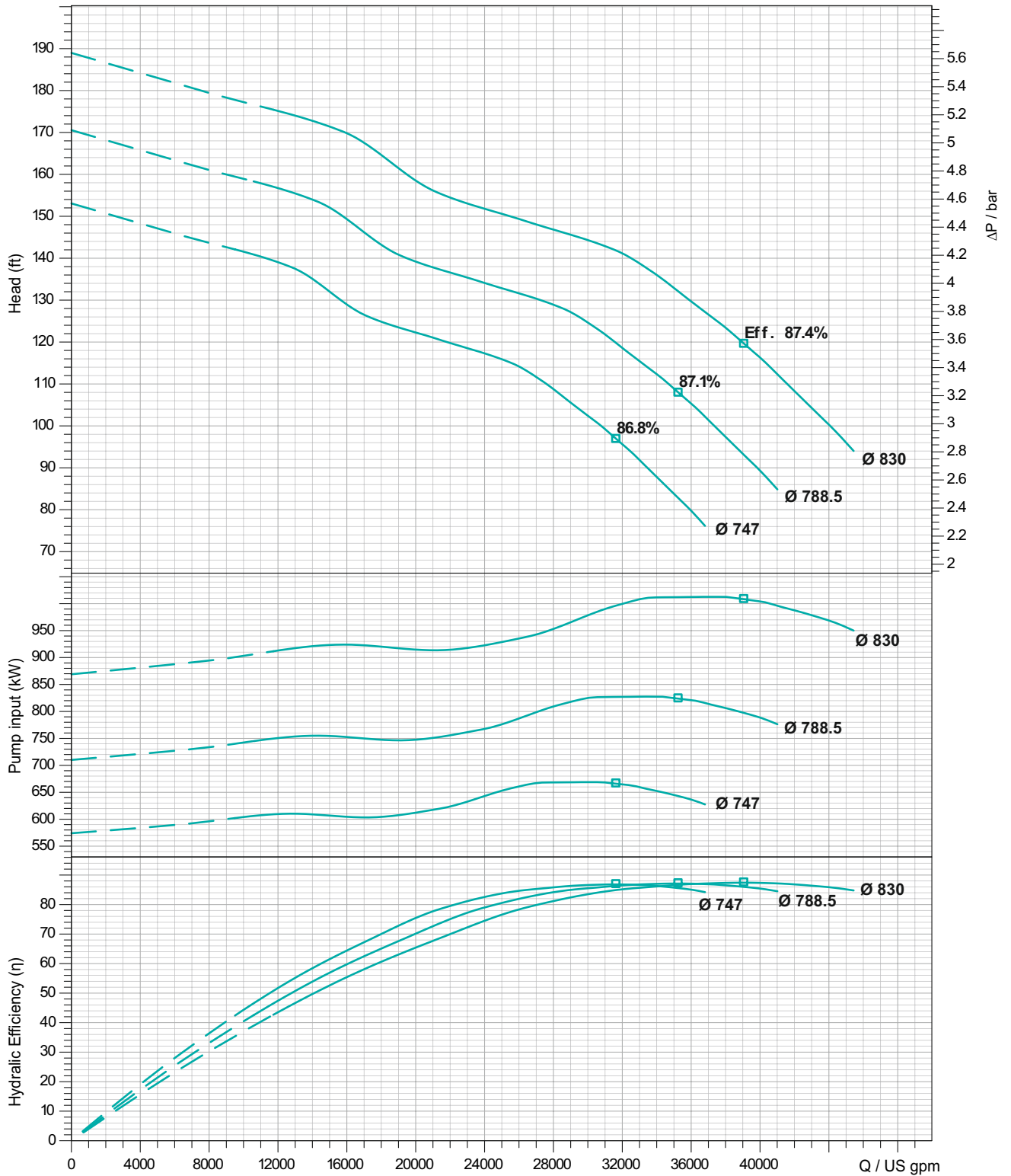

This Pump can be supplied upto max. 1 Stage.

Note: The company reserves the right to modify the technical specification and the illustrations without notice.

### Performance Curves

PUMP MODEL : **TVT-7400**

Speed : **710 rpm**

Delivery size in mm : **800mm**  
Max Impeller OD : **905mm**

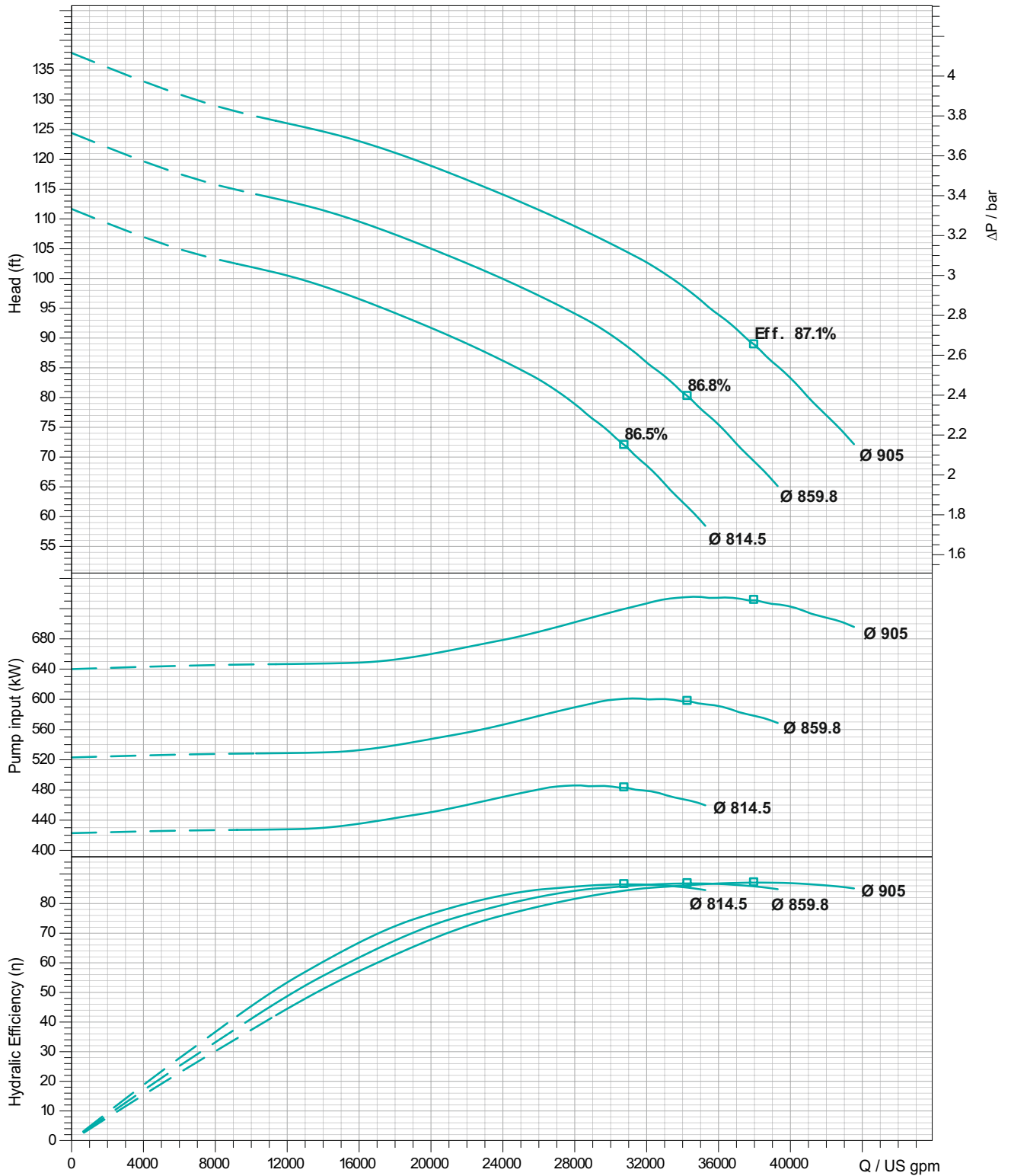

This Pump can be supplied upto max. 1 Stage.

Note: The company reserves the right to modify the technical specification and the illustrations without notice.

## Performance Curves

PUMP MODEL : **TVT-9500**

Speed : **890 rpm**

Delivery size in mm : **900mm**  
Max Impeller OD : **905mm**

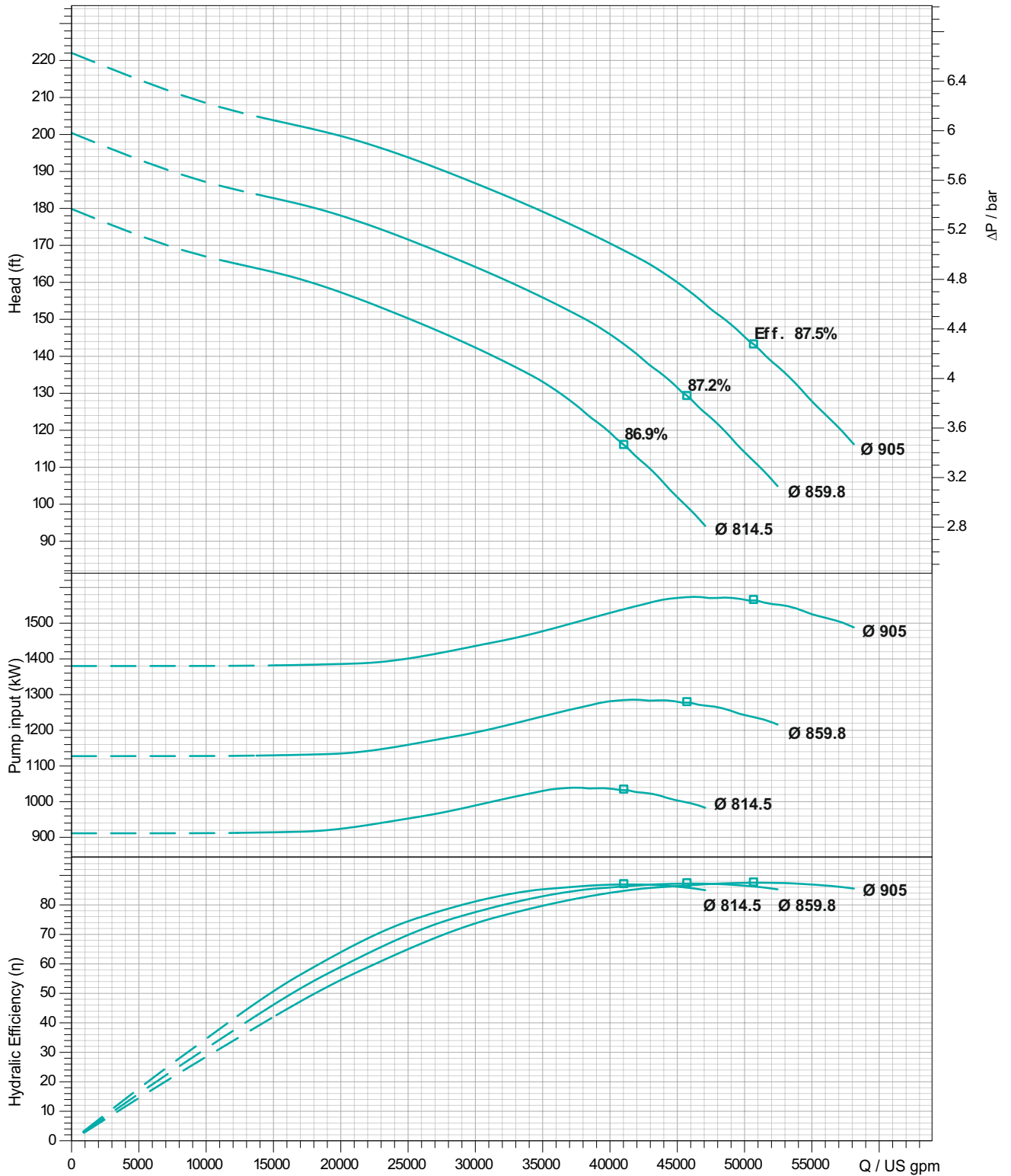

This Pump can be supplied upto max. 1 Stage.

Note: The company reserves the right to modify the technical specification and the illustrations without notice.

## GENERAL DIMENSION AND MOUNTING DETAILS - BOWL ASSEMBLY

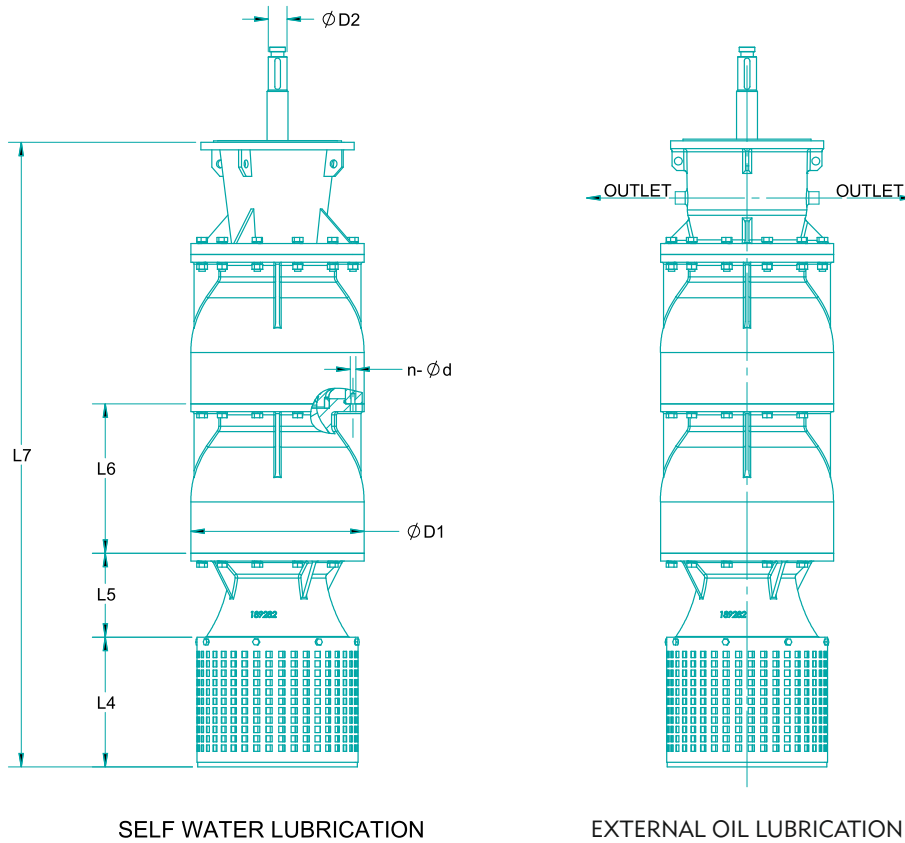

Model	L4	L5	L6	L7	D1	D2	n - $\phi d$
TVT - 115	212	108	155	688	235	35	8 - $\phi 12$
TVT - 170	209	170	175	734	282	40	12 - $\phi 14$
TVT - 270	212	160	201	782	325	45	12 - $\phi 14$
TVT - 400	213	168	230	825	340	50	12 - $\phi 14$
TVT - 500	214	185	249	920	365	55	12 - $\phi 18$
TVT - 700	320	205	276	1077	408	60	12 - $\phi 18$
TVT - 1000	355	235	418	1316	484	65	12 - $\phi 18$
TVT - 1600	400	269	478	1506	554	65	12 - $\phi 22$
TVT - 2300	431	287	476	1662	574	75	12 - $\phi 22$
TVT - 3300	479	320	533	1853	638	75	12 - $\phi 22$
TVT - 4500	602	385	672	2379	803	85	16 - $\phi 22$
TVT - 5500	638	440	756	2554	850	95	16 - $\phi 22$
TVT - 7300	698	485	830	2833	930	95	20 - $\phi 22$
TVT - 9500	818	555	970	3263	1090	100	24 - $\phi 22$

\* on request basis.

Note : All Dimensions are in mm, Unless Otherwise Specified

**CROSS SECTION VIEW WITH SOLID SHAFT MOTOR FOR EXTERNAL CLEAR WATER LUBRICATION**

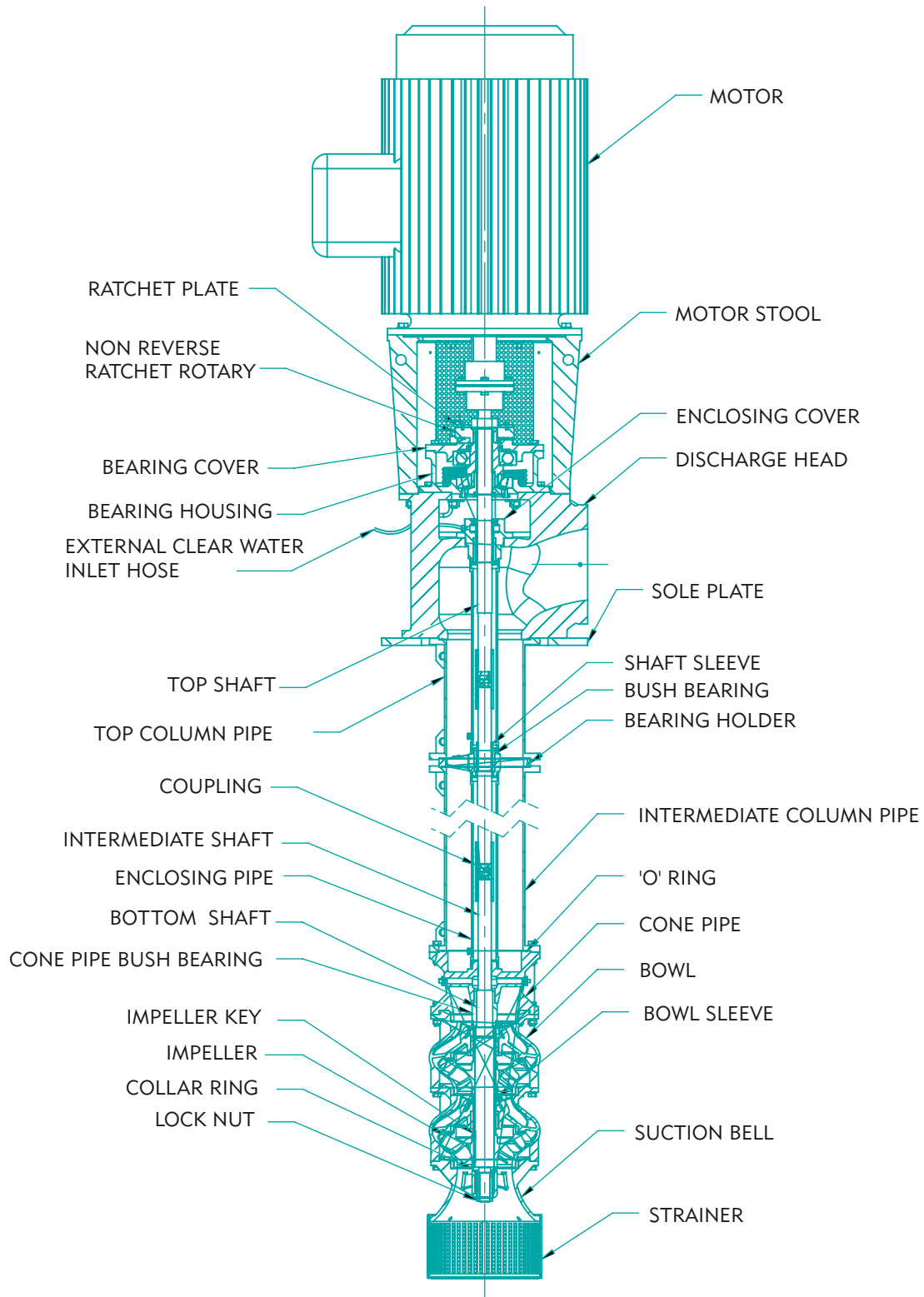

Note: The company reserves the right to modify the technical specification and the illustrations without notice.

**CROSS SECTION VIEW WITH SOLID SHAFT MOTOR FOR SELF WATER LUBRICATION**

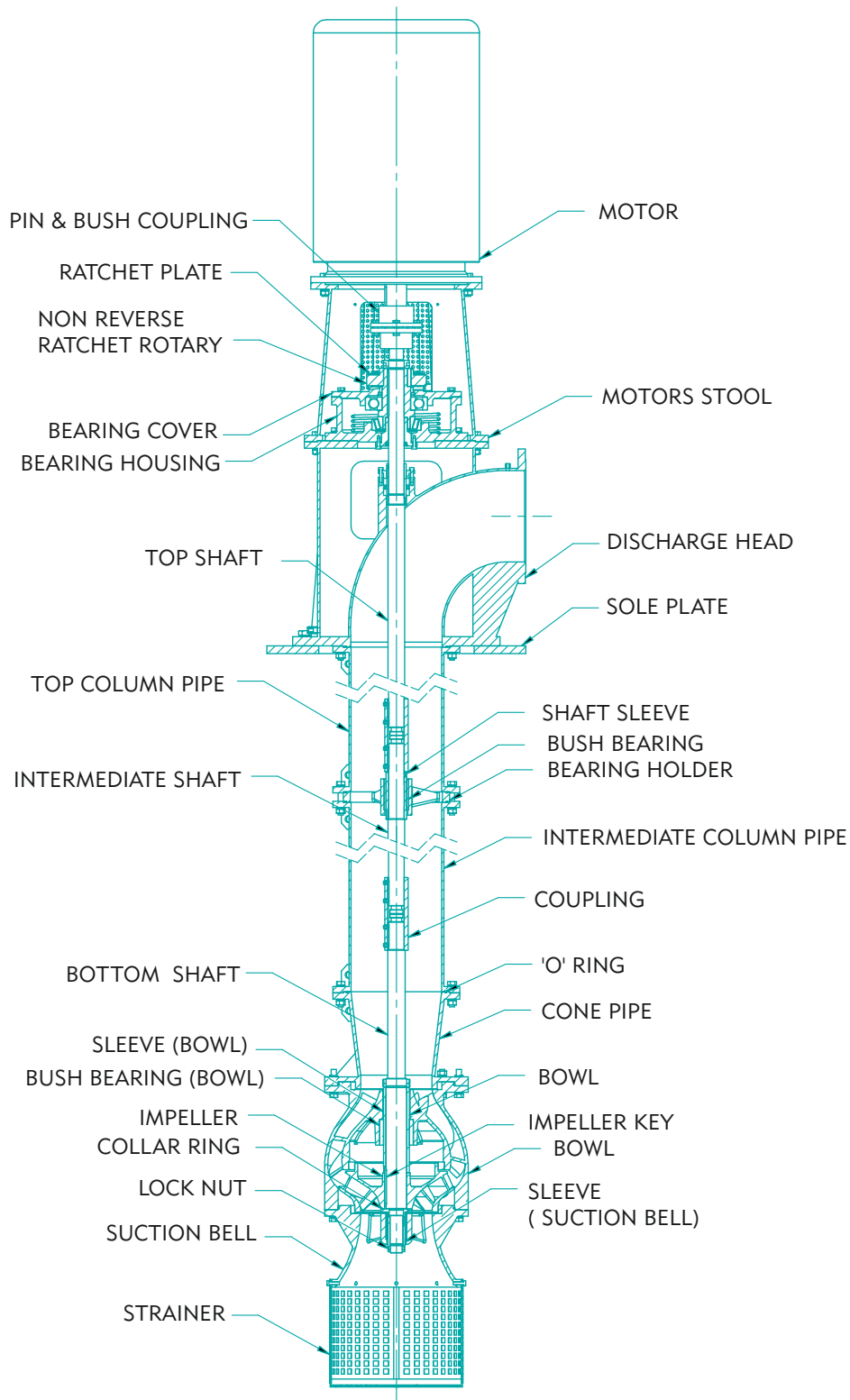

Note: The company reserves the right to modify the technical specification and the illustrations without notice.

**CROSS SECTION VIEW WITH SOLID SHAFT MOTOR FOR OIL LUBRICATION**

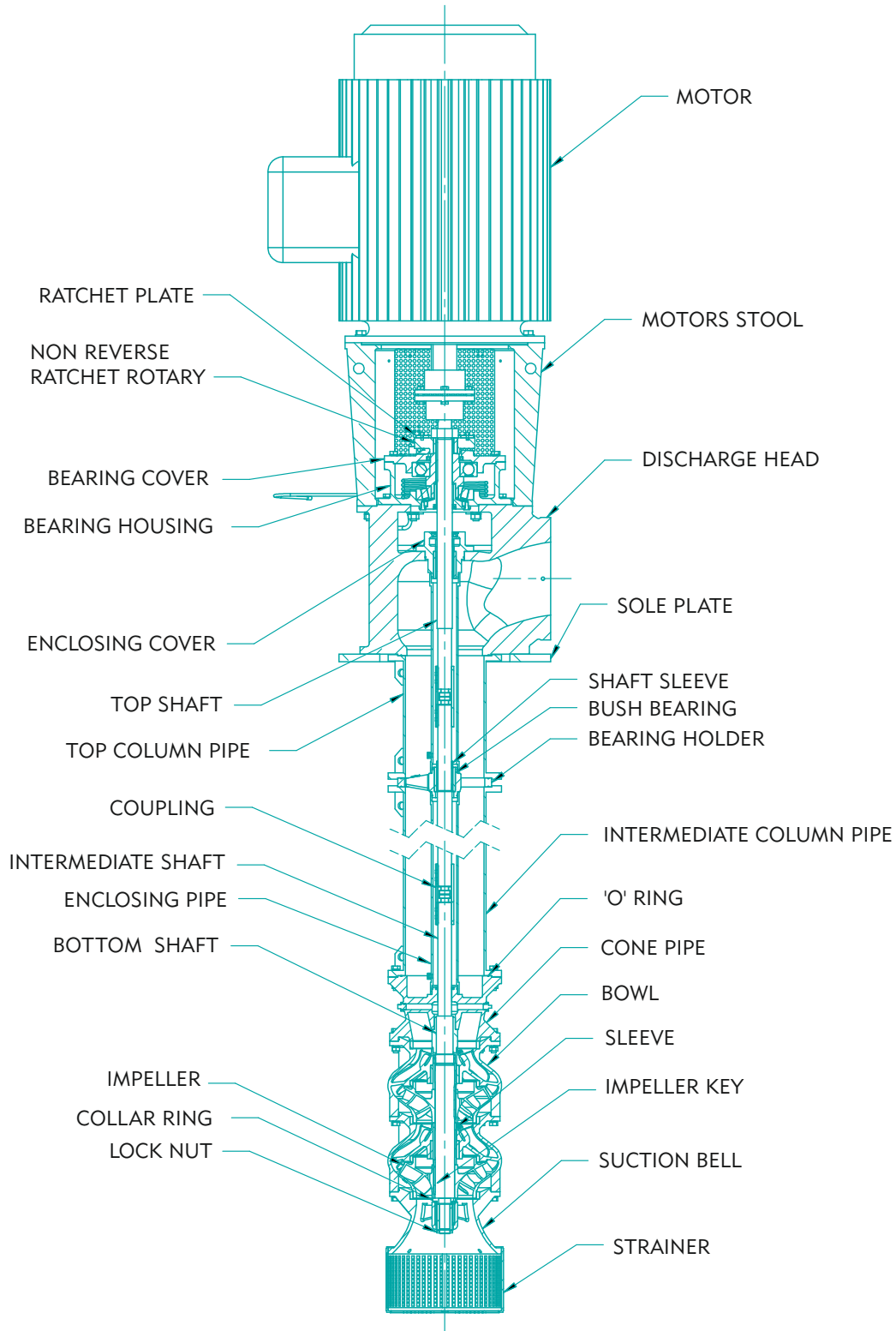

Note: The company reserves the right to modify the technical specification and the illustrations without notice.

**CROSS SECTION VIEW WITH VERTICAL HOLLOW SHAFT MOTOR FOR EXTERNAL CLEAR WATER LUBRICATION**

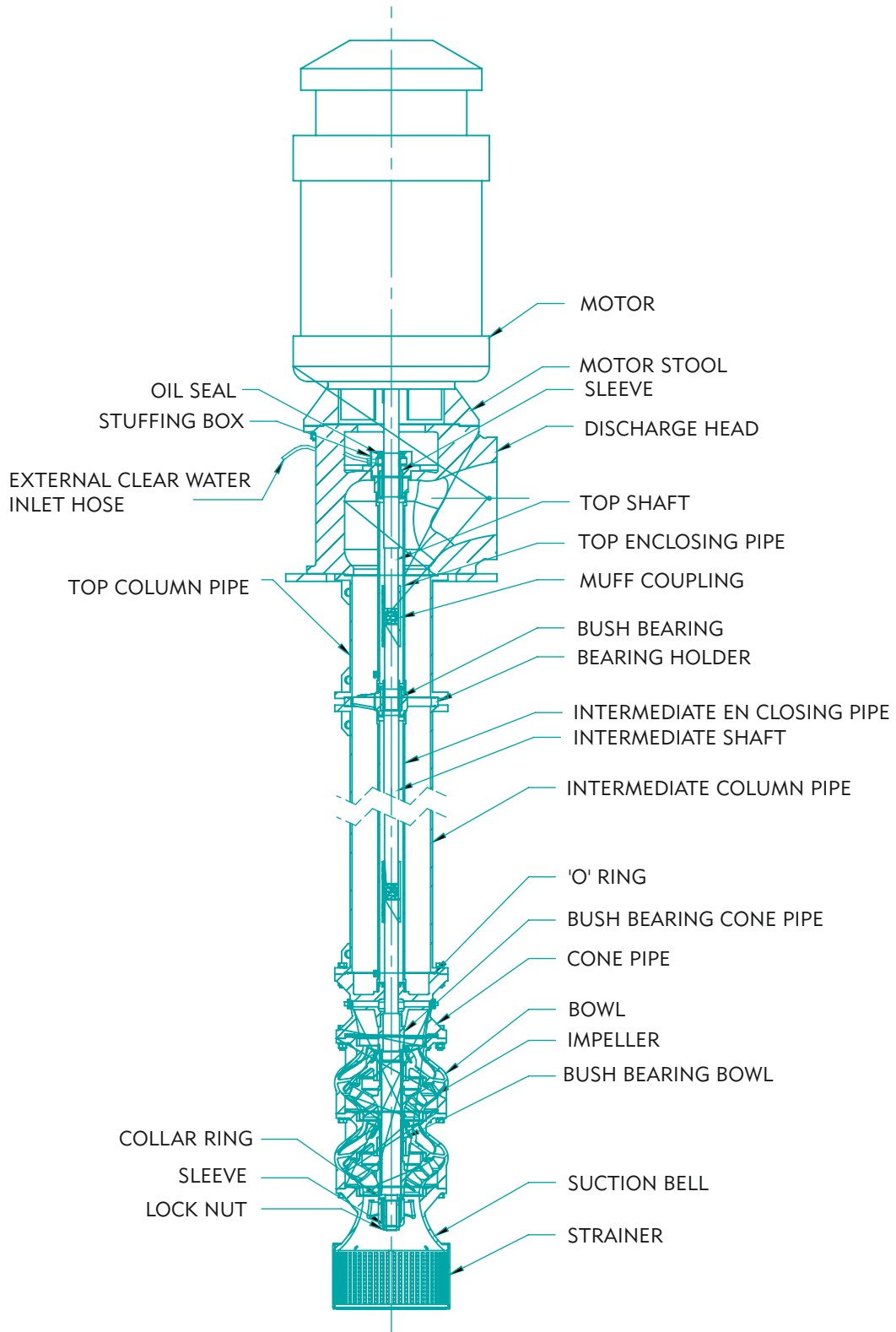

Note: The company reserves the right to modify the technical specification and the illustrations without notice.

**CROSS SECTION VIEW WITH VERTICAL HOLLOW SHAFT MOTOR FOR SELF WATER LUBRICATION**

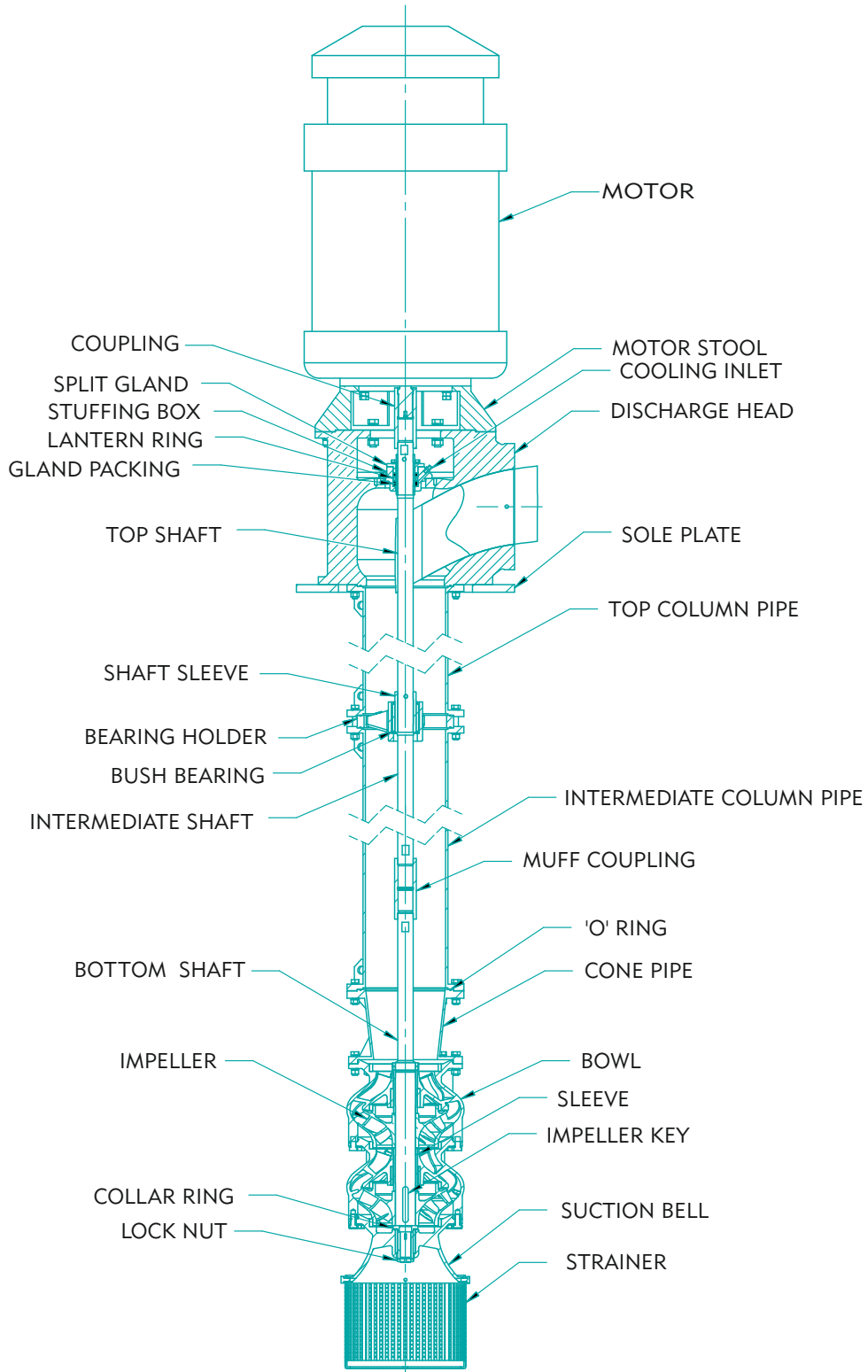

Note: The company reserves the right to modify the technical specification and the illustrations without notice.

**CROSS SECTION VIEW WITH VERTICAL HOLLOW SHAFT MOTOR FOR OIL LUBRICATION**

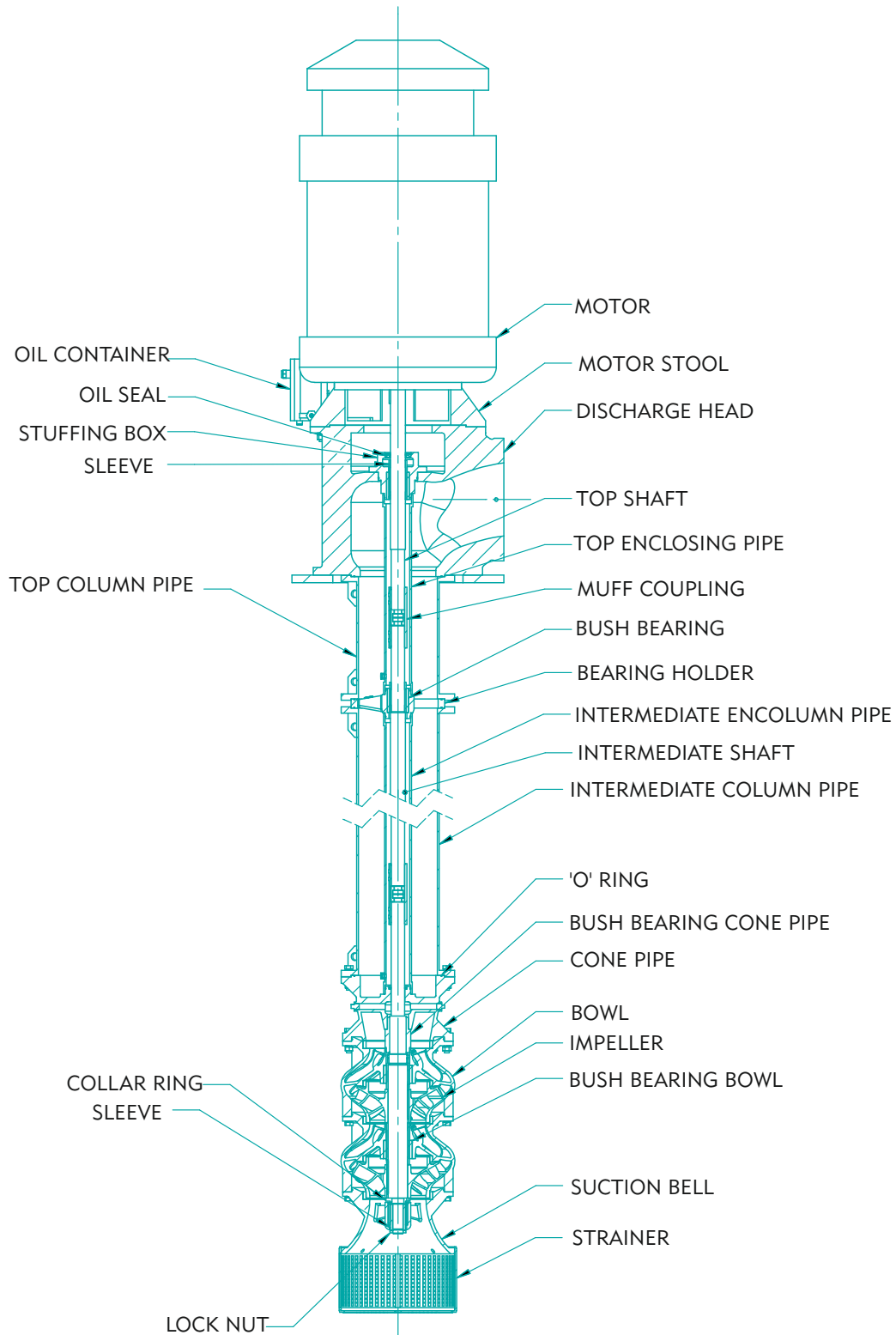

## LINE SHAFT COUPLING TYPES

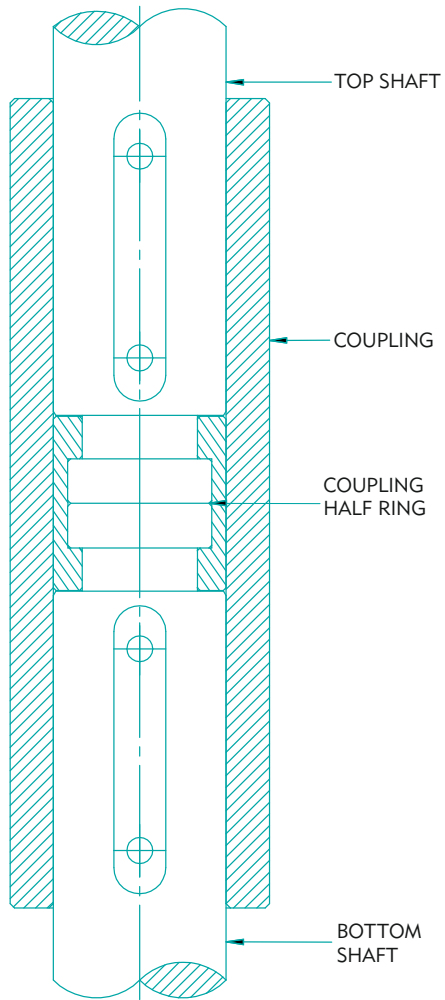

MUFF COUPLING

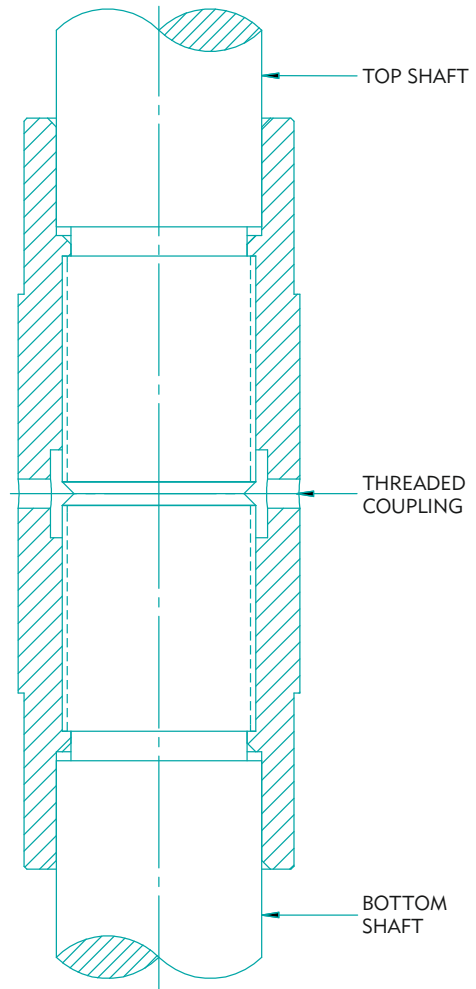

THREADED COUPLING

## THRUST BEARING WITH RATCHET ARRANGEMENT

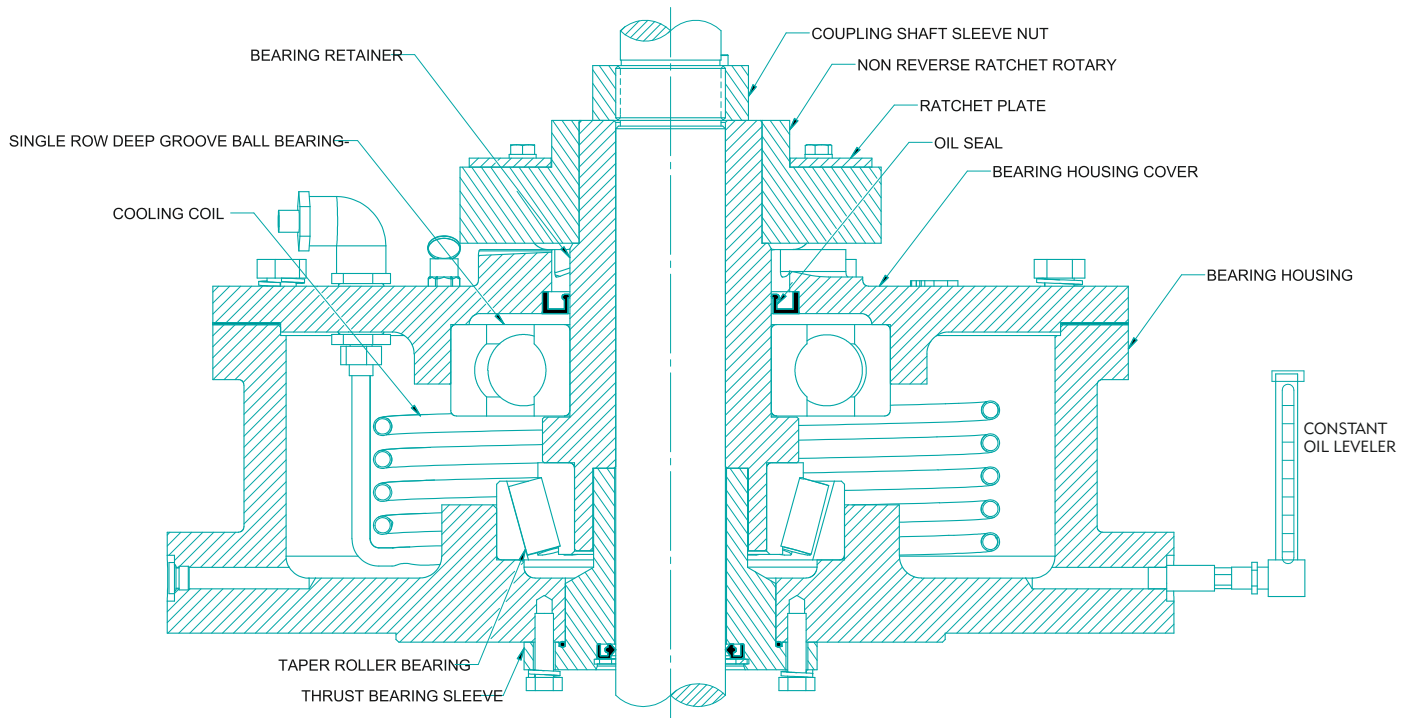

### THRUST BEARING ASSEMBLY WITH RATCHET ARRANGEMENT - ANTIFRICTION BEARING

## LUBRICATION ARRANGEMENT

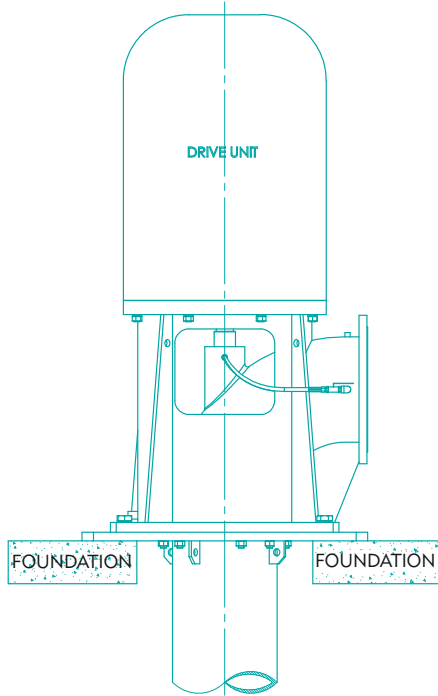

SELF WATER LUBRICATION

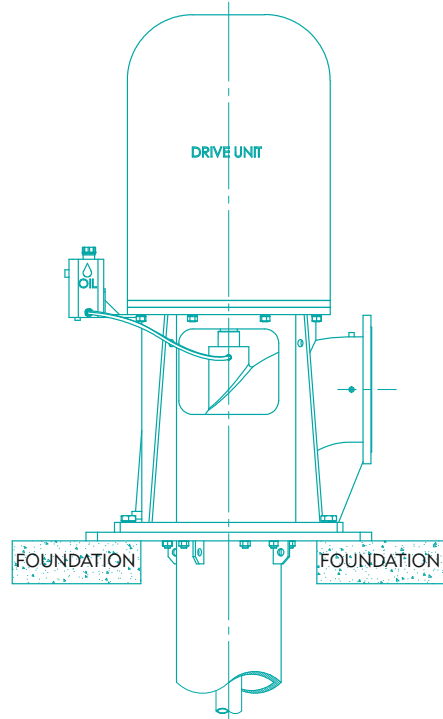

OIL LUBRICATION

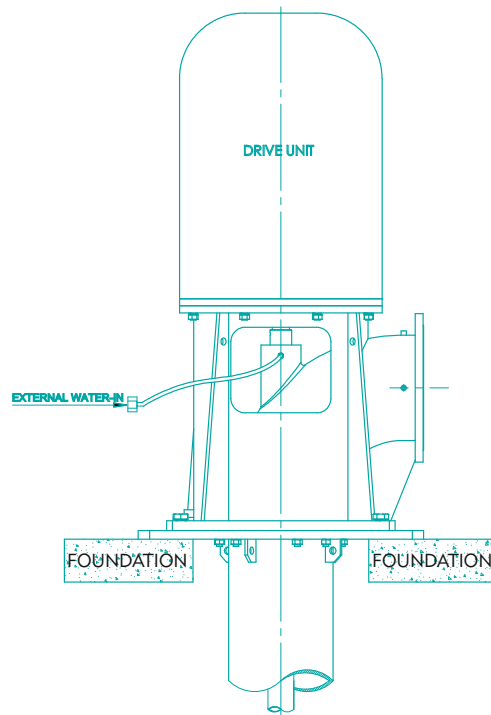

EXTERNAL CLEAR WATER LUBRICATION

Note: The company reserves the right to modify the technical specification and the illustrations without notice.

DISCHARGE HEAD WITH ABOVE GROUND LEVEL ARRANGEMENT

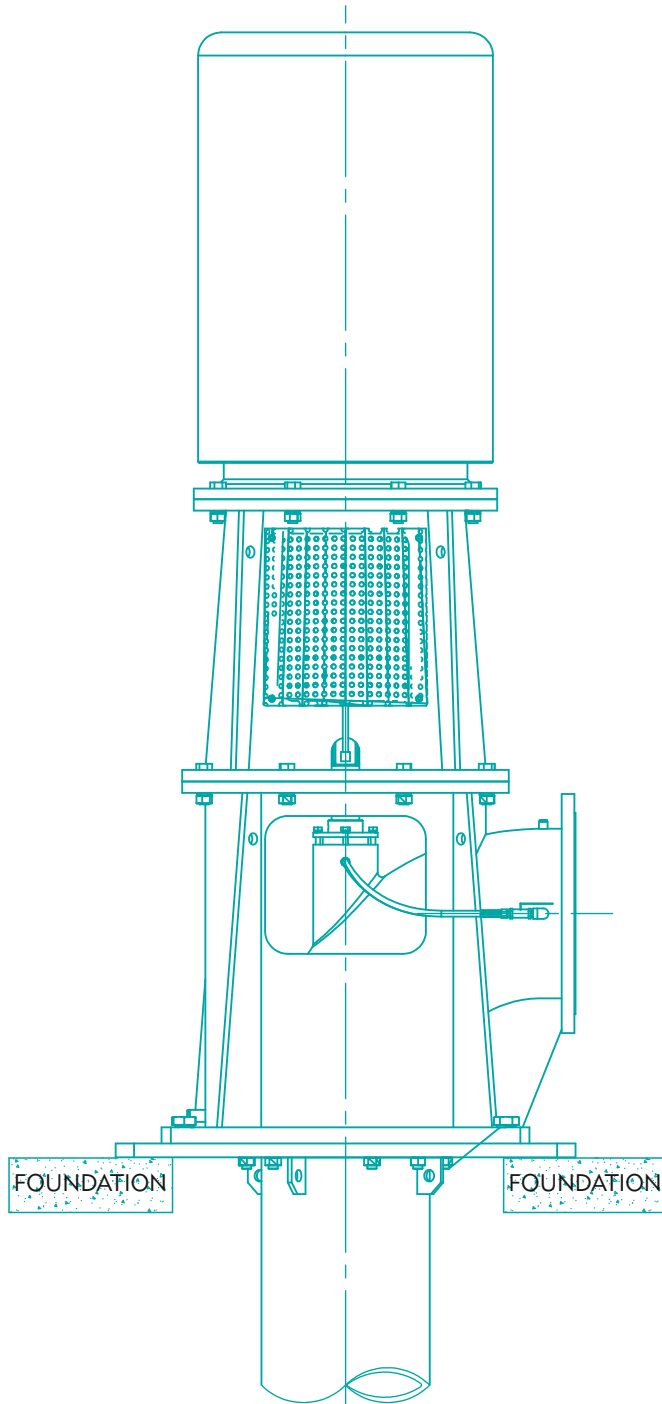

ABOVE GROUND LEVEL ARRANGEMENT  
DISCHARGE HEAD - MOTOR DRIVEN

**GENERAL ARRANGEMENT DRAWING (GAD) WITH  
SOLID SHAFT MOTOR**

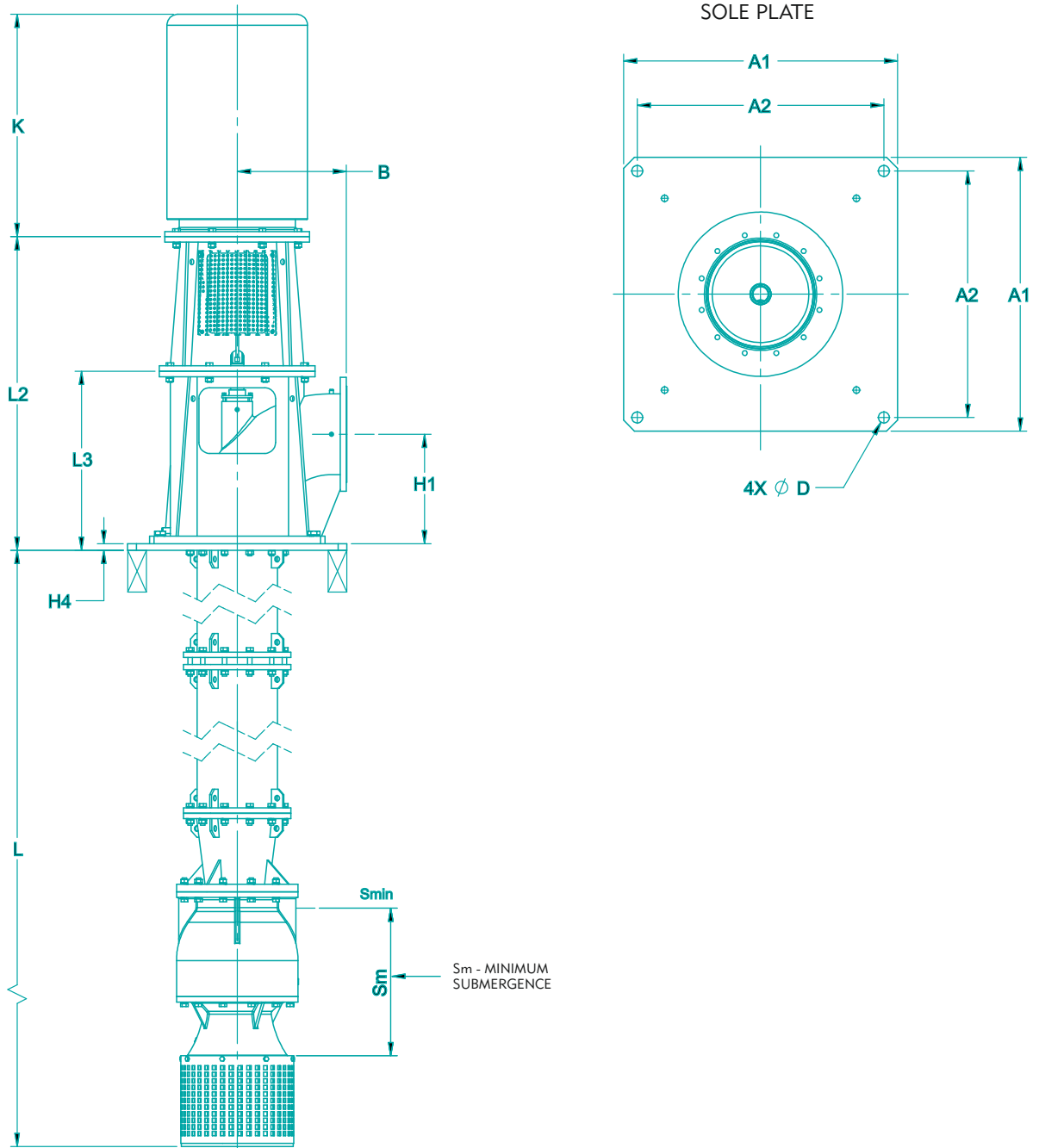

Note: The company reserves the right to modify the technical specification and the illustrations without notice.

## GENERAL DIMENSIONS & MOUNTING DETAILS FOR SOLID SHAFT MOTOR

MODEL	DN	A1	A2	n- ØD	H1	H4	B	Sm	L2	L3
TVT - 115	150	520	430	4 - 30	175	25	260	380	800	405
TVT - 170	150	520	430	4 - 30	175	25	260	485	850	405
TVT - 270	200	560	450	4 - 30	200	25	280	535	910	445
TVT - 400	200	560	450	4 - 30	200	25	280	585	940	445
TVT - 500	250	560	450	4 - 30	250	30	350	635	1165	515
TVT - 700	250	560	450	4 - 30	250	30	350	740	1165	515
TVT - 1000	300	750	650	4 - 40	300	30	375	840	1300	746
TVT - 1600	350	750	650	4 - 40	350	35	375	1040	1350	788
TVT - 2300	450	900	750	4 - 40	450	35	500	1245	1350	800
TVT - 3300	500	1300	1200	8 - 40	560	35	630	1425	1552	958
TVT - 4500	700	1700	1500	8 - 40	770	40	850	1700	2089	1420
TVT - 5500	700	1700	1500	8 - 40	770	40	850	1855	1923	1268
TVT - 7300	800	1800	1650	8 - 40	870	40	900	2085	2071	1418
TVT - 9500	900	2000	1840	8 - 40	970	40	950	2340	2610	1640

\* on request basis.

Note : All Dimensions are in mm, Unless Otherwise Specified

# GENERAL ARRANGEMENT DRAWING (GAD) WITH VERTICAL HOLLOW SHAFT MOTOR

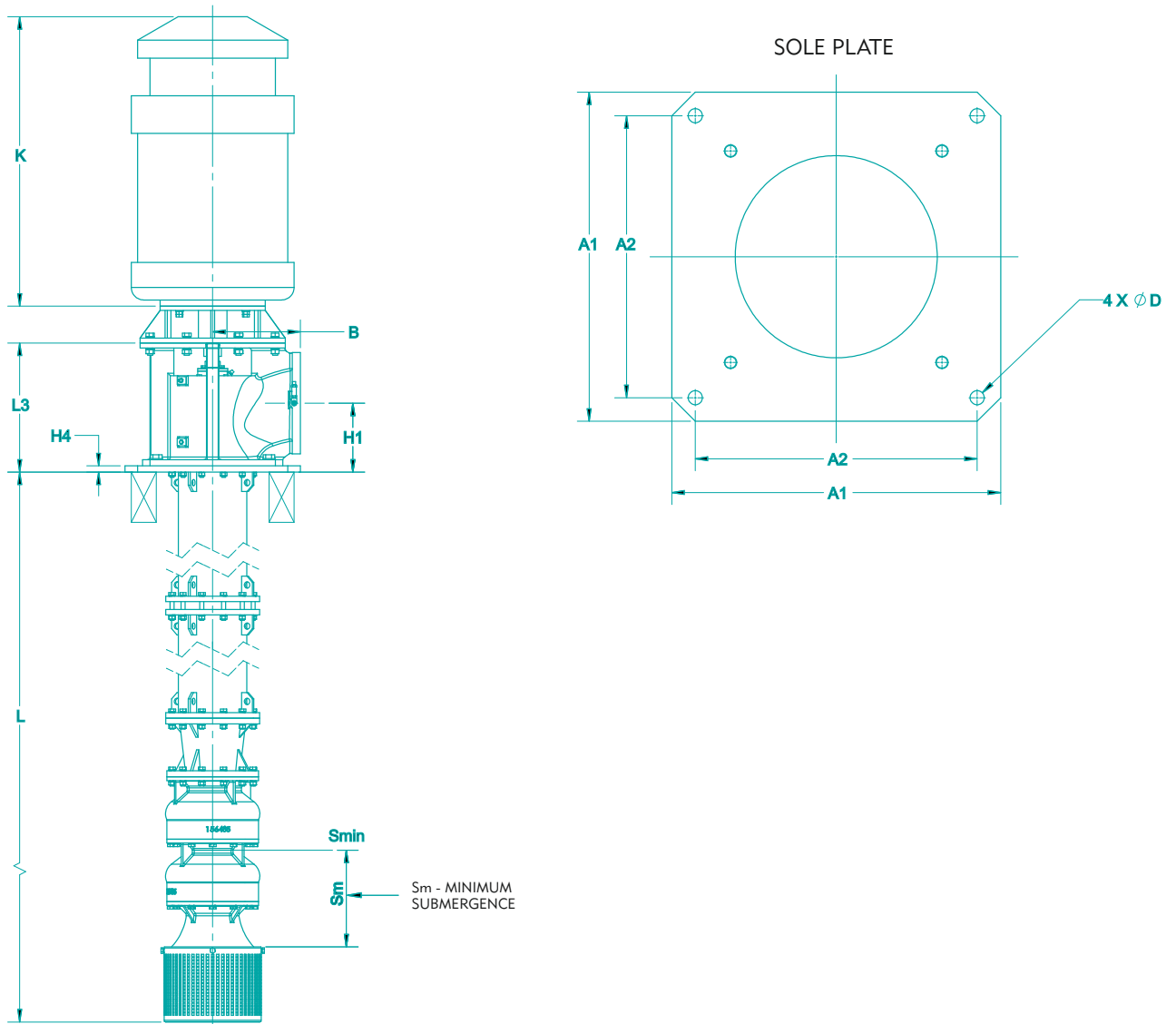

Note: The company reserves the right to modify the technical specification and the illustrations without notice.

## GENERAL DIMENSIONS & MOUNTING DETAILS FOR VERTICAL HOLLOW SHAFT MOTOR

MODEL	DN	A1	A2	n- $\phi$ D	H1	H4	B	Sm	L3
TVT - 115	150	520	430	4 - 30	175	25	260	380	405
TVT - 170	150	520	430	4 - 30	175	25	260	485	405
TVT - 270	200	560	450	4 - 30	200	25	280	535	445
TVT - 400	200	560	450	4 - 30	200	25	280	585	445
TVT - 500	250	560	450	4 - 30	250	30	350	635	515
TVT - 700	250	560	450	4 - 30	250	30	350	740	515
TVT - 1000	300	750	650	4 - 40	300	30	375	840	746
TVT - 1600	350	750	650	4 - 40	350	35	375	1040	788
TVT - 2300	450	900	750	4 - 40	450	35	500	1245	800
TVT - 3300	500	1300	1200	8 - 40	560	35	630	1425	958
TVT - 4500	700	1700	1500	8 - 40	770	40	850	1700	1420
TVT - 5500	700	1700	1500	8 - 40	770	40	850	1855	1268
TVT - 7300	800	1800	1650	8 - 40	870	40	900	2085	1418
TVT - 9500	900	2000	1840	8 - 40	970	40	950	2340	1640

\* on request basis.

Note : All Dimensions are in mm, Unless Otherwise Specified

## ENGINE DRIVEN PUMP WITH RIGHT ANGLE GEAR BOX

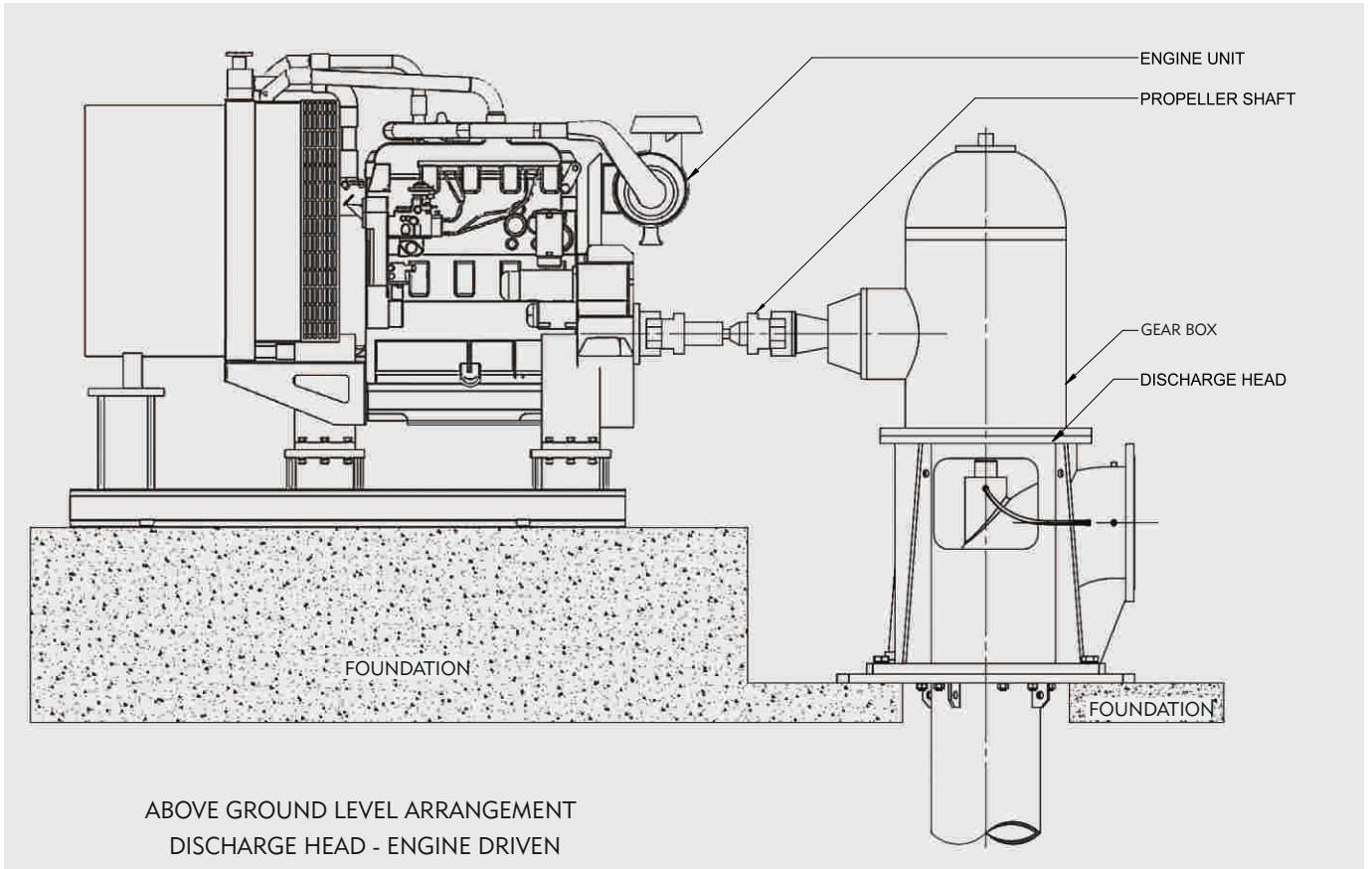





## T H E P O W E R B E H I N D T H E F O R C E

Naargo Industries Private Limited, one of the leading manufacturers of latest state of art, large range of pumps and motors, is managed by veterans who are in the pump industry for almost half a century. The products are employed in various applications like irrigation, domestic, civil construction, de-watering etc; The Company has a strong distribution network in India for sales & service and a strong global presence.

Quality is the key factor in Naargo's products. The expansive infrastructure and environment accredited with ISO 9001 quality certification, latest engineering softwares, high-tech machinery, futuristic pumping technology and high caliber workforce facilitate the production of flawless and efficient products on par with international standards under the brand name of "Tormac". The well equipped R & D wing stays alive to the changing global trends and comes out with viable solutions for innovative product development and upgradation.

The Products currently available include Stainless Steel Submersible Pumps (SS 304, SS 316 & SS 904L), Submersible Motors (CI, SS 304, SS 316 & SS 904L - HT on optional), Starters & Control Panels, Centrifugal Monoblock Pumps, End Suction Pumps, Close Coupled Pumps, Horizontal Split Case Pumps, Horizontal & Vertical Multistage Pumps, Inline Booster Systems, Sewage, Drainage & Dewatering Pumps, Induction Motors, Submersible Cables, Riser Pipes and Column Pipes.

The power, performance and endurance of the products backed by the uncompromising teamwork and value systems will certainly propel the company's growth towards new horizons in the pump industry.

IC-VTV-B/26-E2

### **Naargo Industries Private Limited,**

**REG. OFFICE :** No. 8/116, Ground Floor, Athipalayam Road, Chinnavedampatti,  
Coimbatore North - 641049, Tamil Nadu, India. Tel : +91 978 6522622,  
E-mail : [tormac@tormacpumps.com](mailto:tormac@tormacpumps.com), Web : [www.tormacpumps.com](http://www.tormacpumps.com)

**Tormac**  
P U M P S